

Design and Construction of Large, Welded, Low-Pressure Storage Tanks

API STANDARD 620
TENTH EDITION, FEBRUARY 2002

ADDENDUM 1, JUNE 2004

For Committee
Use Only



American
Petroleum
Institute

**Helping You
Get The Job
Done Right.SM**

**For Committee
Use Only**

Design and Construction of Large, Welded, Low-Pressure Storage Tanks

Downstream Segment

API STANDARD 620
TENTH EDITION, FEBRUARY 2002

ADDENDUM 1, JUNE 2004



American
Petroleum
Institute

**Helping You
Get The Job
Done Right.SM**

SPECIAL NOTES

API publications necessarily address problems of a general nature. With respect to particular circumstances, local, state, and federal laws and regulations should be reviewed.

API is not undertaking to meet the duties of employers, manufacturers, or suppliers to warn and properly train and equip their employees, and others exposed, concerning health and safety risks and precautions, nor undertaking their obligations under local, state, or federal laws.

Information concerning safety and health risks and proper precautions with respect to particular materials and conditions should be obtained from the employer, the manufacturer or supplier of that material, or the material safety data sheet.

Nothing contained in any API publication is to be construed as granting any right, by implication or otherwise, for the manufacture, sale, or use of any method, apparatus, or product covered by letters patent. Neither should anything contained in the publication be construed as insuring anyone against liability for infringement of letters patent.

Generally, API standards are reviewed and revised, reaffirmed, or withdrawn at least every five years. Sometimes a one-time extension of up to two years will be added to this review cycle. This publication will no longer be in effect five years after its publication date as an operative API standard or, where an extension has been granted, upon republication. Status of the publication can be ascertained from the API Standards department telephone (202) 682-8000. A catalog of API publications, programs and services is published annually and updated biannually by API, and available through Global Engineering Documents, 15 Inverness Way East, M/S C303B, Englewood, CO 80112-5776.

04 |

This document was produced under API standardization procedures that ensure appropriate notification and participation in the developmental process and is designated as an API standard. Questions concerning the interpretation of the content of this standard or comments and questions concerning the procedures under which this standard was developed should be directed in writing to the Director of the Standards department, American Petroleum Institute, 1220 L Street, N.W., Washington, D.C. 20005. Requests for permission to reproduce or translate all or any part of the material published herein should be addressed to the Director, Business Services.

04 |

04 |

API standards are published to facilitate the broad availability of proven, sound engineering and operating practices. These standards are not intended to obviate the need for applying sound engineering judgment regarding when and where these standards should be utilized. The formulation and publication of API standards is not intended in any way to inhibit anyone from using any other practices.

Any manufacturer marking equipment or materials in conformance with the marking requirements of an API standard is solely responsible for complying with all the applicable requirements of that standard. API does not represent, warrant, or guarantee that such products do in fact conform to the applicable API standard.

All rights reserved. No part of this work may be reproduced, stored in a retrieval system, or transmitted by any means, electronic, mechanical, photocopying, recording, or otherwise, without prior written permission from the publisher. Contact the Publisher, API Publishing Services, 1220 L Street, N.W., Washington, D.C. 20005.

04 |

NOTICE

INSTRUCTIONS FOR SUBMITTING A PROPOSED REVISION TO THIS STANDARD UNDER CONTINUOUS MAINTENANCE

04

This standard is maintained under continuous maintenance procedures by the American Petroleum Institute for which the Standards Department. These procedures establish a documented program for regular publication of addenda or revisions, including timely and documented consensus action on requests for revisions to any part of the standard. Proposed revisions shall be submitted to the Director, Standards Department, American Petroleum Institute, 1220 L Street, NW, Washington, D.C. 20005-4070, standards@api.org.

For Committee
Use Only

FOREWORD

This standard is based on the accumulated knowledge and experience of purchasers and manufacturers of welded, low-pressure oil storage tanks of various sizes and capacities for internal pressures not more than 15 pounds per square inch gauge. The object of this publication is to provide a purchase specification to facilitate the manufacture and procurement of such storage tanks.

If tanks are purchased in accordance with the specifications of this standard, the purchaser is required to specify certain basic requirements. The purchaser may desire to modify, delete, or amplify sections of this standard, but reference shall not be made to this standard on the nameplate or manufacturer's certification for tanks that do not fulfill the minimum requirements or that exceed the limitations of this standard. It is strongly recommended that such modifications, deletions, or amplifications be made by supplementing this standard, rather than by rewriting or incorporating sections of it into another complete standard.

Each edition, revision, or addenda to this API standard may be used beginning with the date of issuance shown on the cover page for that edition, revision, or addenda. Each edition, revision, or addenda to this API standard becomes effective six months after the date of issuance for equipment that is certified by the manufacturer as being designed, fabricated, constructed, examined, and tested per this standard. During the six-month time between the date of issuance of the edition, revision, or addenda and the effective date, the purchaser and manufacturer shall specify to which edition, revision, or addenda the equipment is to be built.

The design rules given in this standard are minimum requirements. More stringent design rules specified by the purchaser or furnished by the manufacturer are acceptable when mutually agreed upon by the purchaser and the manufacturer. This standard is not to be interpreted as approving, recommending, or endorsing any specific design, nor as limiting the method of design or construction.

This standard is not intended to cover storage tanks that are to be erected in areas subject to regulations more stringent than the specifications of this standard. When this standard is specified for such tanks, it should be followed insofar as it does not conflict with local requirements.

After revisions to this standard have been issued, they may be applied to tanks to be completed after the date of issue. The tank nameplate shall state the date of the edition and any revision to that edition to which the tank is designed and constructed.

API publications may be used by anyone desiring to do so. Every effort has been made by the Institute to assure the accuracy and reliability of the data contained in them; however, the Institute makes no representation, warranty, or guarantee in connection with this publication and hereby expressly disclaims any liability or responsibility for loss or damage resulting from its use or for the violation of any federal, state, or municipal regulation with which this publication may conflict.

Suggested revisions are invited and should be submitted to the standardization manager, American Petroleum Institute, 1220 L Street, N.W., Washington, D.C. 20005.

CONTENTS

		Page	
1	SCOPE	1-1	
	1.1 General	1-1	
	1.2 Coverage	1-1	
	1.3 Limitations	1-2	04
2	REFERENCES	2-1	
3	DEFINITIONS	3-1	
	3.1 Stress and Pressure Terms	3-1	04
	3.2 Capacity Terms	3-1	
	3.3 Tank Wall	3-1	
	3.4 Welding Terms	3-1	04
4	MATERIALS	4-1	
	4.1 General	4-1	
	4.2 Plates	4-1	04
	4.3 Pipe, Flanges, Forging, and Castings	4-5	
	4.4 Bolting Material	4-6	
	4.5 Structural Shapes	4-6	04
5	DESIGN	5-1	
	5.1 General	5-1	02
	5.2 Operating Temperature	5-1	
	5.3 Pressures Used In Design	5-1	04
	5.4 Loadings	5-2	
	5.5 Maximum Allowable Stress for Walls	5-2	04
	5.6 Maximum Allowable Stress Values for Structural Members and Bolts	5-8	
	5.7 Corrosion Allowance	5-8	
	5.8 Linings	5-8	
	5.9 Procedure for Designing Tank Walls	5-10	
	5.10 Design of Sidewalls, Roofs, and Bottoms	5-11	04
	5.11 Special Considerations Applicable to Bottoms That Rest Directly on Foundations	5-18	
	5.12 Design Of Roof And Bottom Knuckle Regions and Compression-ring Girders	5-20	
	5.13 Design Of Internal And External Structural Members	5-24	
	5.14 Shapes, Locations, and Maximum Sizes of Wall Openings	5-26	
	5.15 Inspection Openings	5-27	
	5.16 Reinforcement of Single Openings	5-27	
	5.17 Reinforcement of Multiple Openings	5-35	
	5.18 Design of Large, Centrally Located, Circular Openings in Roofs and Bottoms	5-36	
	5.19 Nozzle Necks and Their Attachments to the Tank	5-37	
	5.20 Bolted Flanged Connections	5-38	
	5.21 Cover Plates	5-38	04
	5.22 Permitted Types of Joints	5-42	
	5.23 Welded Joint Efficiency	5-42	
	5.24 Plug Welds and Slot Welds	5-43	
	5.25 Stress Relieving	5-43	
	5.26 Radiographic/Ultrasonic Examination	5-44	04
	5.27 Flush-Type Shell Connection	5-44	02
6	FABRICATION	6-1	
	6.1 General	6-1	
	6.2 Workmanship	6-1	
	6.3 Cutting Plates	6-1	
	6.4 Forming Sidewall Sections and Roof and Bottom Plates	6-1	04

	Page	
6.5	Dimensional Tolerances	6-1
6.6	Details of Welding	6-2
6.7	Qualification of Welding Procedure	6-2
6.8	Qualification of Welders	6-3
6.9	Matching Plates	6-3
6.10	Cleaning Surfaces to be Welded	6-3
6.11	Weather Conditions for Welding	6-4
6.12	Reinforcement on Welds	6-4
6.13	Merging Weld With Plate Surface	6-4
6.14	Aligning of Main Joints	6-4
6.15	Repairing Defects in Welds	6-4
6.16	Matching Plates of Unequal Thickness	6-4
6.17	Fitting Up of Closure Plates	6-4
6.18	Thermal Stress Relief	6-4
6.19	Peening Field Welds	6-5
7	INSPECTION, EXAMINATION AND TESTING	7-1
7.1	Responsibility of Examiner	7-1
7.2	Qualifications of Examiners	7-1
7.3	Access for Inspector	7-1
7.4	Facilities for Inspector	7-1
7.5	Approval of Repairs	7-1
7.6	Inspection of Materials	7-1
7.7	Stamping of Plates	7-1
7.8	Measuring Thickness of Material	7-1
7.9	Inspection of Surfaces Exposed During Fabrication	7-1
7.10	Surface Inspection of Component Parts	7-2
7.11	Check of Dimensions of Component Parts	7-2
7.12	Check of Chemical and Physical Property Data	7-2
7.13	Data Required From Manufacturer on Completed Tanks	7-2
7.14	Check of Stress-Relieving Operation	7-2
7.15	Examination Method and Acceptance Criteria	7-2
7.16	Inspection of Weld	7-4
7.17	Radiographic/Ultrasonic Examination Requirements	7-5
7.18	Standard Hydrostatic and Pneumatic Tests	7-6
7.19	Proof Tests for Establishing Allowable Working Pressures	7-8
7.20	Test Gauges	7-9
8	MARKING	8-1
8.1	Nameplates	8-1
8.2	Division of Responsibility	8-1
8.3	Manufacturer's Report and Certificate	8-1
8.4	Multiple Assemblies	8-1
9	PRESSURE- AND VACUUM-RELIEVING DEVICES	9-1
9.1	Scope	9-1
9.2	Pressure Limits	9-1
9.3	Construction of Devices	9-1
9.4	Means of Venting	9-1
9.5	Liquid Relief Valves	9-1
9.6	Marking	9-1
9.7	Pressure Setting of Safety Devices	9-2
APPENDIX A	TECHNICAL INQUIRY RESPONSES	A-1
APPENDIX B	USE OF MATERIALS THAT ARE NOT IDENTIFIED WITH LISTED SPECIFICATIONS	B-1
APPENDIX C	SUGGESTED PRACTICE REGARDING FOUNDATIONS	C-1

	Page	
APPENDIX D	SUGGESTED PRACTICE REGARDING SUPPORTING STRUCTURES	D-1
APPENDIX E	SUGGESTED PRACTICE REGARDING ATTACHED STRUCTURES (INTERNAL AND EXTERNAL)	E-1
APPENDIX F	EXAMPLES ILLUSTRATING APPLICATION OF RULES TO VARIOUS DESIGN PROBLEMS	F-1
APPENDIX G	CONSIDERATIONS REGARDING CORROSION ALLOWANCE AND HYDROGEN-INDUCED CRACKING	G-1
APPENDIX H	RECOMMENDED PRACTICE FOR USE OF PREHEAT, POST-HEAT, AND STRESS RELIEF	H-1
APPENDIX I	SUGGESTED PRACTICE FOR PEENING	I-1
APPENDIX J	(RESERVED FOR FUTURE USE)	J-1
APPENDIX K	SUGGESTED PRACTICE FOR DETERMINING THE RELIEVING CAPACITY REQUIRED	K-1
APPENDIX L	SEISMIC DESIGN OF STORAGE TANKS.	L-1
APPENDIX M	RECOMMENDED SCOPE OF THE MANUFACTURER'S REPORT	M-1
APPENDIX N	INSTALLATION OF PRESSURE-RELIEVING DEVICES	N-1
APPENDIX O	SUGGESTED PRACTICE REGARDING INSTALLATION OF LOW-PRESSURE STORAGE TANKS	O-1
APPENDIX P	NDE AND TESTING REQUIREMENTS SUMMARY	P-1
APPENDIX Q	LOW-PRESSURE STORAGE TANKS FOR LIQUEFIED HYDROCARBON GASES	Q-1
APPENDIX R	LOW-PRESSURE STORAGE TANKS FOR REFRIGERATED PRODUCTS	R-1
APPENDIX S	AUSTENITIC STAINLESS STEEL STORAGE TANKS.	S-1
APPENDIX U	ULTRASONIC EXAMINATION IN LIEU OF RADIOGRAPHY.	U-1

Figures

4-1	Isothermal Lines Showing 1-Day Mean Ambient Temperature	4-2
4-2	Minimum Permissible Design Metal Temperature for Pipe, Flanges, and Forgings without Impact Testing	4-7
4-3	Governing Thickness for Impact Test Determination of Pipe, Flanges, and Forgings.	4-8
5-1	Biaxial Stress Chart for Combined Tension and Compression, 30,000–38,000 lbf/in. ² Yield Strength Steels	5-3
5-2	Method for Preparing Lap-Welded Bottom Plates Under the Tank Sidewall	5-12
5-3	Detail of Double Fillet-Groove Weld for Bottom Plates with a Nominal Thickness Greater than 1/2 in.	5-12
5-4	Typical Free-Body Diagrams for Certain Shapes of Tanks	5-14
5-5	Compression-Ring Region.	5-22
5-6	Permissible and Nonpermissible Details of Construction for a Compression-Ring Juncture.	5-23
5-7	Reinforcement of Single Openings	5-28
5-8	Part 1—Acceptable Types of Welded Nozzles and Other Connections	5-30
5-8	Part 2—Acceptable Types of Welded Nozzles and Other Connections	5-31
5-8	Part 3—Acceptable Types of Welded Nozzles and Other Connections	5-32
5-8	Part 4—Acceptable Types of Welded Nozzles and Other Connections	5-33
5-9	Large Head Openings and Conical Shell-Reducer Sections.	5-36
5-10	Acceptable Types of Flat Heads and Covers.	5-39
5-11	Spherically Dished Steel Plate Covers with Bolting Flanges	5-41
5-12	Part 1—Flush-Type Sidewall Connection.	5-46
5-12	Part 2—Flush-Type Sidewall Connection.	5-47
5-13	Design Factors for Flush-Type Connections	5-48
5-14	Rotation of Sidewall Connection.	5-49
6-1	Butt Welding of Plates of Unequal Thickness.	6-5
8-1	Nameplate	8-2
F-1	Reduction of Design Stresses Required to Allow for Biaxial Stress of the Opposite Sign . . .	F-2

	Page	
F-2	Examples Illustrating the Use of a Biaxial Stress Chart for Combined Tension and Compression, 30,000–38,000 Pounds per Square Inch Yield Strength Steels	F-5
F-3	Form for Use in Graphical Solutions of Problems Involving Biaxial Tension and Compression, 30,000–38,000 Pounds per Square Inch Yield Strength Steels	F-6
F-4	Free-Body Sketch.	F-8
F-5	Example of a Reinforced Opening	F-13
F-6	Example of a Reinforced Opening	F-15
F-7	Example of a Reinforced Opening	F-18
F-8	Example of a Reinforced Opening	F-19
L-1	Seismic Zone Map	L-3
L-1	Part 2—Seismic Zone Map	L-4
L-2	Curves for Obtaining Factors W_1/W_T and W_2/W_T for the Ratio D/H	L-5
L-3	Curves for Obtaining Factors X_1/H and X_2/H for the Ratio D/H	L-5
L-4	Curve for Obtaining Factor k for the Ratio D/H	L-5
L-5	Curve for Obtaining the Value of b when $M/[D_2(w_t+w_L)]$ Exceeds 0.785	L-7
Q-1	Typical Stiffening-Ring Weld Details	Q-9
Q-2	Radiographic/Ultrasonic Requirements for Butt-Welded Shell Joints in Cylindrical Flat-Bottom Tanks	Q-14
R-1	Typical Stiffening-Ring Weld Details	R-5
R-2	Radiographic/Ultrasonic Examination Requirements for Butt-Welded Shell Joints in Cylindrical Flat-Bottom Tanks	R-11
 Tables		
4-1	Minimum Requirements for Plate Specifications to be Used for Design Metal Temperatures	4-3
4-2	Maximum Permissible Alloy Content	4-4
5-1	Maximum Allowable Stress Values for Simple Tension	5-4
5-2	Maximum Allowable Efficiencies for Arc-Welded Joints	5-7
5-3	Maximum Allowable Stress Values for Structural Members	5-9
5-4	Sidewall-to-Bottom Fillet Weld for Flat-Bottom Cylindrical Tanks	5-12
5-5	Factors for Determining Values of R_1 and R_2 for Ellipsoidal Roofs and Bottoms	5-15
5-6	Tank Radius Versus Nominal Plate Thickness	5-18
5-7	Allowable Tension Stresses for Uplift Pressure Conditions	5-19
5-8	Minimum Size of Fillet Weld	5-24
5-9	Factors for Determining Values of k for Compression-Ring Bracing	5-25
5-10	Dimensions of Flush-Type Shell Connections (Inches)	5-45
6-1	Sidewall Plate Forming Schedule	6-1
6-2	Diameter Range Versus Radius Tolerance	6-2
6-3	Maximum Thickness of Reinforcement on Welds	6-4
6-4	Stress-Relieving Temperatures and Holding Times	6-5
7-1	Maximum Thickness of Reinforcement on Welds for Radiography Examined Joints	7-2
F-1	Computed Values of $(t - c)R$, s_c , s_p , and N for the Assumed Thicknesses: Example 1.	F-4
F-2	Computed Values of $(t - c)R$, s_c , s_p , and N for the Assumed Thicknesses: Example 2.	F-7
F-3	Cross-Sectional Area of Standard Angles: Example 1	F-10
L-1	Seismic Zone Tabulation for Some Areas Outside the United States	L-1
L-2	Seismic Zone Factor (Horizontal Acceleration)	L-2
L-3	Site Coefficients	L-6
Q-1	ASTM Materials for Primary Components	Q-2
Q-2	Charpy V-Notch Impact Values	Q-3
Q-3	Maximum Allowable Stress Values	Q-5
Q-4A	Minimum Thickness for the Annular Bottom Plate: Steel Tanks	Q-7
Q-4B	Minimum Thickness for the Annular Bottom Plate: Aluminum Tanks	Q-7
Q-5	Nominal Thickness of Inner Tank Cylindrical Sidewall Plates	Q-10
Q-6	Radius Tolerances for the Inner Tank Shell	Q-10
R-1	Material for Primary Components	R-2
R-2	Minimum Charpy V-Notch Impact Requirements for Primary-Component Plate Specimens (Transverse) and Weld Specimens Including the Heat-Affected Zone	R-3
R-3	Material for Secondary Components	R-3

	Page
R-4 Minimum Permissible Design Metal Temperature for Plates Used as Secondary Components Without Impact Testing	R-4
R-5 Minimum Charpy V-Notch Impact Requirements for Secondary-Component Plate Specimens (Transverse)	R-7
R-6 Thickness Requirements for the Annular Bottom Plate	R-8
S-1a ASTM Materials for Stainless Steel Components (SI Units)	S-1
S-1b ASTM Materials for Stainless Steel Components (US Customary Units)	S-2
S-2 Maximum Allowable Stress Values for Simple Tension	S-3
S-3 Allowable Stresses for Plate Ring Flanges	S-4
S-4 Yield Strength Values	S-4
S-5 Modulus of Elasticity at the Design Temperature	S-4
U-1 Flaw Acceptance Criteria for UT Indications (May be Used for All Materials)	U-3
U-2 Alternate Flaw Acceptance Criteria for UT Indications	U-4
U-3 Charpy V-notch Impact Values Required to Use Table U-2 for 9% Nickel Steel	U-4

04

For Committee Use Only

**For Committee
Use Only**

Design and Construction of Large, Welded, Low-Pressure Storage Tanks

SECTION 1—SCOPE

1.1 GENERAL

The API Downstream Segment has prepared this standard to cover large, field-assembled storage tanks of the type described in 1.2 that contain petroleum intermediates (gases or vapors) and finished products, as well as other liquid products commonly handled and stored by the various branches of the industry.

The rules presented in this standard cannot cover all details of design and construction because of the variety of tank sizes and shapes that may be constructed. Where complete rules for a specific design are not given, the intent is for the manufacturer—subject to the approval of the purchaser's authorized representative—to provide design and construction details that are as safe as those which would otherwise be provided by this standard.

The manufacturer of a low-pressure storage tank that will bear the API Std 620 nameplate shall ensure that the tank is constructed in accordance with the requirements of this standard.

The rules presented in this standard are further intended to ensure that the application of the nameplate shall be subject to the approval of a qualified inspector who has made the checks and inspections that are prescribed for the design, materials, fabrication, and testing of the completed tank.

1.2 COVERAGE

1.2.1 This standard covers the design and construction of large, welded, low-pressure carbon steel above ground storage tanks (including flat-bottom tanks) that have a single vertical axis of revolution. This standard does not cover design procedures for tanks that have walls shaped in such a way that the walls cannot be generated in their entirety by the rotation of a suitable contour around a single vertical axis of revolution.

1.2.2 The tanks described in this standard are designed for metal temperatures not greater than 250°F and with pressures in their gas or vapor spaces not more than 15 lbf/in.² gauge.

1.2.3 The basic rules in this standard provide for installation in areas where the lowest recorded 1-day mean atmospheric temperature is – 50°F. Appendix S covers stainless steel low-pressure storage tanks in ambient temperature service in all areas, without limit on low temperatures. Appendix R covers low-pressure storage tanks for refrigerated products at temperatures from + 40°F to – 60°F. Appendix Q covers low-pressure storage tanks for liquefied hydrocarbon gases at temperatures not lower than – 270°F.

1.2.4 The rules in this standard are applicable to tanks that are intended to (a) hold or store liquids with gases or vapors above their surface or (b) hold or store gases or vapors alone. These rules do not apply to lift-type gas holders.

1.2.5 Although the rules in this standard do not cover horizontal tanks, they are not intended to preclude the application of appropriate portions to the design and construction of horizontal tanks designed in accordance with good engineering practice. The details for horizontal tanks not covered by these rules shall be equally as safe as the design and construction details provided for the tank shapes that are expressly covered in this standard.

1.2.6 Appendix A provides information on the preparation and submission of technical inquiries as well as responses to recent inquiries.

1.2.7 Appendix B covers the use of plate and pipe materials that are not completely identified with any of the specifications listed in this standard.

1.2.8 Appendix C provides information on subgrade and foundation loading conditions and foundation construction practices.

1.2.9 Appendix D provides information about imposed loads and stresses from external supports attached to a tank wall.

1.2.10 Appendix E provides considerations for the design of internal and external structural supports.

1.2.11 Appendix F illustrates through examples how the rules in this standard are applied to various design problems.

1.2.12 Appendix G provides considerations for service conditions that affect the selection of a corrosion allowance; concerns for hydrogen-induced cracking effects are specifically noted.

1.2.13 Appendix H covers preheat and post-heat stress-relief practices for improved notch toughness.

1.2.14 Appendix I covers a suggested practice for peening weldments to reduce internal stresses.

1.2.15 Appendix J is reserved for future use.

1.2.16 Appendix K provides considerations for determining the capacity of tank venting devices.

1.2.17 Appendix L covers requirements for the design of storage tanks subject to seismic load.

1.2.18 Appendix M covers the extent of information to be provided in the manufacturer's report and presents a suggested format for a tank certification form.

1.2.19 Appendix N covers installation practices for pressure- and vacuum-relieving devices.

1.2.20 Appendix O provides considerations for the safe operation and maintenance of an installed tank, with attention given to marking, access, site drainage, fireproofing, water draw-off piping, and cathodic protection of tank bottoms.

02 **1.2.21** Appendix P summarizes the requirements for inspection by method of examination and the reference paragraphs within the standard. The acceptance standards, inspector qualifications, and procedure requirements are also provided. This appendix is not intended to be used alone to determine the inspection requirements within this standard. The specific requirements listed within each applicable section shall be followed in all cases.

1.2.22 Appendix Q covers specific requirements for the materials, design, and fabrication of tanks to be used for the storage of liquefied ethane, ethylene, and methane.

1.2.23 Appendix R covers specific requirements for the materials, design, and fabrication of tanks to be used for the storage of refrigerated products.

04 **1.2.24** Appendix S covers requirements for stainless steel tanks in non-refrigerated service.

1.2.25 Appendix U covers detailed rules for the use of the ultrasonic examination (UT) method for the examination of tank seams.

1.3 LIMITATIONS

1.3.1 General

The rules presented in this standard apply to vertical, cylindrical oil storage tanks built according to API Standard 650 as specifically allowed in 3.7.1.8, F.1, and F.7 of that standard. These rules do not apply to tanks built according to rules established for unfired pressure vessels designated for an internal pressure greater than 15 lbf/in.² gauge. **04**

1.3.2 Piping Limitations

The rules of this standard are not applicable beyond the following locations in piping connected internally or externally to the walls¹ of tanks constructed according to this standard:

- The face of the first flange in bolted flanged connections.
- The first threaded joint on the pipe outside the tank wall in threaded pipe connections.
- The first circumferential joint in welding-end pipe connections that do not have a flange located near the tank. (All nozzles larger than 2-in. pipe size that are connected to external piping shall extend outside the tank wall a minimum distance of 8 in. and shall terminate in a bolting flange.)

¹The term walls refers to the roof, shell and bottom of a tank as defined in 3.3. Tanks built according to Appendices Q and R may have both an inner and outer roof, shell and bottom. In these double-wall tanks, the piping that (a) may be subjected to the refrigerated product or gas in the annular space between the two tanks and (b) runs through the outer tank to the first circumferential joints must conform to the piping rules stated in Appendices Q and R.

SECTION 2—REFERENCES

The most recent editions or revisions of the following standards, codes, and specifications are cited in this standard.

- | | |
|--|---|
| <p>AA²
Specifications for Aluminum Structures—Allowable Stress Design and Commentary</p> <p>ACI³
318 <i>Building Code Requirements for Reinforced Concrete (ANSI/ACI 318)</i></p> <p>AISC⁴
Manual of Steel Construction</p> <p>API
Spec 5L <i>Specification for Line Pipe</i>
RP 520 <i>Sizing, Selection, and Installation of Pressure-Relieving Devices in Refineries, Part II, “Installation”</i>
Std 605 <i>Large-Diameter Carbon Steel Flanges (Nominal Pipe Sizes 26 Through 60; Classes 75, 150, 300, 400, 600, and 900)</i>
Std 650 <i>Welded Steel Tanks for Oil Storage</i>
Std 2000 <i>Venting Atmospheric and Low-Pressure Storage Tanks (Non-refrigerated and Refrigerated)</i></p> <p>ANSI⁵
H35.2 <i>Dimensional Tolerances for Aluminum Mill Products</i></p> <p>ASME⁶
B1.20.1 <i>General Purpose (in.) Pipe Threads (ANSI/ASME B1.20.1)</i>
B16.5 <i>Pipe Flanges and Flanged Fittings (ANSI/ASME B16.5)</i>
B31.1 <i>Power Piping</i>
B31.3 <i>Chemical Plant and Petroleum Refinery Piping (ANSI/ASME B31.3)</i>
B36.10M <i>Welded and Seamless Wrought Steel Pipe (ANSI/ASME B36.10)</i>
B96.1 <i>Welded Aluminum-Alloy Storage Tanks (ANSI/ASME B96.1)</i>
<i>Boiler and Pressure Vessel Code, Section V, “Nondestructive Examination”;</i> Section VIII, “Pressure</p> | <p>Vessels, Division 1”;</p> <p>ASNT⁷
CP-189 <i>Standard for Qualification and Certification of Nondestructive Testing Personnel</i>
SNT-TC-IA <i>Personnel Qualification and Certification in Nondestructive Testing</i></p> <p>ASTM⁸
A 6 <i>General Requirements for Rolled Steel Plates, Shapes, Steel Piling, and Bars for Structural Use</i>
A 20 <i>General Requirements for Steel Plates for Pressure Vessels</i>
A 27 <i>Steel Castings, Carbon, for General Application</i>
A 36 <i>Structural Steel</i>
A 53 <i>Pipe, Steel, Black and Hot-Dipped, Zinc-Coated Welded and Seamless</i>
A 105 <i>Forging, Carbon Steel, for Piping Components</i>
A 106 <i>Seamless Carbon Steel Pipe for High-Temperature Service</i>
A 131 <i>Structural Steel for Ships</i>
A 134 <i>Pipe, Steel, Electric-Fusion (Arc)-Welded (Sizes NPS 16 and Over)</i>
A 139 <i>Electric-Fusion (Arc) Welded Steel Pipe ([NPS] in 4 in. and Over)</i>
A 181 <i>Forgings, Carbon Steel, for General-Purpose Piping</i>
A 182 <i>Forged or Rolled Alloy-Steel Pipe Flanges, Forged Fittings, and Valves and Parts for High-Temperature Service</i>
A 193 <i>Alloy-Steel and Stainless Bolting Materials for High-Temperature Service</i>
A 194 <i>Carbon and Alloy Steel Nuts for Bolts for High-Pressure and High-Temperature Service</i>
A 213 <i>Seamless Ferritic and Austenitic Alloy-Steel Boiler, Superheater, and Heat Exchanger Tubes</i>
A 240 <i>Heat-Resisting Chromium and Chromium-Nickel Stainless Steel Plate, Sheet, and Strip for Pressure Vessels</i>
A 283 <i>Low and Intermediate Tensile Strength Carbon Steel Plates</i>
A 285 <i>Pressure Vessel Plates, Carbon Steel, Low- and Intermediate-Tensile Strength</i></p> |
|--|---|

²Aluminum Association, 900 19th Street, N.W., Washington D.C. 20006, www.aluminum.org.

³American Concrete Institute, P.O. Box 19150, Redford Station, Detroit, Michigan 48219, www.aci-int.org.

⁴American Institute of Steel Construction, 400 North Michigan Avenue, Chicago, Illinois 60611-4185, www.aisc.org.

⁵American National Standards Institute, 1430 Broadway, New York, New York 10018, www.ansi.org.

⁶American Society of Mechanical Engineers, 345 East 47th Street, New York, New York 10017, www.asme.org.

⁷American Society for Nondestructive Testing, 4153 Arlington Plaza, Columbus, Ohio 43228-0518, www.asnt.org.

⁸American Society for Testing and Materials, 100 Barr Harbor Drive, West Conshohocken, PA 19428-2959, www.astm.org.

	A 307	<i>Carbon Steel Bolts and Studs, 60,000 psi Tensile Strength</i>	A 673	<i>Sampling Procedure for Impact Testing of Structural Steel</i>	
	A 312	<i>Seamless and Welded Austenitic Stainless Steel Pipe</i>	A 678	<i>Quenched and Tempered Carbon-Steel and High-Strength Low-Alloy Steel Plates for Structural Applications</i>	
	A 320	<i>Alloy Steel Bolting Materials for Low-Temperature Service</i>	A 737	<i>Pressure Vessel Plates, High-Strength, Low-Alloy Steel</i>	
	A 333	<i>Seamless and Welded Steel Pipe for Low-Temperature Service</i>	A 841	<i>Steel Plates for Pressure Vessels, Produced by Thermo-Mechanical Process (TMCP)</i>	
	A 334	<i>Seamless and Welded Carbon and Alloy-Steel Tubes for Low-Temperature Service</i>	A 992	<i>Steel for Structural Shapes for Use in Building Framing</i>	02
	A 350	<i>Forgings, Carbon and Low-Alloy Steel, Requiring Notch Toughness Testing for Piping Components</i>	B 209	<i>Aluminum and Aluminum-Alloy Sheet and Plate</i>	
04	A 351	<i>Castings, Austenitic, Austenitic-Ferritic (Duplex), for Pressure-Containing Parts</i>	B 210	<i>Aluminum-Alloy Drawn Seamless Tubes</i>	
	A 353	<i>Pressure Vessel Plates, Alloy Steel, 9% Nickel, Double-Normalized and Tempered</i>	B 211	<i>Aluminum and Aluminum-Alloy Bars, Rods, and Wire</i>	
	A 358	<i>Electric-Fusion-Welded Austenitic Chromium-Nickel Alloy Steel Pipe for High-Temperature Service</i>	B 221	<i>Aluminum-Alloy Extruded Bars, Rods, Wire, Shapes, and Tubes</i>	
	A 370	<i>Test Methods and Definitions for Mechanical Testing of Steel Products</i>	B 241	<i>Aluminum-Alloy Seamless Pipe and Seamless Extruded Tube</i>	
	A 403	<i>Wrought Austenitic Stainless Steel Piping Fittings</i>	B 247	<i>Aluminum and Aluminum-Alloy Die, Hand and Rolled Ring Forgings</i>	
04	A 479	<i>Stainless Steel Bars and Shapes for Use in Boilers and Other Pressure Vessels</i>	B 308	<i>Aluminum-Alloy 6061-T6 Standard Structural Shapes, Rolled or Extruded</i>	
	A 480	<i>General Requirements for Flat-Rolled Stainless and Heat-Resisting Steel Plate, Sheet, and Strip</i>	B 444	<i>Nickel-Chromium-Molybdenum-Columium Alloys (UNS N06625) Pipe and Tube</i>	
	A 516	<i>Pressure Vessel Plates, Carbon Steel, for Moderate and Lower Temperature Service</i>	B 619	<i>Welded Nickel and Nickel-Cobalt Alloy Pipe</i>	
	A 522	<i>Forged or Rolled Eight and 9% Nickel Alloy Steel Flanges, Fittings, Valves and Parts for Low Temperature Service</i>	B 622	<i>Seamless Nickel and Nickel-Cobalt Alloy Pipe and Tube</i>	
	A 524	<i>Seamless Carbon Steel Pipe for Atmospheric and Lower Temperatures</i>	E 23	<i>Notched Bar Impact Testing of Metallic Materials</i>	
	A 537	<i>Pressure Vessel Plates, Heat Treated, Carbon-Manganese-Silicon Steel</i>	AWS ⁹		
	A 553	<i>Pressure Vessel Plates, Alloy Steel, Quenched and Tempered Eight and 9% Nickel</i>	A5.11	<i>Nickel and Nickel Alloy Covered Welding Electrodes (ANSI/AWS A5.11)</i>	
	A 573	<i>Structural Carbon Steel Plates of Improved Toughness</i>	A5.14	<i>Nickel and Nickel Alloy Bare Welding Rods and Electrodes (ANSI/AWS A5.14)</i>	
	A 633	<i>Normalized High-Strength Low-Alloy Structural Steel</i>	CSA ¹⁰		
	A 645	<i>Pressure Vessel Plates, 5% Nickel Alloy Steel, Specially Heat Treated</i>	G40.21	<i>Structural Quality Steel</i>	04
	A 662	<i>Pressure Vessel Plates, Carbon-Manganese, for Moderate and Lower Temperature Service</i>	ISO ¹¹		
	A 671	<i>Electric-Fusion-Welded Steel Pipe for Atmospheric and Lower Temperatures</i>	630	<i>Structural Steels</i>	

⁹American Welding Society, 550 N.W. LeJeune Road, Miami, Florida 33135, www.aws.org.

¹⁰Canadian Standards Association, 178 Rexdale Boulevard, Rexdale, Ontario M9W 1R3, www.csa.ca.

¹¹International Organization for Standardization. ISO publications can be obtained from national standards organizations such as ANSI, www.iso.ch.

SECTION 3—DEFINITIONS

3.1 STRESS AND PRESSURE TERMS

3.1.1 maximum allowable stress value: The maximum unit stress permitted to be used in the design formulas given or provided for in this standard for the specific kind of material, character of loading, and purpose for a tank member or element (see 5.5 and 5.6).

- 04| **3.1.2 design pressure:** The maximum positive gauge pressure permissible at the top of a tank when the tank is in operation. It is the basis for the pressure setting of the safety-relieving devices on the tank. The design pressure is synonymous with the **nominal pressure rating** for the tank as referred to in this standard (see 5.3.1).

3.2 CAPACITY TERMS

3.2.1 nominal liquid capacity: The total volumetric liquid capacity of a tank (excluding deadwood) between the plane of the high liquid design level and elevation of the tank grade immediately adjacent to the wall of the tank or such other low liquid design level as the manufacturer shall stipulate.

3.2.2 total liquid capacity: The total volumetric liquid capacity of a tank (excluding deadwood) below the high liquid design level.

3.3 TANK WALL

The tank wall is any or all parts of the plates located in the surface of revolution that bounds the tank and serves to separate the interior of the tank from the surrounding atmosphere. Flat bottoms of cylindrical tanks are covered by the rules of 5.9.4. As such, the tank walls include the sidewalls (or shell), roof, and bottom of the tank but not any of the following elements located on or projecting from the walls:

- Nozzles and manways or their reinforcement pads or cover plates.
- Internal or external diaphragms, webs, trusses, structural columns, or other framing.
- Those portions of a compression-ring angle, bar, or girder that project from the walls of the tank.
- Miscellaneous appurtenances.

3.4 WELDING TERMS

The terms defined in 3.4.1 through 3.4.15 are commonly used welding terms mentioned in this standard. See 5.22 for descriptions of fusion-welded joints.

3.4.1 backing: The material—metal, weld metal, carbon, granular flux, and so forth—that backs up the joint during welding to facilitate obtaining a sound weld at the root.

3.4.2 base metal: The metal to be welded or cut.

3.4.3 depth of fusion: The distance that fusion extends into the base metal from the surface melted during welding.

3.4.4 filler metal: Metal added in making a weld.

3.4.5 fusion: The melting together of filler metal and base metal, or the melting of base metal only, which results in coalescence.

3.4.6 heat-affected zone: The portion of the base metal that has not been melted but whose mechanical properties or microstructures have been altered by the heat of welding or cutting.

3.4.7 joint penetration: The minimum depth a groove weld extends from its face into a joint, exclusive of reinforcement.

3.4.8 lap joint: A joint between two overlapping members. An overlap is the protrusion of weld metal beyond the bond at the toe of the weld.

3.4.9 oxygen cutting: A group of cutting processes wherein the severing of metals is effected by means of the chemical reaction of oxygen with the base metal at elevated temperatures. In the case of oxidation-resistant metals, the reaction is facilitated by use of a flux.

3.4.10 porosity: The existence of gas pockets or voids in metal.

3.4.11 reinforcement of weld: Weld metal on the face of a groove weld in excess of the metal necessary for the specified weld size.

3.4.12 slag inclusion: Nonmetallic solid material entrapped in weld metal or between weld metal and base metal.

3.4.13 undercut: A groove melted into the base metal adjacent to the toe of a weld and left unfilled by weld metal.

3.4.14 welded joint: A union of two or more members produced by the application of a welding process.

3.4.15 weld metal: The portion of a weld that has been melted during welding.

3.4.16 machine welding: Welding with equipment that performs the welding operation under the constant observation and control of a welding operator. The equipment may or may not perform the loading and unloading of the work.

3.4.17 manual welding: Welding wherein the entire welding operation is performed and controlled by hand.

3.4.18 semiautomatic arc welding: Arc welding with equipment that controls only the filler metal feed. The advance of the welding is manually controlled.

3.4.19 welder: One who performs manual or semiautomatic welding.

3.4.20 welding operator: One who operates machine welding equipment.

**For Committee
Use Only**

SECTION 4—MATERIALS

4.1 GENERAL

4.1.1 Material Specifications

04 | Materials used in the construction of API Standard 620 tanks shall comply with the specifications in this section (see Appendices Q, R, and S for specific material requirements). Material produced to specifications other than those listed in this section may be used if the material is certified to meet all the requirements of a material specification listed in this section and that its use is approved by the purchaser.

4.1.2 Materials That Cannot Be Completely Identified

Any plate materials or tubular products on hand that cannot be completely identified with a specification listed in this standard, by records satisfactory to the inspector, may be used to construct tanks according to the rules of this standard if the material passes the test prescribed in Appendix B.

4.1.3 Accessory Pressure Parts

All accessory pressure parts, such as pipe fittings, valves, flanges, nozzles, welding necks, welding caps, manhole frames, and covers, shall be made from materials provided for in this standard or in any accepted ANSI standard that covers the particular part. These parts shall be marked with the name or trademark of the manufacturer and any other markings that are required by the applicable standards. Such markings shall be considered the manufacturer's guarantee that the product complies with the material specifications and standards indicated and is suitable for service at the rating indicated. The intent of this paragraph will have been met if, in lieu of the detailed marking on the part itself, the accessory pressure parts have been marked in any permanent or temporary manner that serves to identify the part with the manufacturer's written listing of the particular items and if this listing is available for examination by the inspector.

4.1.4 Small Parts

Cast, forged, or rolled parts of small size (which are ordinarily carried in stock and for which mill test reports or certificates are not customarily furnished) may be used if, in the opinion of the inspector, they are suitable for the purpose intended and that, if such parts are to be welded, they are of welding grade.

4.2 PLATES

4.2.1 General

4.2.1.1 All plates that are subject to pressure-imposed membrane stress or are otherwise important to the structural

integrity of a tank, including bottom plates welded to the cylindrical sidewall of flat-bottom tanks, shall conform to specifications selected to provide a high order of resistance to brittle fracture at the lowest temperature to which the metal in the walls of the tank is expected to fall on the coldest days of record for the locality where the tank is to be installed.

4.2.1.2 In all cases, the purchaser shall specify the design metal temperature, and the plates used for the tank shall conform to one or more of the specifications listed in Table 4-1 as being acceptable for use at that temperature. Except as otherwise provided in the last sentence of this paragraph and in 4.2.2, the design metal temperature for materials in contact with nonrefrigerated fluids shall be assumed to be 15°F above the lowest one-day mean ambient temperature for the locality involved, as determined from Figure 4-1. For locations not covered by Figure 4-1, authentic meteorological data shall be used. Where no such data are available, the purchaser shall estimate the temperature from the most reliable information at hand. Where special means, such as covering the outside of the tank with insulation or heating the tank contents, are provided to ensure that the temperature of the tank walls never falls to within 15°F of the lowest one day mean ambient temperature, the design metal temperature may be set at a higher level that can be justified by computations or by actual temperature data on comparable existing tanks.

4.2.1.3 Unless exempted per 4.2.2, notch toughness of specially designed plate flanges and cover plates shall be evaluated using governing thickness in Table 4-1. (See 4.3.5.3 for definition of governing thickness.)

4.2.2 Low-Stress Design

The following design criteria, relative to the use of Table 4-1, apply when the actual stress under design conditions does not exceed one-third of the allowable tensile stress:

- a. Consideration of the design metal temperature is not required in selecting material from Table 4-1 for tank components that are not in contact with the liquid or vapor being stored and are not designed to contain the contents of an inner tank (see Q.2.3 and R.2.2).
- b. The design metal temperature may be increased by 30°F in selecting material from Table 4-1 for tank components that are exposed to the vapor from the liquid or vapor being stored and are not designed to contain the contents of an inner tank.
- c. Excluding bottom plates welded to the cylindrical sidewall of flat-bottom tanks, the plates of a non refrigerated flat-bottom tank, counterbalanced in accordance with 5.11.2, may be constructed of any material selected from Table 4-1.

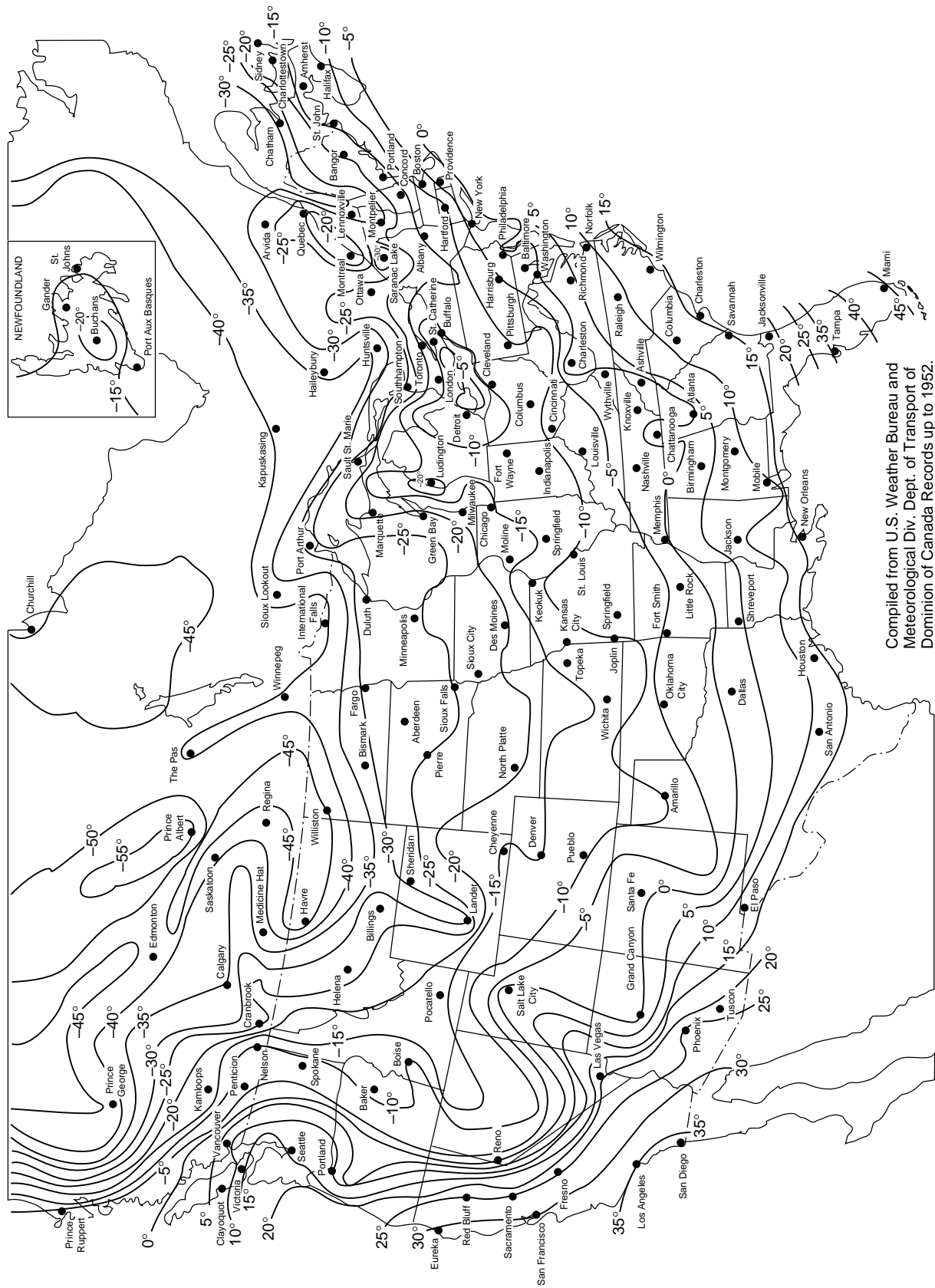

Compiled from U.S. Weather Bureau and
Meteorological Div. Dept. of Transport of
Dominion of Canada Records up to 1952.

Figure 4-1—Isothermal Lines Showing 1-Day Mean Ambient Temperature

Table 4-1—Minimum Requirements for Plate Specifications to be Used for Design Metal Temperatures

Design Metal Temperature (see 4.2.1)	Plate Thickness Including Corrosion Allowance (in.)	Permissible Specifications				
		Specification	Grade	Special Requirements (in addition to 4.2.3)		
65°F and over	≤ 3/4	Any listed in 4.2.3	—	None	04	
	≤ 1	ASTM A 36	—	None		
	> 1	CSA G40.21	38W, 44W, 50W	Note 1		
25°F and over	≤ 1/2	Any listed in 4.2.3	—	None	04	
	≤ 1	ASTM A 36 Mod 2	—	None		
		ASTM A 131	B	None		
		CSA G40.21	38W, 44W, 50W	None		
– 5°F and over	> 1			Note 1	04	
	≤ 1/2	ASTM A 131	B	None		
		CSA G40.21	38W, 44W, 50W	None		
	> 1/2	ASTM A 131	CS	None		
		ASTM A 516	55, 60, 65, 70	Note 1		
		ASTM A 573	58, 65, 70	Note 1		
		ASTM A 662	B and C	Note 1		
		ASTM A 737	B	None		
		ASTM A 841	Class 1	None		
		CSA G40.21	38W, 44W, 50W	Note 2		
– 35°F and over		ISO 630	E 275, E355 Quality D	Notes 1 and 2	04	
	≤ 1/2	ASTM A 131	CS	None		
		ASTM A 516	55, 60, 65, 70	None		
		ASTM A 537	Classes 1 and 2	None		
		ASTM A 573	58, 65, 70	None		
		ASTM A 633	C and D	None		
		ASTM A 662	B and C	None		
		ASTM A 678	A and B	None		
		ASTM A 737	B	None		
		ASTM A 841	Class 1	None		
		CSA G40.21	38W, 44W, 50W	Note 2		
		ISO 630	E 275, E355 Quality D	Notes 1 and 2		
		> 1	ASTM A 131	CS		None
			ASTM A 516	55, 60, 65, 70		Note 3
			ASTM A 537	Classes 1 and 2		None
			ASTM A 573	58		Note 3
	ASTM A 633		C and D	None		
	ASTM A 662		B and C	Note 3		
	ASTM A 678		A and B	None		
	ASTM A 737		B	None		
	ASTM A 841		Class 1	None		
	CSA G40.21		38W, 44W, 50W	Notes 2 and 3		
	ISO 630		E275, E355 Quality D	Notes 2 and 3		
			ASTM A 131	CS		Note 4
			ASTM A 516	55, 60, 65, 70		Notes 3 and 4
			ASTM A 537	Classes 1 and 2		Note 4
			ASTM A 573	58		Notes 3 and 4
		ASTM A 633	C and D	Note 4		
		ASTM A 662	B and C	Notes 3 and 4		
		ASTM A 678	A and B	Note 4		
	ASTM A 737	Class 1	Note 4			
	ASTM A 841	B	None			
	CSA G40.21	38W, 44W, 50W	Notes 2, 3, and 4			
	ISO 630	E275, E355 Quality D	Notes 2, 3, and 4			

Notes:

1. All plates over 1 1/2 in. thick shall be normalized.
2. The steel shall be killed and made with fine-grain practice.
3. The plates shall be normalized or quench tempered (see 4.2.4.2).
4. Each plate shall be impact tested in accordance with 4.2.5.

04

04

04

04

02

04

02

04

02

04

04

4.2.3 Plate Specifications

4.2.3.1 General

The specifications listed in 4.2.3.2 through 4.2.3.4 are approved for plates, subject to the modifications and limitations of this paragraph, 4.2.4, and Table 4-1.

4.2.3.2 ASTM Specifications

The following ASTM specifications are approved for plates:

- a. A 20.
- b. A 36, with the following API modification as required (see Table 4-1 and Appendix R): Mod 2 requires the manganese content to have a range of 0.80 – 1.20. The material supplied shall not be rimmed or capped steel.
- c. A 131 (structural quality only).
- d. A 283 (Grades C and D only, with a maximum nominal thickness of $\frac{3}{4}$ in.).
- e. A 285 (Grade C only, with a maximum nominal thickness of $\frac{3}{4}$ in.).
- f. A 516, with the following API modifications as required (see Appendix R): Mod 1 requires the carbon content to be restricted to a maximum of 0.20% by ladle analysis; a maximum manganese content of 1.50% shall be permitted. Mod 2 requires the minimum manganese content to be lowered to 0.70% and the maximum increased to 1.40% by ladle analysis. The carbon content shall be limited to a maximum of 0.20% by ladle analysis. The steel shall be normalized. The silicon content may be increased to a maximum of 0.50% by ladle analysis.
- g. A 537, with the following modification: The minimum manganese content shall be 0.80% by ladle analysis. The maximum manganese content may be increased to 1.60% by ladle analysis if maximum carbon content is 0.20% by ladle analysis.
- h. A 573.
- i. A 633 (Grades C and D only).
- j. A 662 (Grades B and C only).
- k. A 678 (Grades A and B only).
- l. A 737 (Grade B only).
- m. A 841 (Class 1 only).

4.2.3.3 CSA Specification

The following CSA specification is approved for plates: G40.21 (Grades 38W, 44W, and 50W only; if impact tests are required, these grades are designated 38WT, 44WT, and 50WT).

Elements added for grain strengthening shall be restricted in accordance with Table 4-2. Plates shall have a tensile strength not more than 20 ksi above the minimum specified for the grade. Fully killed steel made to a fine grain practice must be specified when required.

Table 4-2—Maximum Permissible Alloy Content

Alloy	%	Notes
Columbium	0.05	1, 2, and 3
Vanadium	0.10	1, 2, and 4
Columbium (0.05–% maximum) plus vanadium	0.10	1, 2, and 3
Nitrogen	0.015	1, 2, and 4
Copper	0.35	1 and 2
Nickel	0.50	1 and 2
Chromium	0.25	1 and 2
Molybdenum	0.08	1 and 2

Notes:

1. When not included in the material specification, the use of these alloys, or combinations thereof, shall be at the option of the plate producer, subject to the approval of the purchaser. These elements shall be reported when requested by the purchaser.
2. The material shall conform to these requirements on product analysis subject to the product analyses tolerances of the specification.
3. Columbium, when added either singly or in combination with vanadium, shall be restricted to plates of 0.50-in. maximum thickness unless it is combined with a minimum of 0.15% silicon.
4. When added as a supplement to vanadium, nitrogen (a maximum of 0.015%) shall be reported and the minimum ratio of vanadium to nitrogen shall be 4:1.

4.2.3.4 ISO Publication

The following ISO publication is approved for plates: 630 (Grades E275 and E355 in Qualities C and D only). For E275, the maximum percentage of manganese shall be 1.50 by ladle analysis. Elements added for grain refining or strengthening shall be restricted in accordance with Table 4-2.

4.2.4 Plate Manufacture

4.2.4.1 All material for plates shall be made using the open-hearth, electric-furnace, or basic-oxygen process. Universal mill plates shall not be used. All plates for pressure parts, with the exception of those whose thicknesses are established by the requirements of Table 5-6, shall be ordered on the basis of edge thickness to ensure that the plates furnished from the mill will not underrun the specified thickness by more than 0.01 in. This stipulation shall not be construed to prohibit the use of plates purchased based on weight if it is established by actual measurements (taken at a multiplicity of points along the edges of the plates) that the minimum thicknesses of the plates do not underrun the required design thickness by more than 0.01 in.

4.2.4.2 Subject to the approval of the purchaser, controlled-rolled or thermo-mechanical control process (TMCP) plates (material produced by a mechanical-thermal rolling process designed to enhance the notch toughness) may be used where normalized plates are required. Each plate, as

rolled, shall be Charpy V-notch tested according to the requirements of R.2.1.2.

4.2.5 Impact Test Specimens

When required by Table 4-1, each plate shall be impact tested; plate refers to the unit plate rolled from a slab or directly from an ingot. The ASTM A 370, Type A, Charpy V-notch test shall be used. The long dimension of the specimen shall be parallel to the direction of the expected maximum stress. When the coincident stresses are approximately equal, the specimens shall be taken transverse to the final direction of the plate rolling. The requirements of R.2.1.2 shall be satisfied, except that the minimum energy absorption values of Table R-5 may be substituted for those of Table R-2.

4.3 PIPE, FLANGES, FORGING, AND CASTINGS

All pipe, flanges, forgings, and castings used in the parts of the tanks that are subject to internal pressure shall conform to applicable requirements of 4.3.1 to 4.3.5 inclusive.

4.3.1 Pipe¹²

4.3.1.1 Carbon steel pipe shall conform to one of the following specifications:

- a. ASTM A 53.
- b. ASTM A 106.
- c. ASTM A 134, excluding helical (spiral) welded pipe.
- d. ASTM A 139, excluding helical (spiral) welded pipe.
- e. ASTM A 333.
- f. ASTM A 524.
- g. ASTM A 671 (Grades CA, CC, CD, and CE only).
- h. API Specification 5L (Grades A and B only).

4.3.1.2 When ASTM A 134, A 139, or A 671 pipe is used, it shall comply with the following:

- a. The pipe shall be certified to have been pressure tested.
- b. The plate specification for the pipe shall satisfy the requirements of 4.2.3, 4.2.4, and 4.2.5 that are applicable to that plate specification.
- c. Impact tests for qualifying the welding procedure for the pipe longitudinal welds shall be performed in accordance with 4.7.1.

4.3.2 Built-Up Fittings

Built-up fittings, such as ells, tees, and return bends, may be fabricated by fusion welding when they are designed according to the applicable paragraphs in this standard.

¹²For design metal temperatures below -20°F , the materials shall conform to Tables R-1 and/or R-3.

4.3.3 Flanges

4.3.3.1 Hub, slip-on welding neck and long welding neck flanges shall conform to the material requirements of ASME B16.5 for forged carbon steel flanges. Plate material used for nozzle flanges shall have physical properties better than or equal to those required by ASME B16.5. Plate flange material shall conform to 4.2.3.

4.3.3.2 For nominal pipe sizes greater than 24 in., flanges that conform to ASME B16.47, Series B, may be used, subject to the purchaser's approval. Particular attention should be given to ensuring that mating flanges of appurtenances are compatible.

4.3.4 Castings and Forgings

Large castings and forgings (see Footnote 12 for both materials) not covered in 4.1.3 shall be of welding grade if welding is to be done on them, and they shall conform to one of the following ASTM specifications:

- a. A 27 (Grade 60-30, for structural parts only).
- b. A 105.
- c. A 181.
- d. A 350.

4.3.5 Toughness Requirements

Except as covered in 4.3.1.2, the toughness requirements of pipe, flanges, and forgings shall be established as described in 4.3.5.1 through 4.3.5.4.

4.3.5.1 No impact testing is required for ASME B16.5 ferritic steel flanges used at minimum design metal temperature, no colder than -20°F . Piping materials made according to ASTM A 333 and A 350 may be used at a minimum design metal temperatures, no lower than the impact test temperature required by the ASTM specification for the applicable material grade, unless additional impact tests (see 4.3.5.4) are conducted.

4.3.5.2 Other pipe and forging materials shall be classified under the material groups shown in Figure 4-2 as follows:

- a. Group I—API Spec 5L, Grades A, B, ASTM A 106, Grades A and B; ASTM A 53, Grades A and B; ASTM A 181; and ASTM A 105.
- b. Group II—ASTM A 524, Grades I and II.

4.3.5.3 The materials in the groups listed in 4.3.5.2 may be used at nominal thicknesses, including corrosion allowance, at minimum design metal temperatures no lower than those shown in Figure 4-2 without impact testing (see 4.3.5.4). The

governing thickness (see Figure 4-3) to be used in Figure 4-2 shall be as follows:

- a. For butt-welded joints, it is the nominal thickness of the thickest welded joint.
- b. For corner weld (groove or fillet) or lap welds, it is the thinner of the two parts joined.
- c. For nonwelded parts (such as bolted flanges), it is $\frac{1}{4}$ of flat cover nominal thickness.

4.3.5.4 When impact tests are required by 4.3.5.2 or 4.3.5.3, they shall be performed in accordance with the requirements, including minimum energy requirements of ASTM A 333, Grade 1 for pipe, or ASTM A 350 Grade LF1, for forgings at a test temperature no higher than the minimum design metal temperature. Except for the plate specified in 4.2.3, the material specified in 4.3 shall have a minimum Charpy V-notch impact strength of 13 ft-lbs (full size specimen) at a temperature no higher than the minimum design metal temperature.

4.4 BOLTING MATERIAL

Carbon steel bolts¹³ may be used if they conform to the following, or to better,¹⁴ specifications:

- a. ASTM A 193.
- b. ASTM A 307.
- c. ASTM A 320.

4.5 STRUCTURAL SHAPES

All structural shapes (see footnote 12) that are subject to pressure-imposed loads or are otherwise important to the structural integrity of a tank shall be made only by the open-hearth, electric-furnace, or basic-oxygen process and shall conform to one of the following specifications:

- a. ASTM A 36 and the following API modification as required (see Appendix R): Mod 1 requires the steel to be made with fine grain practice, with manganese content in the range of 0.80-1.20% of by ladle analysis.
- b. ASTM A 131.
- c. ASTM A 633 (Grade A only).
- d. ASTM A 992.
- e. CSA G40.21 (Grades 38W, 44W, and 50W only; if impact tests are required, these grades are designated 38WT, 44WT, and 50WT).

¹³For design metal temperatures below -20°F , the materials shall conform to Tables R-1 and/or R-3.

¹⁴If better grades of bolts are used, higher bolt stress values are not recommended with full-faced gaskets.

04

02

04

For Comment Use Only

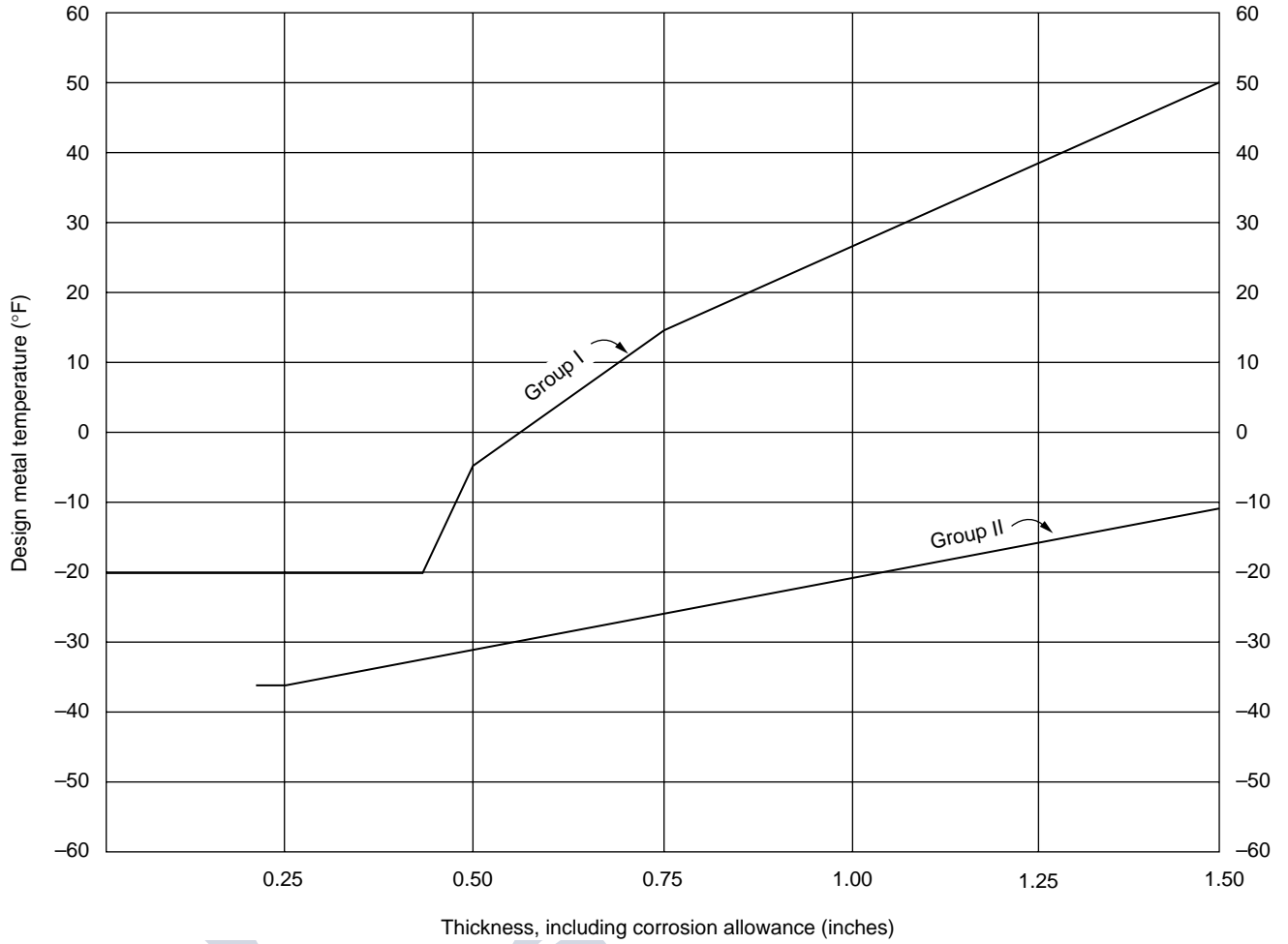
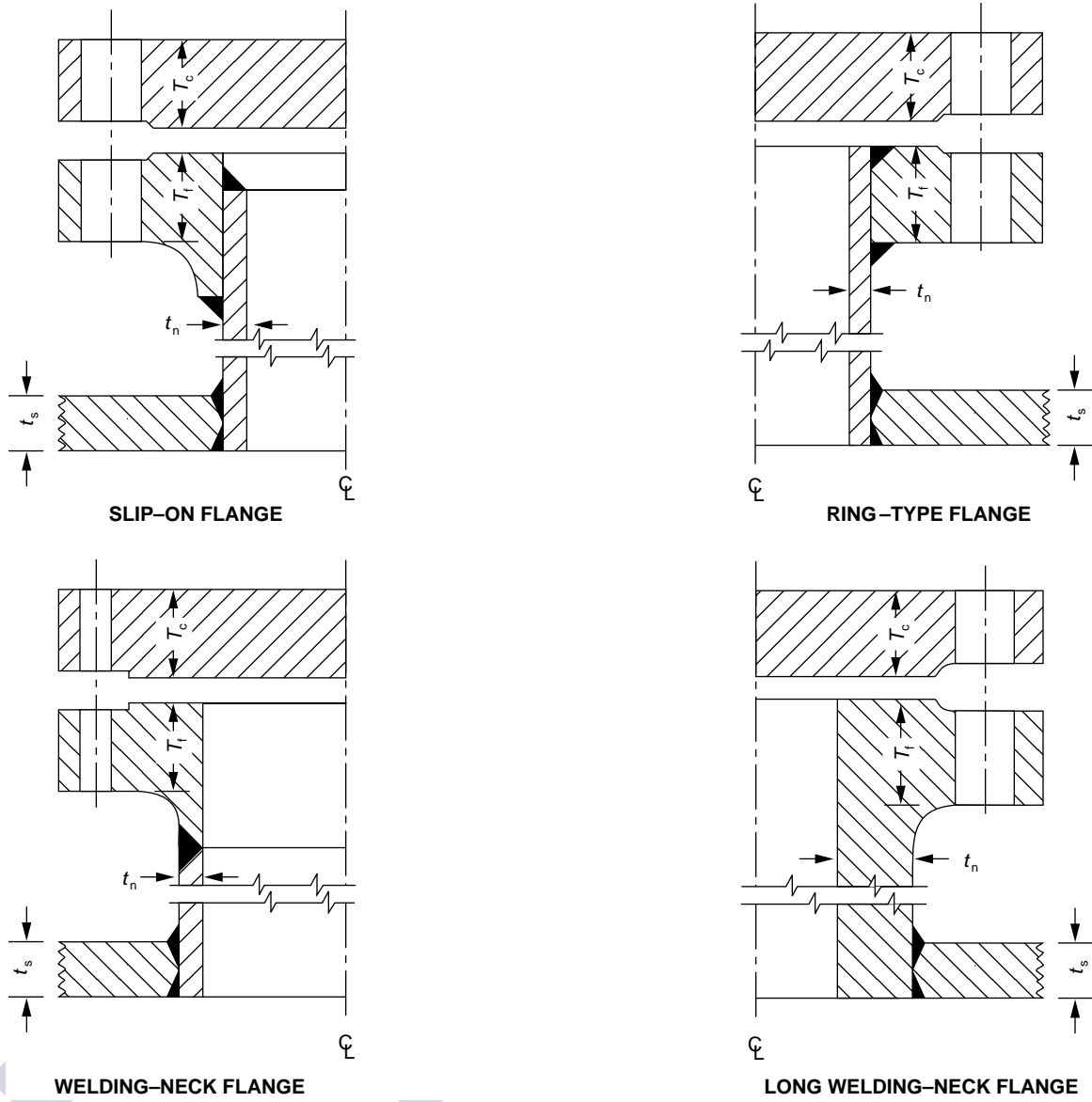

Figure 4-2—Minimum Permissible Design Metal Temperature for Pipe, Flanges, and Forgings without Impact Testing | 04



- 04 | 1. Shell reinforcing plate is not included in the illustration above.
- 2. t_s = shell thickness; t_n = nozzle neck thickness; T_f = flange thickness; T_c = bolted cover thickness.
- 3. The governing thickness for each component shall be as follows:

Components	Governing Thickness (whichever is less)
Nozzle neck	t_n or t_s
Slip-on flange	t_n or T_f
Ring-type flange	t_n or T_f
Welding-neck flange	t_n or T_f
Long welding-neck flange	t_n or t_s
Bolted cover	$1/4 T_c$

Figure 4-3—Governing Thickness for Impact Test Determination of Pipe, Flanges, and Forgings

SECTION 5—DESIGN

5.1 GENERAL

5.1.1 Scope of Rules

The rules presented in this standard are intended to establish approved engineering practices for low-pressure storage tanks constructed of any shape within the scope of 1.2 and to provide the fundamental rules for design and testing, which can serve as a sufficient basis for an inspector to judge the safety of any vessel and improve the application of the API 620 nameplate. Where these rules do not cover all details of design and construction, the manufacturer, subject to the approval of the authorized inspector, shall provide details of design and construction that will be as safe as those provided by this standard.

5.1.2 Pressure Chambers

For tanks that consist of two or more independent pressure chambers and have a roof, bottom, or other elements in common, each pressure part shall be designed for the most severe combination of pressure or vacuum that can be experienced under the specified operating conditions.

5.1.3 Avoidance of Pockets

Tank walls shall be shaped to avoid any pockets on the inside where gases may become trapped when the liquid level is being raised or on the outside where rainwater may collect.

5.1.4 Volume of Vapor Space

The volume of the vapor space above the high liquid design level upon which the nominal capacity is based shall be not less than 2% of the total liquid capacity (see 3.2.2).

5.1.5 Tests of New Design

When a tank is of a new design and has (a) an unusual shape or (b) large branches or openings that may make the stress system around these locations in the tank wall unsymmetrical to a degree that, in the judgment of the designer, does not permit computation with a satisfactory assurance of safety, the tank shall be subjected to a proof test, and strain-gauge surveys shall be made as provided in 7.24.

5.2 OPERATING TEMPERATURE

The temperature of the liquids, vapor, or gases stored in, or entering, these tanks shall not exceed 250°F (see 1.2.2).

5.3 PRESSURES USED IN DESIGN

5.3.1 Above Maximum Liquid Level

5.3.1.1 The walls of the gas or vapor space and other tank components that are above the maximum liquid level at the top of the tank shall be designed for a pressure not less than that at which the pressure relief valves are to be set; they shall be designed for the maximum partial vacuum that can be developed in the space when the inflow of air (or another gas or vapor) through the vacuum relief valves is at its maximum specified rate. The maximum positive gauge pressure for which this space is designed shall be understood to be the nominal pressure rating for the tank (sometimes referred to as the design pressure) and shall not exceed 15 lbf/in.² gauge.

5.3.1.2 When a tank is to operate at liquid levels that at no time reach the top of the roof but the tank will be filled to the top of the roof during the hydrostatic test as provided in 7.18.4, the tank must be designed for both maximum liquid-level conditions, using in each case the weight of liquid specified in 5.3.3.

5.3.1.3 A suitable margin shall be allowed between the pressure that normally exists in the gas or vapor space and the pressure at which the relief valves are set; this margin allows for pressure increases caused by variations in the temperature or gravity of the liquid contents of the tank and by other factors that affect the pressure in the gas or vapor space.

5.3.1.4 The maximum partial vacuum will be greater than that at which the vacuum relief valves are set to open.

5.3.2 Below Maximum Liquid Level

All portions of the tank at levels below the aforementioned maximum liquid level shall have each of their important elements designed for at least the most severe combination of gas pressure (or partial vacuum) and static liquid head affecting the element in any specified operation as the pressure in the gas or vapor space varies between the lowest and highest limits encountered during operation.

5.3.3 Weight for Liquid Storage

The weight for liquid storage shall be assumed to be the weight per ft³ of the specified liquid contents at 60°F, but in no case shall the minimum weight be less than 48 lb/ft³. This minimum weight does not apply to tanks used for gas storage only, or used for refrigerated liquid storage as discussed in Appendixes Q and R.

5.4 LOADINGS

The following loadings shall be considered in the design of large, low-pressure storage tanks:

- The internal pressure as specified in 5.3 and any partial vacuum resulting from operation.
- The weight of the tank and specified contents, from empty to full, with or without the maximum gas pressure specified.
- The supporting system, both localized and general, including the effect that is predictable from the nature of the foundation conditions (see Appendices C and D).
- Superimposed loading, such as platforms and brackets for stairways and, where climatic conditions warrant, excessive snow (see Appendix E).
- Wind loads or, when specified, earthquake loadings (see 5.5.6).
- Loads resulting from connected piping.
- The weight of any insulation and linings.

5.5 MAXIMUM ALLOWABLE STRESS FOR WALLS¹⁵

5.5.1 General

Higher localized shear and secondary bending stresses may exist in the walls of tanks designed and fabricated according to this standard, and the prescribed test loadings may result in some localized reshaping. This is permissible, since localized reshaping is expected as part of a legitimate fabrication operation, if the reshaping is not so severe that upon release of the test pressure, plastic straining occurs in the opposite direction. This would tend to develop continuing plastic straining in subsequent normal operation.

5.5.2 Nomenclature

5.5.2.1 Variables relating to stresses common to the requirements of 5.5.3 through 5.5.5 and Figure 5-1 are defined as follows:

- t = thickness of the wall, in.,
- R = radius of the wall, in.,
- c = corrosion allowance, in.,
- S_{TS} = maximum allowable stress for simple tension, in lbf/in.², as given in Table 5-1,
- S_{CS} = maximum allowable longitudinal compressive stress, in lbf/in.², for a cylindrical wall acted upon by an axial load with neither a tensile nor a compressive force acting concurrently in a circumfer-

ential direction (determined in accordance with 5.5.4.2 for the thickness-to-radius ratio involved),

- s_{ta} = allowable tensile stress, in lbf/in.²; s_{ta} lower than S_{TS} because of the presence of a coexistent compressive stress perpendicular to it,
- s_{ca} = allowable compressive stress, in lbf/in.²; s_{ca} is lower than S_{CS} because of the presence of a coexistent tensile or compressive stress perpendicular to it,
- s_{tc} = computed tensile stress, in lbf/in.², at the point under consideration,
- s_{cc} = computed compressive stress, in lbf/in.², at the point under consideration,
- s_t = general variable for indicating a tensile stress, in lbf/in.², which may be either an allowable or computed value depending on the context in which the variable is used,
- s_c = general variable for indicating a compressive stress, in lbf/in.², which may be either an allowable or computed value depending on the context in which the variable is used,
- N = ratio of the tensile stress, s_t , to the maximum allowable stress for simple tension, S_{TS} ,
- M = ratio of the compressive stress s_c , to the maximum allowable compressive stress, S_{CS} (see Figure F-1).

5.5.2.2 The term tank wall is defined in 3.3. Unless otherwise stipulated in this standard, the stresses in nozzle and manway necks, reinforcing pads, flanges, and cover plates shall not exceed the values that apply for the walls of the tank. | 02

5.5.3 Maximum Tensile Stresses

5.5.3.1 The maximum tensile stresses in the outside walls of a tank, as determined for any of the loadings listed in 5.4 or any concurrent combination of such loadings that is expected to be encountered in the specified operation, shall not exceed the applicable stress values determined in accordance with provisions described in 5.5.3.2 and 5.5.3.3.

5.5.3.2 If both the meridional and latitudinal unit forces, T_1 and T_2 , are tensile or if one force is tensile and the other is zero, the computed tensile stress, S_{TS} , shall not exceed the applicable value given in Table 5-1.

5.5.3.3 If the meridional force, T_1 , is tensile and the coexistent latitudinal unit force, T_2 , is compressive or if T_2 is tensile and T_1 is compressive, the computed tensile stress, s_{tc} , shall not exceed a value of the allowable tensile stress, s_{ta} , obtained by multiplying the applicable stress value given in Table 5-1 by the appropriate value of N obtained from Figure 5-1 for the value of compressive stress ($s_c = s_{cc}$) and the co-

¹⁵See Biaxial Stress Criteria for Large Low-Pressure Tanks, written by J. J. Dvorak and R.V. McGrath and published as Bulletin No. 69 (June 1961) by the Welding Research Council, 345 East 47th Street, New York, New York 10017.

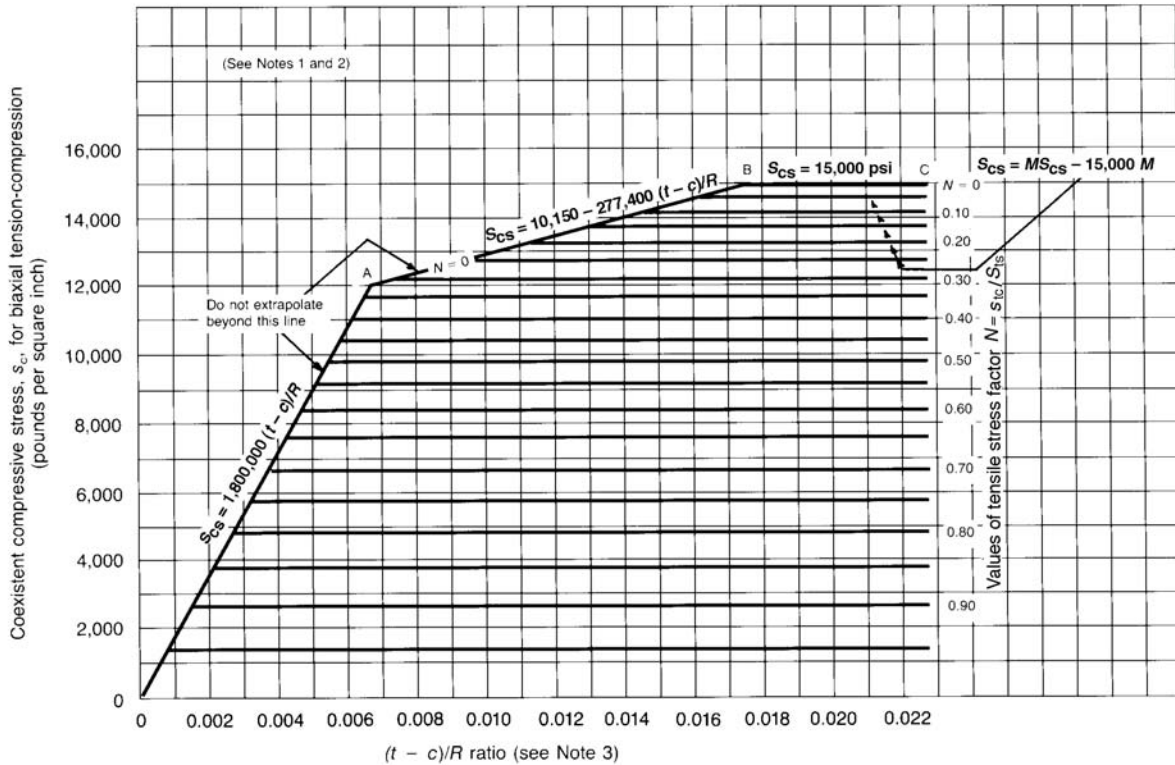

Notes:

1. At no time can a compressive stress for a particular value of $(t - c)/R$ exceed S_{cs} , represented by curve 0ABC; no values of compressive stress or N are permitted to fall to the left or above this curve.
2. See Figure F-1 for relationship between factors M and N .
3. If compressive stress is latitudinal, use $R = R_1$; if compressive stress is meridional, use $R = R_2$.

Figure 5-1—Biaxial Stress Chart for Combined Tension and Compression, 30,000–38,000 lbf/in.² Yield Strength Steels 104

related ratio of $(t - c)/R$ involved. However, in cases where the unit force acting in compression does not exceed 5% of the coexistent tensile unit force acting perpendicular to it, the designer has the option of permitting a tensile stress of the magnitude specified in 5.5.3.2 instead of complying strictly with the provisions of this paragraph, (see F.1 for examples illustrating the determination of allowable tensile stress values, s_{ta} , in accordance with this paragraph). In no event shall the value of s_{ta} exceed the product of the applicable joint efficiency for tension as given in Table 5-2 and the allowable stress for simple tension shown in Table 5-1.

5.5.4 Maximum Compressive Stresses

5.5.4.1 Except as provided in 5.12.4.3 for the compression-ring region, the maximum compressive stresses in the outside walls of a tank, as determined for any of the loadings listed in 5.4 or any concurrent combination of loadings expected to be encountered in the specified operation, shall not exceed the applicable stress values determined in accordance with the provisions described in 5.5.4.2 through 5.5.4.8. These rules do not purport to apply when the circumferential stress on a cylindrical wall is compressive (as in a cylinder acted upon by external pressure). However,

values of S_{cs} computed as in 5.5.4.2, with R equal R_1 when the compressive unit force is latitudinal or to R_2 when the compressive unit force is meridional, in some degree form the basis for the rules given in 5.5.4.3, 5.5.4.4, and 5.5.4.5, which apply to walls of double curvature.

5.5.4.2 If a cylindrical wall, or a portion thereof, is acted upon by a longitudinal compressive force with neither a tensile nor a compressive force acting concurrently in a circumferential direction, the computed compressive stress, s_{cs} , shall not exceed a value, S_{cs} , established for the applicable thickness-to-radius ratio as follows:

For values of $(t - c)/R$ less than 0.00667,

$$S_{cs} = 1,800,000[(t - c)/R]$$

For values of $(t - c)/R$ between 0.00667 and 0.0175,

$$S_{cs} = 10,150 + 277,400[(t - c)/R]$$

For values of $(t - c)/R$ greater than 0.0175,

$$S_{cs} = 15,000$$

Table 5-1—Maximum Allowable Stress Values for Simple Tension

Specification (See Note 1)	Grade	Notes	Specified Minimum		Maximum Allowable Tensile Stress for S_{TS} ($\text{lb}/\text{in.}^2$, see Notes 2 and 3)
			Tensile Strength ($\text{lb}/\text{in.}^2$)	Yield Point ($\text{lb}/\text{in.}^2$)	
Plates					
ASTM A 36	—	4	58,000	36,000	16,000
ASTM A 131	A	4, 5 and 6	58,000	34,000	15,200
ASTM A 131	B	4	58,000	34,000	16,000
ASTM A 131	CS	4	58,000	34,000	16,000
ASTM A 283	C	4 and 5	55,000	30,000	15,200
ASTM A 283	D	4, 5 and 6	60,000	33,000	15,200
ASTM A 285	C	5	55,000	30,000	16,500
ASTM A 516	55	—	55,000	30,000	16,500
ASTM A 516	60	—	60,000	32,000	18,000
ASTM A 516	65	—	65,000	35,000	19,500
ASTM A 516	70	—	70,000	38,000	21,000
ASTM A 537	Class 1	7	70,000	50,000	21,000
ASTM A 537	Class 2	7	80,000	60,000	24,000
ASTM A 573	58	4	58,000	32,000	16,000
ASTM A 573	65	4	65,000	35,000	18,000
ASTM A 573	70	4	70,000	42,000	19,300
ASTM A 633	C and D	4 and 7	70,000	50,000	19,300
ASTM A 662	B	—	65,000	40,000	19,500
ASTM A 662	C	7	70,000	43,000	21,000
ASTM A 678	A	4 and 8	70,000	50,000	19,300
ASTM A 678	B	4 and 7	80,000	60,000	22,100
ASTM A 737	B	7	70,000	50,000	21,000
ASTM A 841	Class 1	7	70,000	50,000	21,000
CSA G40.21	38W and 38WT	4	60,000	38,000	16,500
CSA G40.21	44W and 44WT	4	65,000	44,000	18,000
CSA G40.21	50W	4	65,000	50,000	18,000
CSA G40.21	50WT	4	70,000	50,000	19,300
ISO 630	E275 Quality C, D	4	59,500	37,000	16,400
ISO 630	E355 Quality C, D	4	71,000	48,500	19,600
Pipe					
Seamless					
API Spec 5L	B	—	60,000	35,000	18,000
ASTM A 33	B	—	60,000	35,000	18,000
ASTM A 106	B	—	60,000	35,000	18,000
ASTM A 106	C	—	70,000	40,000	21,000
ASTM A 333	1	—	55,000	30,000	16,500
ASTM A 333	3	—	65,000	35,000	19,500
ASTM A 333	6	—	60,000	35,000	18,000
ASTM A 524	I	—	60,000	35,000	18,000
ASTM A 524	II	—	55,000	30,000	16,500
Electric-Fusion Welded					
ASTM A 134	A 283 Grade C	4, 5 and 9	55,000	30,000	12,100
ASTM A 134	A 285 Grade C	5 and 9	55,000	30,000	13,200
ASTM A 139	B	9	60,000	35,000	14,400
ASTM A 671	CA55	9	55,000	30,000	13,200
ASTM A 671	CC60	9	60,000	32,000	14,400
ASTM A 671	CC65	9	65,000	35,000	15,600
ASTM A 671	CC70	9	70,000	38,000	16,800
ASTM A 671	CD70	7 and 9	70,000	50,000	16,800
ASTM A 671	CD80	7 and 9	80,000	60,000	19,200
ASTM A 671	CE55	9	55,000	30,000	13,200
ASTM A 671	CE60	9	60,000	32,000	14,400

Table 5-1—Maximum Allowable Stress Values for Simple Tension (Continued)

Specification (See Note 1)	Grade	Notes	Specified Minimum		Maximum Allowable Tensile Stress for Tension, S_{TS} (lbf/in. ² , see Notes 2 and 3)
			Tensile Strength (lbf/in. ²)	Yield Point (lbf/in. ²)	
Forgings					
ASTM A 105	—	—	60,000	30,000	18,000
ASTM A 181	I	—	60,000	30,000	18,000
ASTM A 181	II	—	70,000	36,000	21,000
ASTM A 350	LF1	—	60,000	30,000	18,000
ASTM A 350	LF2	—	70,000	36,000	21,000
ASTM A 350	LF3	—	70,000	40,000	21,000
Castings and bolting					
ASTM A 27	60-30	10	60,000	30,000	14,400
ASTM A 36	For anchor bolting	11	58,000	36,000	15,300
ASTM A 193	B7	11	125,000	105,000	24,000
ASTM A 307	B for flanges and pressure parts	11 and 12	55,000	—	8,400
ASTM A 307	B for structural parts and anchor bolting	11	55,000	—	15,000
ASTM A 320	L7	11	125,000	105,000	24,000
Structural shapes Resisting Internal Pressure					
ASTM A 36	—	4 and 6	58,000	36,000	15,200
ASTM A 131	A	4 and 6	58,000	34,000	15,200
ASTM A 633	A	4	63,000	42,000	17,400
ASTM A 992	—	4 and 6	65,000	50,000	15,200
CSA G40.21	38W and 38WT	4 and 6	60,000	38,000	15,200
CSA G40.21	44W and 44WT	4 and 6	65,000	44,000	15,200
CSA G40.21	50W	4 and 6	65,000	50,000	15,200
CSA G40.21	50WT	4 and 6	70,000	50,000	15,200

Notes:

- All pertinent modifications and limitations of specifications required by 4.2. through 4.6 shall be complied with.
- Except for those cases where additional factors or limitations are applied as indicated by references to Notes 4, 6, 10 and 12, the allowable tensile stress values given in this table for materials other than bolting steel are the lesser of (a) 30% of the specified minimum ultimate tensile strength for the material or (b) 60% of the specified minimum yield point.
- Except when a joint efficiency factor is already reflected in the specified allowable stress value, as indicated by the references to Note 10, or where the value of N determined in accordance with 5.5.3.3. is less than the applicable joint efficiency given in Table 5-2 (and therefore effects a greater reduction in allowable stress than would the pertinent joint efficiency factor, if applied), the specified stress values for welds in tension shall be multiplied by the applicable joint efficiency factor, E , given in Table 5-2.
- Stress values for structural quality steels include a quality factor of 0.92.
- Plates and pipe shall not be used in thickness greater than $\frac{3}{4}$ in.
- Stress values are limited to those for steel that has an ultimate tensile strength of only 55,000 lbf/in.².
- Less than or equal to $2\frac{1}{2}$ in. thickness.
- Less than or equal to $1\frac{1}{2}$ in. thickness.
- Stress values for fusion-welded pipe include a welded-joint efficiency factor of 0.80 (see 5.23.3). Only straight-seam pipe shall be used; the use of spiral-seam pipe is prohibited.
- Stress values for castings include a quality factor of 0.80.
- See 5.6.
- Allowable stress based on Section VIII of the *ASME Boiler and Pressure Vessel Code* multiplied by the ratio of the design stress factors in this standard and Section V111 of the *ASME Code*, namely 0.30/0.25.

02

04

04

04

5.5.4.3 If both the meridional and latitudinal unit forces, T_1 and T_2 , are compressive and of equal magnitude, the computed compressive stress, s_{cc} , shall not exceed a value, s_{ca} , established for the applicable thickness-to-radius ratio as follows:

For values of $(t - c)/R$ less than 0.00667,

$$S_{ca} = 1,000,000[(t - c)/R]$$

For values of $(t - c)/R$ between 0.00667 and 0.0175,

$$S_{ca} = 5650 + 154,200[(t - c)/R]$$

For values of $(t - c)/R$ greater than 0.0175,

$$S_{ca} = 8340$$

5.5.4.4 If both the meridional and latitudinal unit forces, T_1 and T_2 , are compressive but of unequal magnitude, both the larger and smaller computed compressive stresses shall be limited to values that satisfy the following requirements:

$$(S_1 + 0.8S_s)/S_{cs} \leq 1.0$$

$$1.8S_s/S_{cs} \leq 1.0$$

where

S_1 = larger stress, in lbf/in.²,

S_s = small stress, in lbf/in.²,

S_{cs} = maximum allowable longitudinal compressive stress, in lbf/in.², determined as in 5.5.4.2 using R for the larger unit force in the first equation and for the smaller unit force in the second equation.

Note: In the previous expressions, if the unit force involved is latitudinal, R shall be equal to R_1 ; if the force is meridional, R shall be equal to R_2 .

5.5.4.5 If the meridional unit force, T_1 , is compressive and the coexistent unit force T_2 , is tensile, except as otherwise provided in 5.5.4.6, or if T_2 is compressive and T_1 is tensile the computed compressive stress, s_{cc} , shall not exceed a value of the allowable compressive stress, s_{ca} , determined from Figure 5-1 by entering the computed value of N and the value of t/R associated with the compressive unit stress and reading the value of s_c that corresponds to that point. The value of s_c will be the limiting value of s_{ca} for the given conditions. (See F-1 for examples illustrating the determination of allowable compressive stress values in accordance with this paragraph.)

5.5.4.6 When a local axial compressive buckling stress in a cylindrical shell is primarily due to a moment in the cylinder, then the allowable longitudinal compressive stress S_{cs} or S_{ca} , as specified in 5.5.4.2 or 5.5.4.3, may be increased by 20%. If the shell bending is due to wind (tank full or empty) or due to earthquake (tank empty), then in addition to the above allowed 20% increase, the allowable buckling stress due to a moment can be increased an additional $1/3$. For tanks full or partially full of liquid and for an earthquake induced longitudinal compressive stress, the allowable compression stress need not be limited for biaxial stress as otherwise may be required by Figure 5-1.

For seismic design, the tank full is usually the worst case. For wind loading, the tank empty and with internal pressure is usually the worst case for local, bending induced compressive stress.

5.5.4.7 The allowable compressive stresses previously specified in 5.5.4 are predicated on butt-welded construction. If one or more of the main joints across which the compressive force acts are of the lap-welded type, the allowable compressive stress will be determined according to 5.5.4, but the minimum compressive stress shall be subject to the limitations of 5.12.2 and Table 5-2 (including Note 2). | 04

5.5.4.8 Cylindrical shells can be checked for wind buckling to determine if there is the need for intermediate wind girders using the rules of 5.10.6. If the transition between the roof or bottom is a curved knuckle section (5.12.3) then $1/3$ of the knuckle height shall be included as part of the unstiffened shell height. | 04

5.5.5 Maximum Shearing Stresses

The maximum shearing stresses in welds used for attaching manways and nozzles and their reinforcements or other attachments to the walls of a tank and in sections of manway or nozzle necks that serve as reinforcement attachment shall not exceed 80% of the value of the applicable maximum allowable tensile stress, S_{ts} , given in Table 5-1 for the kind of material involved. Such maximum shearing stresses are permissible only where the loading is applied in a direction perpendicular to the length of the weld and must be reduced where the loading is applied differently (see 5.16.8.3).

5.5.6 Maximum Allowable Stresses for Wind or Earthquake Loadings

The maximum allowable stresses for design loadings combined with wind or earthquake loadings shall not exceed 133% of the stress permitted for the design loading condition; except as allowed in Appendix L, this stress shall not exceed 80% of the specified minimum yield strength for carbon steel. For stainless steel and aluminum, see Q.3.3.5.

Table 5-2—Maximum Allowable Efficiencies for Arc-Welded Joints

Type of Joint	Limitations	Basic Joint Efficiency (%)	Radiographed (See Note 1)	Maximum Joint Efficiency (%; see Note 2)
Butt joints, attained by double-welding or other means approved by the purchaser, that will obtain the quality of deposited weld metal on the inside and outside weld surfaces that agrees with the requirements of Paragraph UW-35 in Section VIII of the ASME Code; welds using metal backing strips that remain in place are excluded.	None, for all double-welded joints, except for roofs above liquid level.	85	Spot Full (see Note 3)	85 100
	Roofs above liquid level.	70	— Spot Full (see Note 3)	70 85 100
Single-welded butt joint with backing strip or equivalent other than those included above.	Longitudinal or meridional circumference or latitudinal joints between plates not more than 1 1/4 in. thick; nozzle attachment welding without thickness limitation.	75	Spot Full (see Note 3)	75 85
	Roofs above liquid level.	70	— Spot Full (see Note 3)	70 75 85
Single-welded butt joint without backing strip.	Nozzle attachment welding.	70	—	70
Double full-fillet lap joint (see Note 4).	Longitudinal or meridional joints and equivalent (see Note 5) circumferential or latitudinal joints between plates not more than 3/8 in. thick; joints of this type shall not be used for longitudinal or meridional joints that the provisions of 5.12.2 require to be butt-welded.	70	—	70
Single full-fillet lap joint (see Note 4).	Other circumferential or latitudinal joints between plates not more than 5/8 in. thick.	65	—	65
	Longitudinal or meridional joints and circumferential or latitudinal joints between plates not more than 3/8 in. thick; joints of this type shall not be used for longitudinal or meridional joints that the provisions of 5.12.2 require when the thinner plate joined exceeds 1/4 in.	35	—	35
Single full-fillet lap joints for head-to-nozzle joints	For attachment of heads convex to pressure not more than 5/8 in. required thickness, only with use of the fillet weld on the inside of the nozzle.	35	—	35
Nozzle-attachment fillet welds	Attachment welding for nozzles and their reinforcements.		(Included in the strength factors in 5.16.8.3)	
Plug welds (see 5.24.5)	Attachment welding for nozzle reinforcements (see Note 6).	80	—	80

Notes:

- See 5.26 and 7.15 for examination requirements.
- Regardless of any values given in this column, the efficiency for lap-welded joints between plates with surfaces of double curvature that have a compressive stress across the joint from a negative value of P_g or other external loading may be taken as unity; such compressive stress shall not exceed 700 lbf/in.². For all other lap-welded joints, the joint efficiency factor must be applied to the allowable compressive stress, S_{ca} . The efficiency for full-penetration butt-welded joints, which are in compression across the entire thickness of the connected plates, may be taken as unity.
- All main butt-welded joints (see 5.26.4.2) shall be completely radiographed or ultrasonically examined as specified in 5.26 and nozzle and reinforcement attachment welding shall be examined by the magnetic-particle method as specified in 7.15.2.
- Thickness limitations do not apply to flat bottoms supported uniformly on a foundation.
- For the purposes of this table, a circumferential or latitudinal joints shall be considered subject to the same requirements and limitations as are longitudinal or meridional joints when such a circumferential or latitudinal joint is located (a) in a spherical, tori spherical or ellipsoidal shape or in any other surface of double curvature, (b) at the junction between a conical or dished roof (or bottom) and cylindrical sidewalls, as considered in 5.12.3 or (c) at a similar juncture at either end of a transition section or reducer as shown in Figure 5-9.
- The efficiency factors shown for fillet welds and plug welds are not to be applied to the allowable shearing stress values shown in Table 5-3 for structural welds.

5.6 MAXIMUM ALLOWABLE STRESS VALUES FOR STRUCTURAL MEMBERS AND BOLTS

5.6.1 Subject to the provisions of 5.6.5, the maximum stresses in internal or external diaphragms, webs, trusses, columns, and other framing, as determined for any of the loadings listed in 5.4 or any concurrent combination of such loadings expected to be encountered in the specified operation, shall not exceed the applicable allowable stresses given in Table 5-3.

5.6.2 The slenderness ratio (that is, the ratio of the unbraced length, l , to the least radius of gyration, r) for structural members in compression and for tension members other than rods shall not exceed the following values, except as provided in 5.6.3:

- a. For main compression members—120.
- b. For bracing and other secondary members in compression—200.
- c. For main tension members—240.
- d. For bracing and other secondary members in tension—300.

5.6.3 The slenderness ratio of main compression members inside a tank may exceed 120 but not 200, provided that the member is not ordinarily subject to shock or vibration loads and that the unit stress under full design loadings does not exceed the following fraction of the stress value stipulated in Table 5-3 for the member's actual l/r ratio: $f = 1.6 - (l/200r)$.

5.6.4 The gross and net sections of structural members shall be determined as described in 5.6.4.1 through 5.6.4.5.

5.6.4.1 The gross section of a member at any point shall be determined by summing the products of the thickness and the gross width of each element as measured normal to the axis of the member. The net section shall be determined by substituting for the gross width the net width which, in the case of a member that has a chain of holes extending across it in any diagonal or zigzag line, shall be computed by deducting from the gross width the sum of the diameters of all holes in the chain and adding the following quantity for each gauge space in the chain:

$$\frac{s^2}{4g}$$

where

- s = longitudinal spacing (pitch), in in., of any two successive holes,
- g = transverse spacing (gauge), in in., of the same two holes.

5.6.4.2 In the case of angles, the gauge for holes in opposite legs shall be the sum of the gauges from the back of the angle minus the thickness. | 04

5.6.4.3 In determining the net section across plug or slot welds, the weld metal shall not be considered as adding the net area. | 04

5.6.4.4 For splice members, the thickness considered shall be only that part of the thickness of the member that has been developed by the welds or other attachments beyond the section considered. | 04

5.6.4.5 In pin-connected tension members other than forged eyebars, the net section across the pinhole, transverse to the axis of the member, shall be not less than 135%; the net section beyond the pinhole, parallel to the axis of the member, shall be not less than 90% of the net section of the body of the member. The net width of a pin-connected member across the pinhole, transverse to the axis of the member, shall not exceed eight times the thickness of the member at the pin unless lateral buckling is prevented. | 04

5.6.5 External structural, or tubular, columns and framing subject to stresses produced by combination of wind and other applicable loads specified in 5.4 may be proportioned for unit stresses 25% greater than those specified in Table 5-3 if the required section is not less than that required for all other applicable loads combined on the basis of the unit stresses specified in Table 5-3. A corresponding increase may be applied to the allowable unit stresses in the connection bolts or welds for such members. | 04

5.6.6 Allowable design stresses for bolts are established that recognize possible stressing during initial tightening. For flange bolts, these design allowable stresses also recognize additional stressing during overload and testing. Where bolts are used as anchorage to resist the shell uplift, see 5.11.2.3 for allowable stresses. | 04

5.7 CORROSION ALLOWANCE

When corrosion is expected on any part of the tank wall or on any external or internal supporting or bracing members upon which the safety of the completed tank depends, additional metal thickness in excess of that required by the design computations shall be provided, or some satisfactory method of protecting these surfaces from corrosion shall be employed. The added thickness need not be the same for all zones of exposure inside and outside the tank (see Appendix G).

5.8 LININGS

When corrosion-resistant linings are attached to any element of the tank wall, including nozzles, their thickness shall not be included in the computation for the required wall thickness.

Table 5-3—Maximum Allowable Stress Values for Structural Members

Structural Member	Value for Members Not Subject to Pressure-Imposed Loads (lbf/in. ²)	Value for Members Subject to Pressure-Imposed Loads (lbf/in. ²)
Tension		
Rolled steel, on net section	18,000	Per Table 5-1
Butt welds on smaller cross-sectional area, in or at edge of weld (see 5.16.8.3, item a)	18,000	Per Table 5-1
Bolts and other threaded parts on net area at roof of thread	18,000	Per Table 5-1
Compression (see Note 1)		
Axially loaded structural columns, structural bracing, and structural secondary members, on gross section	$18,000/[1 + (l^2/18,000r^2)]$ but not to exceed 15,000	$18,000/[1 + (l^2/18,000r^2)]$ but not to exceed 15,000
Axially Loaded tubular columns, tubular bracing and tubular secondary members, on gross section (minimum permissible thickness of 1/4 in.)	$18,000Y/[1 + (l^2/18,000r^2)]$ but not to exceed 15,000Y	$18,000Y/[1 + (l^2/18,000r^2)]$ but not to exceed 15,000Y
Butt welds on smaller cross-sectional area, in or at edge of weld (crushing)	18,000	15,000
Plate-girder stiffeners, on gross section	18,000	15,000
Bending (see Note 2)		
Tension on extreme fibres of rolled sections, plate girders, and built-up members	18,000	Per Table 5-1
Compression on extreme fibers of rolled sections, plate girders, and built-up members		
With ld/bt not in excess of 600	18,000	Same as tens. val. from Table 5-1
With ld/bt in excess of 600	$10,800,000/(ld/bt)$	$[(600) \text{ (tension value from Table 5-1)}]/[(ld/bt)]$
Stress on extreme fibers of pins	27,000	20,000
Members subjected to both axial and bending loads shall be proportioned so that maximum combined axial and bending stress will not exceed the permissible value for axial loading alone		
Stresses on extreme fibers of butt welds resulting from bending shall not exceed the values prescribed for tension and compression, respectively; such values for welds in tension must be multiplied by the applicable joint efficiency		
Stresses on extreme fibers of butt welds resulting from bending shall not exceed the values prescribed for tension and compression, respectively; such values for welds in tension must be multiplied by the applicable joint efficiency		

Table 5-3—Maximum Allowable Stress Values for Structural Members (Continued)

Structural Member	Value for Members Not Subject to Pressure-Imposed Loads (lbf/in. ²)	Value for Members Subject to Pressure-Imposed Loads (lbf/in. ²)
	Shearing (see Note 2)	
Pins and turned bolts in reamed or drilled holes	13,500	12,000
Unfinished bolts	10,000	8,000
Webs of beams and plate girders where h/t is not more than 60, or where web is adequately stiffened, on gross section of web	12,000	$2/3$ tension value from Table 5-1
Webs of beams and plate finders where web is not adequately stiffened and h/t is more than 60, on gross section of web	$18,000/[1 + (h^2/7200t^2)]$	(Tension value from Table 5-1) $/[1 + (h^2/7200t^2)]$
Fillet welds where load is perpendicular to the length of weld, on the section through the throat (see 5.16.8.3, item b)	12,600	70% tension value from Table 5-1
Fillet welds where load is parallel to the length of weld, on the section through the throat (see 5.16.8.3, item b)	9,000	50% tension value from Table 5-1
Plug welds or slot welds, on effective faying-surface area of weld (see 5.24.5 and Table 5-2)	11,700	65% tension value from Table 5-1
Butt welds on least cross-sectional area, in or at edge of weld (see 5.16.8.3, item a)	14,400	80% tension value from Table 5-1
	Bearing	
Pins and turned bolts in reamed or drilled holes	24,400	$1.33 \times$ tension value from Table 5-1
Load applied to bolt at only one side of the member connected		
Load distributed uniformly, approximately, across thickness of the member connected	30,000	$1.67 \times$ tension value from Table 5-1
Unfinished bolts		
Load applied to bolt at only one side of the member connected	16,000	$0.09 \times$ tension value from Table 5-1
Load distributed uniformly, approximately, across thickness of the member connected	20,000	$1.1 \times$ tension value from Table 5-1

Notes:

- The variables in the compressive stress equations are defined as follows:
 l = unbraced length of the column, in in.; r = corresponding least radius of gyration of the column, in in.; t = thickness of the tubular column, in in.; Y = unity (1.0) for values of t/R equal to or greater than 0.015; $Y = (2/3)[100(t/r)] \{2-(2/3)[100(t/r)]\}$ for values of t/R less than 0.15.
- The variables in the bending stress equations are defined as follows: l = unsupported length of the member; for a cantilever beam not fully stayed at its outer end against translation or rotation, l shall be taken as twice the length of the compression flange, in in.; d = depth of the member, in in.; b = width of its compression flange, in in.; t = thickness of its compression flange, in in.
- The variables in the shearing stress equations are defined as follows: h = clear distance between web flanges, in in.; t = thickness of the web, in in.

5.9 PROCEDURE FOR DESIGNING TANK WALLS**5.9.1 Free-Body Analysis**

Free-body analysis denotes a design procedure that determines the magnitude and direction of the forces that must be exerted by the walls of a tank, at the level selected for analysis, to hold in static equilibrium the portion of the tank and its contents above or below the selected level as a free-body, as if it were isolated from the remaining portions of the tank by a horizontal plane cutting the walls of the tank at the level under consideration.

5.9.2 Levels of Analysis

Free-body analyses shall be made at successive levels from the top to the bottom of the tank for the purpose of determining the magnitude and character of the meridional and longitudinal unit forces that will exist in the walls of the tank at critical levels under all the various combinations of gas pressure (or partial vacuum) and liquid head to be encountered in service, which may have a controlling effect on the design. Several analyses may be necessary at a given level of the tank to establish the governing conditions of gas

pressure and liquid head for that level. The thicknesses required in the main walls of the tank shall then be computed by the applicable procedures given in 5.10.3.

5.9.3 Tank Shape and Capacity

The analyses in 5.9.2 provide the exact shape and overall dimensions needed for the desired capacity of the tank. Except for the more common shapes such as spheres and cylinders, the determination of optimum shapes and sizes is frequently a trial-and-error procedure requiring considerable experience and judgment. As a further preliminary to making the free-body analyses (see 5.9.2) of tanks that will be provided with internal ties, diaphragms, trusses, or other members subject to pressure-imposed loads, studies must be made to establish the preferred arrangement of the members and the magnitude and nature of the loads they must carry under the various conditions of gas pressure and liquid level that will be encountered in operation (see 5.13).

5.9.4 Flat Bottoms of Cylindrical Tanks

5.9.4.1 Flat bottoms of cylindrical tanks that are uniformly supported on a ringwall, grade, or concrete-slab foundation are pressure-resisting membranes but are considered non-stressed because of support from the foundation.

5.9.4.2 All bottom plates shall have a minimum nominal thickness of $1/4$ in. exclusive of any corrosion allowance specified by the purchaser for the bottom plate. (See Q.3.4.7 for an exception to this requirement.)

5.9.4.3 Bottom plates shall be ordered to a sufficient size so that when they are trimmed, at least a 1 in. width will project beyond the outside edge of the weld that attaches the bottom to the sidewall plate.

5.9.4.4 Unless otherwise specified by the purchaser, lap-welded bottom plates shall be furnished and installed to lap over the adjacent plate a minimum of 1 in. Three-plate joints in tank bottoms shall not be closer than 12 in. from each other and 12 in. from the sidewall.

5.9.4.5 Lap-welded bottom plates under the sidewall shall have the outer ends of the joints fitted and lap-welded to form a smooth bearing for the sidewall plates (see Figure 5-2).

5.9.4.6 Bottom plates under the sidewall that are thicker than $3/8$ in. shall be butt-welded. The butt-welds shall be made using a backing strip $1/8$ in. thick or more, or they shall be butt-welded from both sides. Welds shall be full fusion through the thickness of the bottom plate. The butt-weld shall extend at least 24 in. inside the sidewall.

5.9.5 Sidewall-to-Bottom Fillet Weld

5.9.5.1 For bottom and annular plate nominal thicknesses $1/2$ in. and less, the attachment between the bottom edge of the lowest course sidewall plate and the bottom plate shall be

a continuous fillet weld laid on each side of the sidewall plate. The size of each weld shall not be greater than $1/2$ in., not less than the nominal thickness of the thinner of the two plates joined (that is, the sidewall plate or the bottom plate immediately under the sidewall), and not less than the values shown in Table 5-4.

5.9.5.2 The plates of the first sidewall course shall be attached to the bottom plates under the sidewall by a fillet weld inside and outside as required by 5.9.5.1, but when the sidewall material has a specified minimum yield strength greater than 36,000 lbf/in.², each weld shall be made with a minimum of two passes.

5.9.5.3 For bottom plates under the sidewall with a nominal thickness greater than $1/2$ in., the attachment welds shall be sized so that either the legs of the fillet welds or the groove depth plus the leg of the fillet for a combined weld are of a size equivalent to the thickness of the bottom plate under the sidewall (see Figure 5-3).

5.9.6 Discontinuity of Junctures

For tanks that have points of marked discontinuity in the direction of the meridional tangent, such as the points that occur at the juncture between a conical or dished roof (or bottom) and a cylindrical sidewall or at the juncture between a conical reducer and a cylindrical sidewall, the portions of the tank near these points shall be designed in accordance with the provisions of 5.12.

5.10 DESIGN OF SIDEWALLS, ROOFS, AND BOTTOMS

5.10.1 Nomenclature

The variables used in the formulas throughout 5.10 are defined as follows:

- P = total pressure, in lbf/in.² gauge, acting at a given level of the tank under a particular condition of loading,

$$= P_1 + P_g,$$
- P_1 = pressure, in lbf/in.² gauge, resulting from the liquid head at the level under consideration in the tank,
- P_g = gas pressure, in lbf/in.² gauge, above the surface of the liquid. The maximum gas pressure (not exceeding 15 lbf/in.² gauge) is the nominal pressure rating of the tank. P_g is positive except in computations used to investigate the ability of a tank to withstand a partial vacuum; in such computations, its value is negative,
- T_1 = meridional unit force, in lbf/in. of latitudinal arc, in the wall of the tank at the level under consideration. T_1 is positive when in tension,
- T_2 = latitudinal unit force, in lbf/in. of meridional arc, in the wall of the tank at the level under consideration. T_2 is positive when in tension. (In cylindrical sidewalls, the latitudinal unit forces are circumferential unit forces.)

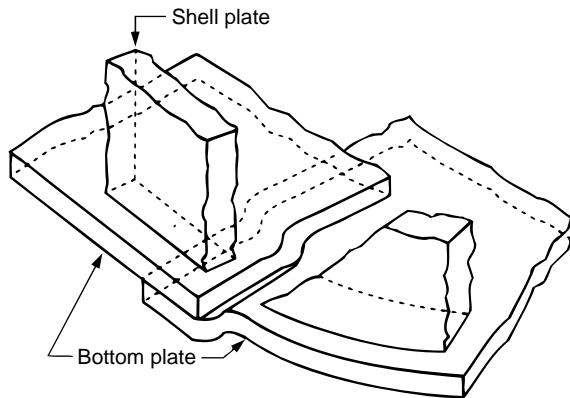

Figure 5-2—Method for Preparing Lap-Welded Bottom Plates Under the Tank Sidewall

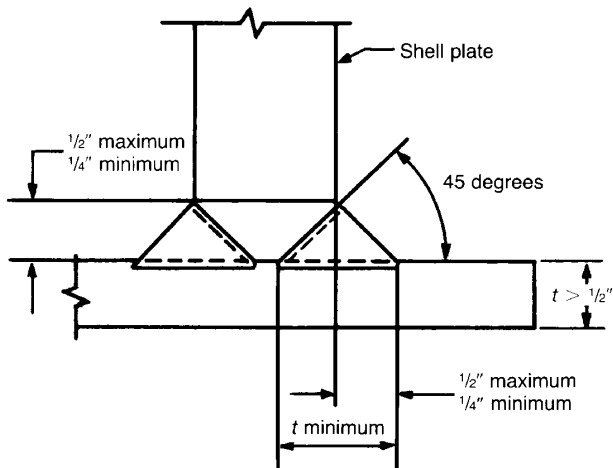

Figure 5-3—Detail of Double Fillet-Groove Weld for Bottom Plates with a Nominal Thickness Greater than 1/2 in. (See 5.9.5.3)

Table 5-4—Sidewall-to-Bottom Fillet Weld for Flat-Bottom Cylindrical Tanks

Maximum Thickness of Shell Plate (in.)	Minimum Size of Fillet Weld (in.)
0.1875	3/16
> 0.1875 – 0.75	1/4
> 0.75 – 1.25	5/16
> 1.25 – 1.50	3/8

R_1 = radius of curvature of the tank wall, in in., in a meridional plane, at the level under consideration. R_1 is to be considered negative when it is on the side of the tank wall opposite from R_2 except as provided in 5.10.2.6,

R_2 = length, in in., of the normal to the tank wall at the level under consideration, measured from the wall of the tank to its axis of revolution. R_2 is always positive except as provided in 5.10.2.6,

W = total weight, in lb, of that portion of the tank and its contents (either above the level under consideration, as in Figure 5-4, panel b, or below it, as in Figure 5-4, panel a) that is treated as a free-body in the computations for that level. Strictly speaking, the total weight would include the weight of all metal, gas, and liquid in the portion of the tank treated as described; however, the gas weight is negligible, and the metal weight may be negligible compared with the liquid weight. W shall be given the same sign as P when it acts in the same direction as the pressure on the horizontal face of the free-body; it shall be given the opposite sign when it acts in the opposite direction,

F = summation, in lb, of the vertical components of the forces in any and all internal or external ties, braces, diaphragms, trusses, columns, skirts, or other structural devices or supports acting on the free-body. F shall be given the same sign as P when it acts in the same direction as the pressure on the horizontal face of the free-body; it shall be given the opposite sign when it acts in the opposite direction,

A_t = cross-sectional area, in in.², of the interior of the tank at the level under consideration,

t = thickness, in in., of the sidewalls, roof, or bottom of the tank, including corrosion allowance,

c = corrosion allowance, in in.,

E = efficiency, expressed as a decimal, of the weakest joint across which the stress under consideration acts.

[Applicable values given in Table 5-2 shall be used except that, for (a) butt-welded joints in compression across their entire thickness and (b) the lap-welded joints in compression specified in Note 3 of Table 5-2, E may be taken as unity.]

S_{ts} = maximum allowable stress for simple tension, in lbf/in.², as given in Table 5-1,

s_{ta} = allowable tensile stress, in lbf/in.², established as prescribed in 5.5.3.3,

s_{ca} = allowable compressive stress, in lbf/in.², established as prescribed in 5.5.4,

s_{tc} = computed tensile stress, in lbf/in.², at the point under consideration,

s_{cc} = computed compressive stress, in lbf/in.², at the point under consideration.

5.10.2 Computation of Unit Forces

5.10.2.1 At each level of the tank selected for free-body analysis as specified in 5.9 (see typical diagrams in Figure 5-4) and for each condition of gas and liquid loading that must be investigated at that level, the magnitude of the meridional and latitudinal unit forces in the wall of the tank shall be computed from the following equations, except as provided in 5.10.2.6, 5.11, or 5.12¹⁶.

$$T_1 = \frac{R_2}{2} \left(P + \frac{W+F}{A_t} \right) \quad (1)$$

$$T_2 = R_2 \left(P - \frac{T_1}{R_1} \right) \quad (2)$$

$$T_2 = R_2 \left[P \left(1 - \frac{R_2}{2R_1} \right) - \frac{R_2}{2R_1} \left(\frac{W+F}{A_t} \right) \right] \quad (3)$$

Note: Footnote 16 is also applicable to Equations 1, 2, and 3.

5.10.2.2 Positive values of T_1 and T_2 indicate tensile forces; negative values indicate compressive forces.

5.10.2.3 Free-body analyses shall be made at the level of each horizontal joint in the sidewalls, roof, and bottom of the tank and at any intermediate levels at which the center of curvature changes significantly. The maximum total pressure (liquid head plus gas pressure) that can exist at a given level will not necessarily be the governing condition for that level. Sufficient analyses shall be made at each level to determine the combination of liquid head and gas pressure (or partial vacuum) that, in conjunction with the allowable tensile and compressive stresses, will control the design at that level. A

¹⁶Equations 2, 5, and 9 have been derived from a summation of the normal-to-surface components of the T_1 and T_2 forces acting on a unit area of the tank wall subjected only to pressure P . To be technically correct, the normal-to-surface components of other loads, such as metal, snow or insulation, should be added to or subtracted from P . For the usual internal design pressure, these added loads are small compared with P and can be mooted without significant error. Where the pressure P is relatively small, as in the case of a partial vacuum loading, the other load components can have a substantial effect on the calculated T_2 force and the resultant thickness.

Equations 3 and 6 are correct only when P is the free-body pressure without the normal-to-surface components of other loads.

The example in F.3 calculates the required roof thicknesses under a small vacuum by considering the metal, insulation and snow loads in Equations 1-5. The designer should note that if these loads had been omitted, the calculated thicknesses would have been much less than the correct values.

In Equations 1, 4, 8, and 10, W is intended to include loads of insignificant value, such as metal weight. At points away from the vertical centerline of the roof, the value of T_2 is required for the thickness calculations of Equations 18, 20, and 22 and the value of P in Equations 2, 5, and 9 must be modified by the normal components of the added loads for the correct determination of T_2 .

tank may normally be operated at a fixed height of liquid contents, but the tank must be made safe for any conditions that might develop in filling or emptying the tank. This will necessitate a particularly careful investigation of sidewalls of double curvature.

5.10.2.4 Mathematically exact instead of approximate values of R_1 and R_2 should be used in computations for ellipsoidal roofs and bottoms. The values for a point at a horizontal distance, x , from the vertical axis of a roof or bottom in which the length of the horizontal semiaxis, a , is two times the length of the vertical semiaxis, b , may be determined by multiplying length a by the appropriate factor selected from Table 5-5. Values for ellipsoidal shapes of other proportions may be computed using the following formulas:

$$R_1 = \frac{b^2}{a^4} \left[\frac{a^4}{b^2} + \left(1 - \frac{a^2}{b^2} \right) x^2 \right]^{1.5} = \frac{b^2 (R_2)^3}{a^4}$$

$$R_2 = \left[\frac{a^4}{b^2} + \left(1 - \frac{a^2}{b^2} \right) x^2 \right]^{0.5}$$

5.10.2.5 Equations 1 and 2 are general formulas applicable to any tank that has a single vertical axis of revolution and to any free-body in the tank that is isolated by a horizontal plane which intersects the walls of the tank in only one circle (see 5.10.2.6). For tanks or segments of tanks of the shapes most commonly used, Equations 1 and 2 reduce to the following simplified equations for the respective shapes indicated in items a-c.

a. For a spherical tank or a spherical segment of a tank, $R_1 = R_2 = R_s$ (the spherical radius of the tank or segment), and Equations 1 and 2 become the following:

$$T_1 = \frac{R_s}{2} \left(P + \frac{W+F}{A_t} \right) \quad (4)$$

$$T_2 = R_s P - T_1 \quad (5)$$

$$T_2 = \frac{R_1}{2} \left(P - \frac{W+F}{A_t} \right) \quad (6)$$

Note: See Footnote 16 for information applicable to Equations 4-6.

Furthermore, if the sphere is for gas pressure only and if $(W+F)/A_t$ is negligible compared with P_g , Equations 4 and 5 reduce to the following:

$$T_1 = T_2 = 1/2 P_g R_s \quad (7)$$

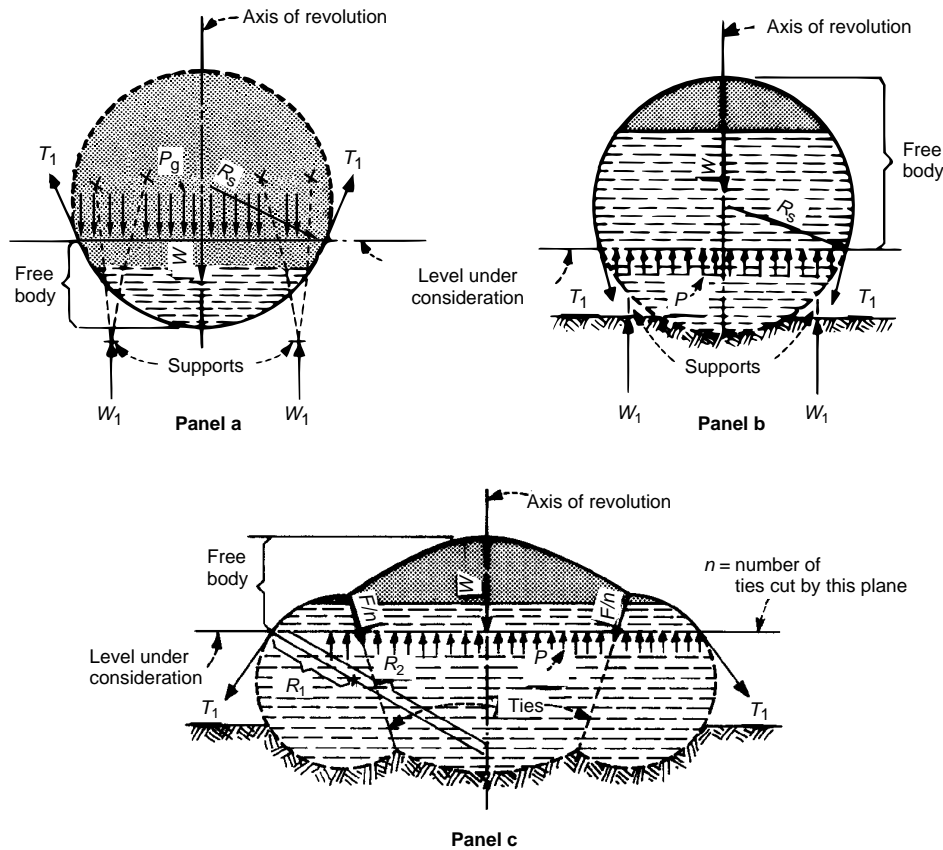

Figure 5-4—Typical Free-Body Diagrams for Certain Shapes of Tanks

b. For a conical roof or bottom,

$$R_1 = \text{infinity}$$

$$R_2 = R_3 / \cos \alpha$$

where

R_3 = horizontal radius of the base of the cone at the level under consideration,

α = one-half the included apex angle of the conical roof or bottom.

For this condition, Equations 1 and 2 reduce to the following:

$$T_1 = \left(\frac{R_3}{2 \cos \alpha} \right) \left(P + \frac{W + F}{A_t} \right) \tag{8}$$

$$T_2 = \frac{PR_3}{\cos \alpha} \tag{9}$$

04 | Note: See Footnote 16 for information applicable to Equations 8 and 9.

c. For cylindrical sidewalls of a vertical tank, $R_1 = \text{infinity}$; $R_2 = R_c$, the radius of the cylinder; and Equations 1 and 2 become the following:

$$T_1 = \left(\frac{R_c}{2} \right) \left(P + \frac{W + F}{A_t} \right) \tag{10}$$

$$T_2 = PR_c \tag{11}$$

Note: See Footnote 16 for information applicable to Equation 10.

04

Furthermore, if the cylinder is for gas pressure only and $(W + F)/A_t$ is negligible compared with P_g , Equations 10 and 11 reduce to the following:

$$T_1 = 1/2 P_g R_c \tag{12}$$

$$T_2 = P_g R_c \tag{13}$$

5.10.2.6 Where a horizontal plane that passes through a tank intersects the roof or bottom in more than one circle, thus isolating more than one free-body at that level, the formulas given in 5.10.2.1 and 5.10.2.5 apply only to the central free-body whose walls continue across and are pierced by the

axis of revolution. (An example of the kind of plane described would be one passed through the bottom of the tank shown in Figure 5-4, panel c, just a short distance below the lower ends of the internal ties.) The meridional and latitudinal unit forces acting along the edges of the annular free-body or bodies lying outside of the central free-body must be computed from formulas developed especially for the particular shape of free-body cross section involved. This standard cannot provide formulas for all shapes of cross sections and conditions of loading that might be used at these locations; however, for a toroidal segment that rests directly on its foundation (see 5.11.1) and has a constant meridional radius, R_1 , such as is used in the outer portion of the bottom of the tanks shown in Figure 5-4, panel c, applicable equations for the meridional and latitudinal unit forces in the walls of the segment are as follows:

$$T_1 = P_g R_1 \left(1 - \frac{R_1}{2R_2} \right) \quad (14)$$

$$T_2 = \frac{1}{2} P_g R_1 \quad (15)$$

The variables are defined in 5.10.1; however, in this case, R_1 is always positive and R_2 is negative when it is on the tank wall on the side opposite from R_1 .

5.10.3 Required Thickness

5.10.3.1 The thickness of the tank wall at any given level shall be not less than the largest value of t as determined for the level by the methods prescribed in 5.10.3.2 through 5.10.3.5. In addition, provision shall be made by means of additional metal, where needed, for the loadings other than internal pressure or possible partial vacuum enumerated in 5.4. If the tank walls have points of marked discontinuity in the direction of the meridional tangent, such as occur at the juncture between a conical or dished roof (or bottom) and a cylindrical sidewall, the portions of the tank near these points shall be designed in accordance with the provisions of 5.12.

5.10.3.2 If the units forces T_1 and T_2 are both positive, indicating tension, for the governing combination of gas pressure (or partial vacuum) and liquid head at a given level of the tank, the larger of the two shall be used for computing the thickness required at that level, as shown in the following equations:

$$t = \frac{T_1}{S_{ts}E} + c \text{ or } t = \frac{T_2}{S_{ts}E} + c \quad (16)$$

In these equations, S_{ts} and E have the applicable values prescribed in Tables 5-1 and 5-2, respectively.

Table 5-5—Factors for Determining Values of R_1 and R_2 for Ellipsoidal Roofs and Bottoms (see 5.10.24)

x/a	$u = R_1/a$	$v = R_2/a$
0.00	2.000	2.000
0.05	1.994	1.998
0.10	1.978	1.993
0.15	1.950	1.983
0.20	1.911	1.970
0.25	1.861	1.953
0.30	1.801	1.931
0.35	1.731	1.906
0.40	1.651	1.876
0.45	1.562	1.842
0.50	1.465	1.803
0.55	1.360	1.759
0.60	1.247	1.709
0.65	1.129	1.653
0.70	1.006	1.591
0.75	0.879	1.521
0.80	0.750	1.442
0.85	0.620	1.354
0.90	0.492	1.253
0.95	0.367	1.137
1.00	0.250	1.000

Note: The variables in this table are defined as follows: x = horizontal distance from point in roof or bottom to the axis of the revolution; a = horizontal semiaxis of the elliptical cross section; $R_1 = ua$; $R_2 = va$.

5.10.3.3 If the unit force T_1 is positive, indicating tension, and T_2 is negative, indicating compression, for the governing combination of gas pressure (or partial vacuum) and liquid head at a given level of the tank or if T_2 is positive and T_1 is negative, the thickness of tank wall required for this condition shall be determined by assuming different thicknesses until one is found for which the simultaneous values of the computed tension stress, s_{tc} , and the computed compressive stress, s_{cc} , satisfy the requirements of 5.5.3.3 and 5.5.4.5, respectively. The determination of this thickness will be facilitated by using a graphical solution such as the one illustrated in F-2.¹⁷ Notwithstanding the foregoing provisions, if the unit force acting in compression in the case described does not exceed 5% of the coexistent tensile unit force acting perpendicular to it, the designer has the option of determining the thickness required for this condition by using the method specified in 5.10.3.2 instead of complying strictly with the provisions of this paragraph. The value of the joint efficiency factor, E , will not enter into this determination unless the

¹⁷See Figure F-3, a copy of a chart used to make graphical solutions.

magnitude of the allowable tensile stress, s_{ta} , is governed by the product ES_{ts} as provided in 5.5.3.3.

5.10.3.4 If the unit forces T_1 and T_2 are both negative and of equal magnitude for the governing condition of loading at a given level of the tank, the thickness of tank wall required for this condition shall be computed using Equation 17:

$$t = \frac{T_1}{S_{ca}} + c = \frac{T_2}{S_{ca}} + c \quad (17)$$

In this equation, S_{ca} has the appropriate value for the thickness-to-radius ratio involved, as prescribed in 5.5.4.3 and 5.5.4.6. Lap-welded joints shall be subject to the limitations of 5.5.4.6 and Table 5-2 (including Note 3).

5.10.3.5 If the unit forces T_1 and T_2 are both negative but of unequal magnitude for the governing condition of loading at a given level, the thickness of tank wall required for this condition shall be the largest of those thickness values, computed by the stepwise procedure outlined in items a–f, that show a proper correlation with the respective thickness-to-radius ratios involved in their computation (see Steps 2 and 4).

a. Step 1. The values of Equations 18 and 19 shall be computed as follows:

$$t = \frac{\sqrt{(T' + 0.8T'')R'}}{1342} + c \quad (18)$$

04 | Note: See Footnote 16 for information applicable to Equation 18.

$$t = \frac{\sqrt{T''R''}}{1000} + c \quad (19)$$

In both equations, the value of T' shall be equal to the larger of the two coexistent unit forces; the value of T'' shall be equal to the smaller of the two unit forces. R' and R'' shall be equal to R_1 and R_2 , respectively, if the larger unit force is latitudinal; conversely, R' and R'' shall be equal to R_2 and R_1 , respectively, if the larger unit force is meridional.

b. Step 2. The corrosion allowance shall be deducted from each of the two thicknesses computed in Step 1, and the thickness-to-radius ratio, $(t - c)/R$, shall be checked for each thickness based on the value of R used in computing it by either Equation 18 or 19. If both such thickness-to-radius ratios are less than 0.00667, the larger of the two thicknesses computed in Step 1 will be the required thickness for the condition under consideration; otherwise, Step 3 shall be followed.

c. Step 3. If one or both thickness-to-radius ratios determined in Step 2 exceed 0.00667, the values of the following equations shall be computed:

$$t = \left(\frac{T' + 0.8T''}{15,000} \right) + c \quad (20)$$

$$t = \frac{T''}{8340} + c \quad (21)$$

Note: See Footnote 16 for information applicable to Equation 20. **04**

d. Step 4. The corrosion allowance shall be deducted from each of the two thicknesses computed in Step 3, and the thickness-to-radius ratio, $(t - c)/R$, shall be checked for each thickness using a value of R equal to R' as defined in Step 1 in connection with the thickness determined from Equation 20 and a value of R equal to R'' in connection with the thickness determined from Equation 21. If both such thickness-to-radius ratios are greater than 0.0175, the larger of the two thicknesses computed in Step 3 will be the required thickness for the condition under consideration; otherwise, Step 5 shall be followed.

e. Step 5. If one or more of the thickness-to-radius ratios determined in Step 2 or Step 4 fall between 0.00667 and 0.0175 and the thickness involved was computed using Equations 18 or 20, a thickness shall be found that satisfies the following equation:

$$\frac{10,150(t - c) + 277,400(t - c)^2}{R'} = T' + 0.8T'' \quad (22)$$

Note: See Footnote 16 for information applicable to Equation 22. **04**

If the thickness involved was computed using Equation 19 or 21, a thickness shall be found that satisfies the following equation:

$$\frac{5650(t - c) + 154,200(t - c)^2}{R''} = T'' \quad (23)$$

f. Step 6. A tentative final selection of thickness shall be made from among the thickness values computed in the previous steps (if the value has not been finally established earlier in the procedure). The values of s_{cc} shall be computed for both T_1 and T_2 and checked to see that they satisfy the requirements of 5.5.4.4 and 5.5.4.6. If the tentative thickness does not satisfy these requirements, the necessary adjustments shall be made in the thickness to make the values of s_{cc} satisfy these requirements. **04**

5.10.3.6 The procedure described in 5.10.3.5 is for the condition in which biaxial compression with unit forces of unequal magnitude is governing. In many cases, however, a tentative thickness will have been previously established by other design conditions and will need to be checked only for

the external pressure or partial vacuum condition. In such cases, the designer has only to compute the values of s_{cc} for both T_1 and T_2 and then check to see that these satisfy the requirements of 5.5.4.4, as specified in Step 6. (See F.3 for examples illustrating the application of 5.10.3.5.)

5.10.4 Least Permissible Thicknesses

5.10.4.1 Tank Wall

The minimum thickness of the tank wall at any level shall be the greatest of the following:

- A measure of $3/16$ in. plus the corrosion allowance.
- The calculated thickness in accordance with 5.10.3 plus the corrosion allowance.
- The nominal thickness as shown in Table 5-6. The nominal thickness refers to the tank shell as constructed. The thicknesses specified are based on erection requirements.

5.10.4.2 Nozzle Neck

See 5.19.2 for the minimum thickness of the nozzle neck.

5.10.5 External Pressure Limitations

5.10.5.1 The thicknesses computed using the formulas and procedures specified in 5.10, where P_g is a negative value equal to the partial vacuum for which the tank is to be designed, will ensure stability against collapse for tank surfaces of double curvature in which the meridional radius, R_1 , is equal to or less than R_2 or does not exceed R_2 by more than a very small amount. Data on the stability of sidewall surfaces of prolate spheroids are lacking; the formulas and procedures are not intended to be used for evaluating the stability of such surfaces or of cylindrical surfaces against external pressure.

5.10.5.2 This standard does not contain provisions for the design of cylindrical sidewalls that are subject to partial internal vacuum in tanks constructed for the storage of gases or vapors alone. However, cylindrical sidewalls of vertical tanks designed in accordance with these rules for storing liquids (with the thickness of upper courses not less than specified in 5.10.4 for the tank size involved and with increasing thickness from top to bottom as required for the combined gas and liquid loadings) may be safely subjected to a partial vacuum in the gas or vapor space not exceeding 1 ounce per square in. with the operating liquid level in the tank at any stage from full to empty. The vacuum relief valve or valves shall be set to open at a smaller partial vacuum so that the 1-ounce partial vacuum will not be exceeded when the inflow of air (or gas) through the valves is at the maximum specified rate.

5.10.6 Intermediate Wind Girders for Cylindrical Sidewalls

5.10.6.1 The maximum height of unstiffened sidewall, in ft, shall not exceed:

$$H_1 = 6(100t) \sqrt{\left(\frac{100t}{D}\right)^3}$$

where

H_1 = vertical distance between the intermediate wind girder and the top of the sidewall or in the case of formed heads the vertical distance between the intermediate wind girder and the head-bend line plus one-third the depth of the formed head, in ft,

t = the thickness of the top sidewall course, as ordered condition unless otherwise specified, in in.,

D = nominal tank diameter, in ft.

Note: This formula is based on the following factors:

a. A design wind velocity, V , of 100 mph which imposes a dynamic pressure of 25.6 lbf/ft². The velocity is increased by 10% for either a height above the ground or a gust factor. The pressure is thus increased to 31 lbf/ft². An additional 5 lbf/ft² is added for internal vacuum. This pressure is intended by these rules to be the result of a 100 miles per hour fastest mile velocity at approximately 30 ft above the ground. H_1 may be modified for other wind velocities, as specified by the purchaser, by multiplying the formula by $(100/V)^2$. When a design wind pressure, rather than a wind velocity, is stated by the purchaser, the preceding increase factors should be added, unless they are contained within the design wind pressure.

b. The formula is based on the wind pressure being uniform over the theoretical buckling mode in the tank sidewall which eliminates the necessity of a shape factor for the wind loading.

c. The formula is based on the modified U.S. Model Basin formula for the critical uniform external pressure on thin-wall tubes free from end loading, subject to the total pressure in item a.

d. When other factors are specified by the purchaser which are greater than those in (a) through (c), the total load on the sidewall shall be modified accordingly and H_1 shall be decreased by the ratio of 36 lbf/ft² to the modified total pressure.

e. The background for the criteria given in the note is covered in R. V. McGrath, "Stability of API Standard 650 Tank Shells," Proceedings of the American Petroleum Institute, Section III—Refining, American Petroleum Institute, New York, 1963, Vol. 43, pp. 458-469.

5.10.6.2 To determine the maximum height H_1 of the unstiffened sidewall, a calculation shall be made using the

Table 5-6—Tank Radius Versus Nominal Plate Thickness

Tank Radius (ft)	Nominal Plate Thickness (in.)
≤ 25	³ / ₁₆
> 25 – 60	¹ / ₄
> 60 – 100	⁵ / ₁₆
> 100	³ / ₈

thickness of the top sidewall course. Next the height of the transformed sidewall shall be calculated as follows:

- a. Change the width (W) of each sidewall course into a transposed width (W_{tr}) of each sidewall course, having the top sidewall thickness, by the following relationship:

$$W_{tr} = W \sqrt{\left(\frac{t_{uniform}}{t_{actual}}\right)^5}$$

where

$t_{uniform}$ = thickness of the top sidewall course, as ordered condition in in.es, unless otherwise specified,

t_{actual} = thickness of the sidewall course for which transposed width is being calculated, as ordered condition in in., unless otherwise specified,

W = actual course width, in ft,

W_{tr} = transposed course width, in ft.

- b. The sum of the transposed width of each course will give the height of the transformed sidewall.

5.10.6.3 If the height of the transposed sidewall is greater than the maximum height, H_1 , an intermediate girder is required.

- a. For equal stability above and below the intermediate wind girder, the latter should be located at the mid-height of the transposed sidewall. The location of the girder on the actual sidewall should be at the same course and relative position as on the transposed sidewall using the foregoing thickness relationship.

- b. Other locations for the girder may be used provided the height of the unstiffened sidewall on the transposed sidewall does not exceed H_1 (see 5.10.6.5).

5.10.6.4 If half the height of the transposed sidewall exceeds the maximum height, H_1 , a second intermediate girder shall be used in order to reduce the height of unstiffened sidewall to a height less than the maximum.

5.10.6.5 Intermediate wind girders shall not be attached to the sidewall within 6 in. of a horizontal joint of the sidewall. When the preliminary location of a girder is within this dis-

tance from a horizontal joint, the girder shall preferably be located 6 in. below the joint, except that the maximum unstiffened sidewall height shall not be exceeded.

5.10.6.6 The required minimum section modulus, in in. cubed, of the intermediate wind girder shall be determined by the equation:

$$Z = 0.0001D^2H_1$$

Note: This equation is based on wind velocity of 100 miles per hour. If specified by the purchaser, other wind velocities may be used by multiplying the equation by $(V/100)^2$. Refer to item a. of notes to 5.10.6.1 for a description of the loads on the tank sidewall which are used for the 100 mile per hour design wind velocity.

5.10.6.7 Where the use of a transposed sidewall permits the intermediate wind girder to be located at a height less than H_1 calculated by the formula in 5.10.6.1, the spacing to the mid-height of the transposed sidewall, transposed to the height of the actual sidewall, may be substituted for H_1 in the calculation for minimum section modulus if the girder is attached at the transposed location.

5.10.6.8 The section modulus of the intermediate wind girder shall be based upon the properties of the attached members and may include a portion of the sidewall for a distance of $1.47(Dt)^{0.5}$ above and below the attachment to the sidewall, where t is the sidewall thickness at the attachment.

5.10.6.9 Intermediate stiffeners extending a maximum of 6 in. from the outside of the sidewall are permitted without need for an opening in the stiffener when the nominal stairway width is at least 24 in. For greater outward extensions of a stiffener, the stairway shall be increased in width to provide a minimum clearance of 18 in. between the outside of the stiffener and the handrail of the stairway, subject to the approval of the purchaser.

If an opening is necessary, the built up section shall have a section modulus greater than or equal to that required for the stiffener.

5.11 SPECIAL CONSIDERATIONS APPLICABLE TO BOTTOMS THAT REST DIRECTLY ON FOUNDATIONS

5.11.1 Shaped Bottom

Where the bottom of a tank is a spherical segment or a spherical segment combined with one or more toroidal segments, or is conical in shape, and the entire bottom area rests directly on the tank foundation in such a way that the foundation will absorb the weight of the tank contents without significant movement, the liquid head may be neglected in computing the internal pressure, P , acting on the bottom and in computing the unit forces, T_1 and T_2 , in the bottom. Under these conditions, the unit forces in the bottom of the tank may be computed considering that P in each case is equal to P_g .

5.11.2 Flat-Bottom Tanks with Counterbalance

5.11.2.1 General

In tanks that have cylindrical sidewalls and flat bottoms, the uplift that results from the pressure acting on the underside of the roof combined with the effect of design wind pressure, or seismic loads if specified, must not exceed the weight of the sidewalls plus the weight of that portion of the roof that is carried by the sidewalls when no uplifts exists unless the excess is counteracted by a counterbalancing structure such as a concrete ringwall, a slab foundation, or another structural system. The means for accomplishing this shall be a matter of agreement between the manufacturer and the purchaser. Similar precautions must be taken with flat-bottomed tanks of other shapes. All weights used in such computations shall be based on net thicknesses of the materials, exclusive of corrosion allowance.

5.11.2.2 Counterbalancing Structure

The counterbalancing structure, which may be a foundation or support system, shall be designed to resist uplift calculated as described in 5.11.2 based on 1.25 times the internal design pressure plus the wind load on the shell and roof based on its projection on a vertical plane. If seismic loads are specified, uplift shall be calculated using internal design pressure plus the seismic loads. Wind and seismic loads need not be combined.

5.11.2.3 Anchorage

The design of the anchorage and the attachments to the tank shall be a matter of agreement between the manufacturer and the purchaser and shall satisfy the following conditions:

- a. The design stresses shall satisfy all of the conditions in Table 5-7.
- b. When corrosion is specified for the anchors, thickness shall be added to the anchors and the attachments. If bolts are used for anchors, the nominal diameter shall be not less than 1 in. plus a corrosion allowance of at least 1/4 in. on the diameter.
- c. Attachments of anchors to the shell shall be designed using good engineering practice.
- d. Anchor materials and allowable stresses shall be those permitted by Table 5-1.

Note: The allowable stresses for stainless steel and aluminum anchors for the applicable loading conditions are found in Q.3.3.5, Q.8.1.3, and Table Q-3.

5.11.3 Flat-Bottom Tanks Without Counterbalancing Weight

The detailed design of flat-bottom tanks without counterbalancing weight shall be a matter of agreement between the manufacturer and the purchaser and shall satisfy the following conditions:

- a. The bottom of a flat-bottom tank shall be designed to remain flat during all design and test conditions. When the flat-bottom tank is designed without anchoring the shell to the counterbalancing weight, the bottom will be designed to carry all the weight and pressure forces distributed on the bottom and to transfer the uplift forces from the sidewall through the bottom plates. The uplift forces will be obtained from a free-body analysis as specified in 5.9 and 5.10. These forces shall be determined for the tank (deducting any specified corrosion allowance) for both a full and an empty condition and shall include uplift from design wind velocity. The largest values will be used for design.
- b. The bottom plates in the flat-bottom tank shall be designed as a strength member to span between main structural members (for example, grillage beams or other structural members) and transfer the distributed pressure and liquid-weight forces to these main structural members.
- c. When the bottom plate is a bending strength member, single-fillet lap joints are not permitted in the bottom plate.
- d. Adequate provision shall be made at the sidewall to transfer the uplift forces from the shell to the shear-carrying elements in the bottom structure.
- e. Consideration shall be given to protecting all bottom structural elements from environmental corrosion.
- f. Anchorage shall be provided for resistance to wind and earthquake forces and shall be designed in accordance with 5.11.2.3.

Table 5-7—Allowable Tension Stresses for Uplift Pressure Conditions (see 5.11.2.2)

Source of Uplift Pressure	Allowable Tension Stress ^a (lbf/in. ²)
Tank design pressure	Allowable design stress, S_{TS} (see Table 5-1)
Tank design pressure plus wind or earthquake	Smaller of $1.33 S_{TS}$ or 80% of the specified minimum yield strength
Tank test pressure	Smaller of $1.33 S_{TS}$ or 80% of the specified minimum yield strength

Note:

^aThe allowable tension stress determined at the minimum net section or tensile stress area of the anchor.

5.11.4 Additional Considerations

Unless otherwise required, tanks that may be subject to sliding due to wind shall use a maximum allowable sliding friction of 0.40 times the force against the tank bottom.

5.12 DESIGN OF ROOF AND BOTTOM KNUCKLE REGIONS AND COMPRESSION-RING GIRDERS

5.12.1 Design Limitations

The design rules in this section do not cover the junction between a conical reducer and cylindrical sidewalls except as indicated on Figure 5-9, panel b. However, the provisions of this section shall be observed at such a juncture if the angle formed is nonreentrant. (See 5.18.3 for design of reentrant junctures.)

5.12.2 General

When the roof or bottom of a pressure tank is a cone or partial sphere (or nearly so) and is attached to cylindrical sidewalls, the membrane stresses in the roof or bottom pull inward on the periphery of the sidewalls. This pull results in circumferential compressive forces at the juncture, which may be resisted either by a knuckle curvature in the roof or bottom or by a limited zone at the juncture of the intersecting roof or bottom plates and sidewall plates, supplemented in some cases by an angle, a rectangular bar, or a horizontally disposed ring girder. All longitudinal and meridional joints in a knuckle region, or between those portions of plates that are considered to participate¹⁸ in resisting compressive forces in a compression-ring region, and all radial joints in a compression-ring angle, bar, or girder shall be butt-welded.

5.12.3 Knuckle Regions

5.12.3.1 If a curved knuckle is provided, a ring girder or other form of compression ring shall not be used in connection with it, and there shall be no sudden changes in the direction of a meridional line at any point. In addition, the radius of curvature of the knuckle in a meridional plane shall be not

¹⁸If, for manufacturing reasons, it is uneconomical or impractical to use butt-welded longitudinal or meridional joints for a distance on either side of the juncture as computed using Equations 24 and 25 and the thickness of the plates involved does not exceed the applicable limits for lap joints as set forth in Table 5-2, the joints may be lap-welded provided that the plates joined in this way are not given credit for contributing to the net cross-sectional area provided for resisting compressive forces in the compression-ring region. In such a case, however, computation of (a) force Q from Equation 26, (b) the width of the horizontal projection (see 5.12.5) and (c) the centroid of the composite corner compression region (see 5.12.5) shall be made as though these plates did actually participate in resisting the compressive force.

less than 6%, and preferably not less than 12%, of the diameter of the sidewalls. Subject to the provisions of 5.12.3.2, the thickness of the knuckle at all points shall satisfy the requirements of 5.10. Use of a knuckle radius as small as 6% of the sidewall diameter will frequently require an excessively heavy thickness for the knuckle region. The thickness requirement for such a region will be found more reasonable if a larger knuckle radius is used.

5.12.3.2 The designer should recognize that applying the equations in 5.10.2 to levels immediately above and below a point where two surfaces of differing meridional curvature have a common meridional tangent (for example, at the juncture between the knuckle region and the spherically dished portion of a tori spherical roof) will result in the calculation of two latitudinal unit forces, differing in magnitude and perhaps in sign, at the same point. The exact latitudinal unit force at this point will be intermediate between the two calculated values, depending on the geometry of the tank wall in that area; the designer may adjust the immediately adjacent thicknesses accordingly.

5.12.4 Compression Rings

5.12.4.1 The variables used in Equations 24–27 are defined as follows:

- w_h = width, in in., of the roof or bottom plate considered to participate in resisting the circumferential force acting on the compression-ring region,
- w_c = corresponding width, in in., of the participating sidewall plate,
- t_h = thickness, in in., of the roof or bottom plate at and near the juncture of the roof or bottom and sidewalls, including corrosion allowance,
- t_c = corresponding thickness, in in., of the cylindrical sidewalls at and near the juncture of the roof bottom and sidewalls,
- R_2 = length, in in., of the normal to the roof or bottom at the juncture between the roof or bottom and the sidewalls, measured from the roof or bottom to the tank's vertical axis of revolution,
- R_c = horizontal radius, in in., of the cylindrical sidewall at its juncture with the roof or bottom of the tank,
- T_1 = meridional unit force (see 5.10) in the roof or bottom of the tank at its juncture with the sidewall, in lbf/in. of circumferential arc,
- T_2 = corresponding latitudinal unit force (see 5.10) in the roof or bottom, in lbf/in. of meridian arc,
- T_{2s} = circumferential unit force (see 5.10) in the cylindrical sidewall of the tank at its juncture with the roof

or bottom, in lbf/in. measured along an element of the cylinder,

α = angle between the direction of T_1 and a vertical line. (In a conical surface it is also one-half the total vertex angle of the cone.)

Q = total circumferential force, in lb, acting on a vertical cross section through the compression-ring region,

A_c = net area, in in.², of the vertical cross section of metal required in the compression-ring region, exclusive of all corrosion allowances,

S_{ts} = maximum allowable stress value for simple tension, in lbf/in.², as given in Table 5-1,

E = efficiency, expressed as a decimal, of meridional joints in the compression-ring region in the event that Q should have a positive value, indicating tension (see Table 5-2).

5.12.4.2 If a curved knuckle is not provided, the circumferential compressive forces mentioned in 5.12.2 must be resisted by other means in the compression-ring region of the tank walls. This region shall be understood to be the zone of the tank walls at the juncture between the roof or bottom and the sidewalls, including the width of plate on each side of the juncture that is considered to participate in resisting these forces (see Figure 5-5). In no event shall the thickness of the wall plate on either side of the juncture be less than the thickness needed to satisfy the requirements of 5.10. The widths of plate making up the compression-ring region shall be computed using the following equations:

$$w_h = 0.6\sqrt{R_2(t_h - c)} \quad (24)$$

$$w_c = 0.6\sqrt{R_c(t_c - c)} \quad (25)$$

5.12.4.3 The magnitude of the total circumferential force acting on any vertical cross section through the compression-ring region shall be computed as follows:

$$Q = T_2 w_h + T_2 w_c - T_1 R_c \sin \alpha \quad (26)$$

The net cross-sectional area provided in the compression-ring region shall be not less than that found to be required by one of the following equations:

$$A_c = Q/15,000 \text{ or } Q/S_{ts}E \quad (27)$$

The selection of Equation 27 depends on whether the value of Q as determined by Equation 26¹⁹ is negative or positive.

5.12.5 Details of Compression-Ring Regions

5.12.5.1 If the force Q is negative, indicating compression, then the horizontal projection of the effective compression-ring region shall have a width in a radial direction not less than 0.015 times the horizontal radius of the tank wall at the level of the juncture between the roof or bottom and the sidewalls; if the projected width does not meet this requirement, appropriate corrective measures shall be applied as specified in this section.

5.12.5.2 Whenever the magnitude of the circumferential force Q determined in accordance with 5.12.4 is such that the area required by Equation 27 is not provided in a compression-ring region with plates of the minimum thicknesses established by the requirements of 5.10 or when Q is compressive and the horizontal projection of the width, w_h , is less than specified in 5.12.5.1, the compression-ring region shall be reinforced by (a) thickening the roof or bottom and sidewall plates as required to provide a compression-ring region having the necessary cross-sectional area and width as determined on the basis of the thicker plates,²⁰ (b) adding an angle, a rectangular bar, or a horizontally disposed ring girder at the juncture of the roof or bottom and sidewalls plates, or (c) using a combination of these alternatives. This additional area shall be arranged so that the centroid of the cross-sectional area of the composite corner compression region lies ideally in the horizontal plane of the corner formed by the two members. In no case shall the centroid be off the plane by more than 1.5 times the average thickness of the two members intersecting at the corner.

5.12.5.3 Such an angle, bar, or ring girder, if used, may be located either inside or outside the tank (see Figure 5-6) and shall have a cross section with dimensions that satisfy the following conditions:

- The cross-sectional area makes up the deficiency between the area A_c required by Equation 27 and the cross-sectional area provided by the compression-ring region in the walls of the tank.
- The horizontal width of the angle, bar, or ring girder is not less than 0.015 times the horizontal radius, R_c , of the tank wall at the level of the juncture of the roof or bottom and the

¹⁹Because of the discontinuities and other conditions found in a compression-ring-region, biaxial-stress design criteria are not considered applicable for a compressive force determined as in Equation 26. Experience has shown that a compressive stress of the order of 15,000 lbf/in.², as indicated in Equation 27, is permissible in this case, provided the requirements of 5.12.5 are satisfied.

²⁰Note that unless the effect of the unit forces T_2 and T_2 , on the resulting increments in width of participating plate may be safely neglected, the use of thicker plates involves recomputing not only T_h and W_c , but also Q and A for the increased plate thickness; hence the design of the compression-ring-region in this case becomes a trial-and-error procedure.

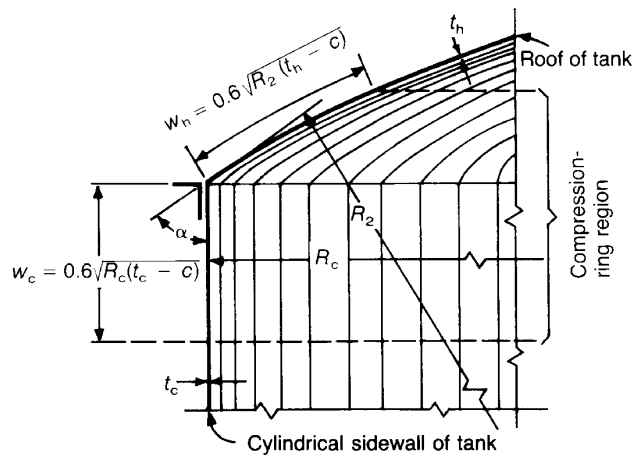

Figure 5-5—Compression-Ring Region

sidewalls except that when the cross-sectional area to be added in an angle or bar is not more than one-half the total area required by Equation 27, the foregoing width requirement for this member may be disregarded if the horizontal projection of the width, w_h , of the participating roof or bottom plates alone is equal to or greater than $0.015R_c$ or, with an angle or bar located on the outside of a tank, the sum of the projection of the width, w_h , and the horizontal width of the added angle or bar is equal to or greater than $0.015R_c$.

c. When bracing must be provided as specified in 5.12.5.8, the moment of inertia of the cross section around a horizontal axis shall be not less than that required by Equation 28.

5.12.5.4 When the vertical leg of an angle ring or a vertical flange of a ring girder is located on the sidewall of the tank, it may be built into the sidewall if its thickness is not less than that of the adjoining wall plates. If this construction is not used, the leg, edge, or flange of the compression ring next to the tank shall make good contact with the wall of the tank around the entire circumference and shall be attached thereto along both the top and bottom edges by continuous fillet welds except as provided in 5.12.5.5. These welds shall be sufficiently sized to transmit to the compression-ring angle, bar, or girder that portion of the total circumferential force, Q , which must be carried thereby, assuming in the case of welds separated by the width of a leg or flange of a structural member as shown in Figure 5-6, details a and h, that only the weld nearest the roof or bottom is effective. In no event, however, shall the size of any weld along either edge of a compression ring be less than the thickness of the thinner of the two parts joined or $1/4$ in. (whichever is smaller), nor shall the size of the corner welds between the shell and a girder bar, such as shown in Figure 5-6, details d and e, be less than the applicable weld sizes in Table 5-8. The part thicknesses and weld sizes in Table 5-8 relate to dimensions in the as-welded condition before the deduction of corrosion allowances; with this

exception, all other part thicknesses and weld sizes referred to in this paragraph relate to dimensions after the deduction of corrosion allowance.

5.12.5.5 If a continuous weld is not needed for strength or as a seal against corrosive elements, attachment welds along the lower edge of a compression ring on the outside of a tank may be intermittent if (a) the summation of their lengths is not less than one-half the circumference of the tank, (b) the unattached width of tank wall between the ends of welds does not exceed eight times the tank wall thickness exclusive of corrosion allowance, and (c) the welds are sized as needed for strength (if this is a factor), but in no case are they smaller than specified in Table 5-8.

5.12.5.6 The projecting part of a compression ring shall be placed as close as possible to the juncture between the roof or bottom plates and the sidewall plates.

5.12.5.7 If a compression ring on either the inside or outside of a tank is shaped in such a way that liquid may be trapped, it shall be provided with adequate drain holes uniformly distributed along its length. Similarly, if a compression ring on the inside of a tank is shaped in such a way that gas would be trapped on the underside when the tank is being filled with liquid, adequate vent holes shall be provided along its length. Where feasible, such drain or vent holes shall be not less than $3/4$ in. in diameter.

5.12.5.8 The projecting part of a compression ring without an outer vertical flange need not be braced if the width of the projecting part in a radial vertical plane does not exceed 16 times its thickness. With this exception, the horizontal or near-horizontal part of the compression ring shall be braced at intervals around the circumference of the tank with brackets or other suitable members securely attached to both the ring and the tank wall to prevent that part of the ring from buckling laterally (vertically) out of its own plane. When bracing is required, the moment of inertia of the cross section of the angle, bar, or ring girder about a horizontal axis shall be not less than that computed by the following equation:

$$I_1 = \frac{1.44 Q_p R_c^2}{29,000,000 k} = (0.00000005) \frac{Q_p R_c^2}{k} \quad (28)$$

where

I_1 = required moment of inertia, in in. to the fourth power, for the cross section of a steel²¹ compression ring with respect to a horizontal axis through the centroid of the section (not taking credit for any portion of the tank wall) except that in the case of an angle ring whose vertical leg is attached to or

²¹The value for I_1 as computed using Equation 28 is not applicable for materials other than steel.

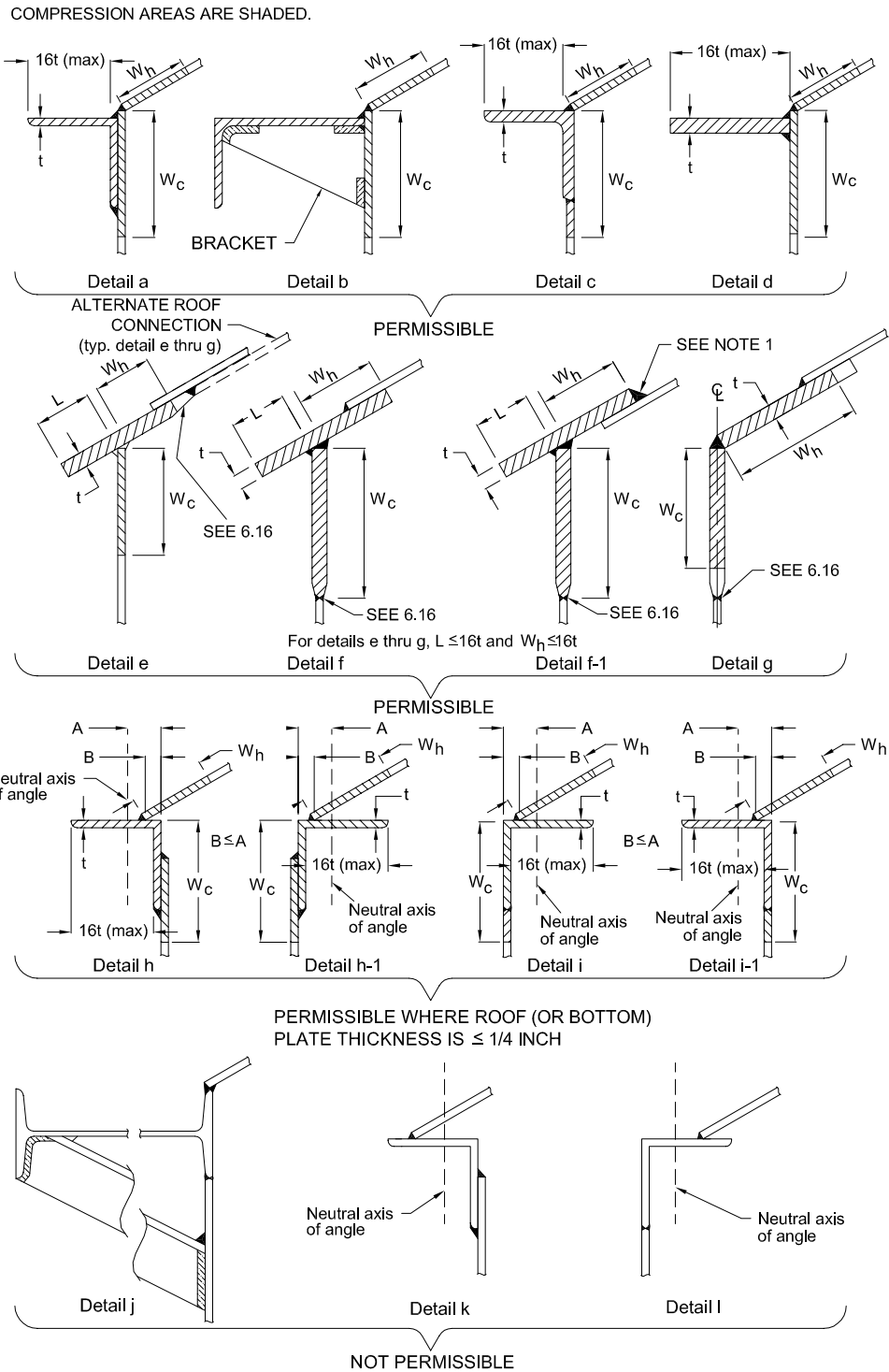

Notes:

1. When using the alternate roof position (the roof plate under the compression bar as shown in detail f-1), the purchaser should consider the use of caulking on top of the fillet weld to ensure the drainage of rainfall.
2. See Table 5-2 for limitations concerning locations where various types of welded joints may be used and 5.12.2 for limits on material contributing to compression cross-sectional area.

Figure 5-6—Permissible and Nonpermissible Details of Construction for a Compression-Ring Juncture

Table 5-8—Minimum Size of Fillet Weld

Thickness of the Thicker of the Two Parts Joined (in.)	Minimum Size of Fillet Weld (in.)
$\leq 1/4$	$3/16$
$> 1/4 - 3/4$	$1/4$
$> 3/4 - 1 1/4$	$5/16$
$> 1 1/4$	$3/8$

forms a part of the tank wall, the moment of inertia of the horizontal leg only shall be considered and shall be figured with respect to a horizontal axis through the centroid of the leg,

Q_p = that portion of the total circumferential force Q (see Equation 26) that is carried by the compression-ring angle, bar, or girder as computed from the ratio of the cross-sectional area of the compression ring to the total area of the compression zone,

R_c = horizontal radius, in in., of the cylindrical sidewall of the tank at its juncture with the roof or bottom,

k = constant whose value depends on the magnitude of the angle θ subtended at the central axis of the tank by the space between adjacent brackets or other supports, the value of which shall be determined from Table 5-9 in which n is the number of brackets or other supports evenly spaced around the circumference of the tank. In no case shall θ be larger than 90 degrees.

5.13 DESIGN OF INTERNAL AND EXTERNAL STRUCTURAL MEMBERS

5.13.1 General

The provisions of 5.13.2 through 5.13.5 are limited to a discussion of the basic requirements and principles involved. For reasons that will appear obvious, specific design formulas cannot be included.

5.13.2 Basic Requirements

5.13.2.1 Wherever the shape selected for a tank is such that the tank, or some portion thereof, would tend to assume an appreciably different shape under certain conditions of loading or whenever the shape is such that it is not feasible or economical to design the walls themselves to carry the entire loads imposed by all possible combinations of gas and liquid loadings that may be encountered in service, suitable internal ties, columns, trusses, or other structural members shall be provided in the tank to preserve its shape and to carry the forces that are not carried directly by the walls of the tank.

Other structural members may be needed on the outside of a tank to support or partly support the weight of the tank and its contents, and these shall be provided as required. All such internal and external members shall be designed in accordance with good structural engineering practices, using stresses as specified in 5.6. They shall be arranged and distributed in or on the tank and connected to the walls of the tank (in cases where such connections are needed) in such a way that reactions will not cause excessive localized or secondary stresses in the walls of the tank. When these members are rigidly attached to the wall of a tank by welding, the stresses in the member at the point of attachment shall be limited to the stress value permitted in the wall of the tank (see Appendix D).

5.13.2.2 In no event shall the nominal thickness, including the corrosion allowance, if any, of any part of any internal framing be less than 0.17 in.

5.13.2.3 If any structural members (such as girders at node circles), tank accessories, or other internals are placed to form gas pockets inside a tank, adequate and suitably located vent holes shall be provided so that these spaces will vent freely when the liquid level is raised beyond them. Similarly, if any such members, accessories, or other internals are shaped to hold liquid above them when the tank is being emptied, they shall be provided with adequate and suitably located drain holes. These vent and drain holes shall be not smaller than $3/4$ in. in diameter and shall be distributed along the member.

5.13.3 Simple Systems

In some cases the forces acting on structural members are statically determinate; in other cases, they are statically indeterminate. The external columns that are often used for supporting a spherical tank are an example of the statically determinate class of members. If the columns are vertical, the force acting on each column is simply the combined weight of the tank and its contents divided by the number of columns. If the columns are inclined, this quotient must be divided by the cosine of the angle each column makes with the vertical to obtain the force acting in each column.

To cite another case, where internal framing is needed inside a tank only to support the weight of the roof and such loads (including external pressure load, if any) as may be superimposed upon it, the procedure for designing such framing is more or less straightforward, involving only a few assumptions. In other cases, however, whenever the internal framing serves to supplement the load-carrying capacity of the walls of the tank, the design procedure is more complex.

5.13.4 Complex Systems

5.13.4.1 The design rules in this standard do not cover specific requirements for designing the internal framing in all the various shapes of tanks that might be constructed, but an out-

line of the procedure used in the design of internal framing for one special shape of tank, as shown in Figure 5-4, panel c, should serve to illustrate the general method of attack. In such a system of internal framing, the magnitude of the forces in the tension members, which tie the ring girders under the roof node circles to the respective girders above the bottom node circles, are determined by static, assuming for the purpose of a preliminary analysis that these tension members are replaced by a cylindrical shell if the members are vertical or by a conical frustum if the members are inclined.

5.13.4.2 Under these assumed conditions, the vertical components of the T_1 (meridional) unit forces in the roof plates at their juncture with the cylinder or frustum are transmitted directly to the cylinder or frustum so that an upper ring girder is unnecessary in this hypothetical case if (a) the horizontal components of the T_1 unit forces in the roof or wall plates on opposite sides of the juncture balance each other in the case of the cylindrical tie or (b) the difference between them is balanced by the horizontal components of the unit forces in the top of the frustum in the case of the conical tie.

5.13.4.3 Similarly, at the lower end of the cylinder or frustum, the summation of the vertical components of the forces must be in balance with the vertical components of the forces in the cylinder or frustum, and the summation of the horizontal components of the forces acting at the juncture must be zero. Furthermore, the total vertical force acting along the edges of the top of the cylinder or frustum must equal the total vertical force acting along the edges of the bottom of the cylinder or frustum. In other words, the general layout of the tank must be such that the upward gas pressure over a predetermined portion of the roof is balanced by the downward gas pressure over a predetermined portion of the bottom without undue elastic stressing or straining.

5.13.4.4 If the horizontal forces at the node circles are not otherwise in equilibrium, ring girders must be provided at these circles. The girders must be designed to carry the unbalanced components—either in tension or compression, as the case may be.

5.13.4.5 Having satisfied the conditions of static equilibrium using a hypothetical cylinder or frustum for a tie, the designer must consider and provide for the real conditions where the cylinder or frustum is approximated by a number of uniformly spaced structural members, each of which, in addition to its primary function as a tie, serves also as a column to support its assigned portion of the roof and external loads. The torsional and vertical moments in the ring girders at the node circles must be provided for, keeping in mind that relatively small variations from the nominal T_1 (meridional) roof forces will greatly reduce, if not completely offset, the torsional moments in the girders.

Table 5-9—Factors for Determining Values of k for Compression-Ring Bracing (See 5.12.5.8)

n	θ (degrees)	k
30	12	186.6
24	15	119.1
20	18	82.4
18	20	66.6
15	24	46.0
12	30	29.1
10	36	20.0
9	40	16.0
8	45	12.5
6	60	6.7
5	72	4.4
4	90	2.6

5.13.5 Internal Meridional Stiffeners

5.13.5.1 When curved meridional trusses or ribs are fastened to the sidewalls of a tank to prevent the T_1 (meridional) compressive forces from buckling the sidewalls, the distribution of meridional forces between the sidewalls and trusses or ribs is to a degree indeterminate if the foundation support for the overhanging portions of the sidewalls is so uniformly distributed around the tank that there is no greater foundation-bearing intensity against the tank wall beneath the trusses or ribs. In this case, the total meridional forces that the sidewalls and trusses or ribs must carry, acting together, at any given level in the tank may be computed from Equation 1 in 5.10.2.1, assuming for the purposes of these computations only that the cross-sectional area of the trusses or ribs is distributed uniformly along the circumference of the sidewalls as an added sidewall thickness. In other words, the value of F in Equation 1 may be taken as not including the forces in these trusses or ribs, and the hypothetical value of the meridional unit force computed using Equation 1 may be regarded as the summation of all meridional forces acting on the composite section of sidewalls and trusses or ribs at the level under consideration divided by the circumference of the tank at that level.

5.13.5.2 The net cross-sectional area of metal (exclusive of corrosion allowance) required per inch of tank circumference to resist these forces may then be determined by dividing the hypothetical value of the meridional unit forces acting on the composite section by allowable compressive stress. This area must then be apportioned between the sidewalls and the trusses or ribs, by trial-and-error computations, in such a way

that (a) sufficient material is placed in the trusses or ribs to enable them to serve their intended function of preventing buckling of the sidewalls in a vertical direction (the trusses or ribs must also be proportioned and distributed around the circumference of the tank so that they will serve this function) and (b) sufficient thickness is provided in the sidewalls to enable them to withstand not only their share of the meridional unit forces but also the entire latitudinal unit force T_2 as computed by the following equation:

$$T_2 = R_2(P - T_1/R_1)$$

In this equation, T_1 is the meridional unit force assumed to be actually carried by the sidewalls and is obtained by multiplying the hypothetical value of the meridional unit forces acting on the composite section by the ratio of the sidewall cross-sectional area to the composite cross-sectional area at the level in question. Other variables used in the foregoing equation are defined in 5.10.1, and the thickness provided to resist this force T_2 must satisfy all of the requirements of 5.10.3 that involve this force.

5.13.5.3 No such uniform distribution of forces on the composite section of sidewalls and trusses or ribs actually occurs. However, the assumption of uniform distribution of 5.13.5.1 and 5.13.5.2 will give safe designs if the principles outlined are observed and the eccentricity of loading on the trusses or ribs is taken into account. (New designs shall be proved by strain-gauge surveys.)

5.13.5.4 In the case of a tank whose foundations and supports are designed and arranged so that the weight of the overhanging portions of the tank and its contents is transferred entirely to the trusses or ribs and from there to the foundations, the total load on each truss or rib is determinate. The stress system in the tank wall is analogous to that in a large horizontal pipeline supported entirely on ring girders. In the latter case, design stresses comparable to those permitted in 5.13.5.2 may be used insofar as sidewall thicknesses are governed by forces acting in a meridional direction.

5.14 SHAPES, LOCATIONS, AND MAXIMUM SIZES OF WALL OPENINGS

5.14.1 The term opening as used in this section, 5.16, 5.17, and 5.18 refers to the hole cut in a tank wall to accommodate a nozzle, manway, or other connection (rather than just the bore of the connection) except when the wall of a connection extends through the tank wall and is attached to it with sufficient weld within the tank wall thickness to develop the strength in tension of that section of the wall of the connection which lies within the tank wall thickness (that is, the strength of an area equal to twice the product of the nozzle wall thickness and the tank wall thickness) in addition to whatever welding is required at this location for reinforce-

ment attachment. In the latter case, when the wall of a connection is attached to the tank wall in this way, opening refers to the figure formed by the imaginary line of intersection between the inside surface of the connection and the surface of the tank wall extended.

5.14.2 In all cases, requirements concerning openings shall be understood to refer to dimensions that apply to the corroded condition. Unless otherwise specified, dimensions of openings generally refer to measurements taken along the chord of the tank wall curvature if the wall is curved in the direction involved; however, when there is more than approximately a 2% difference between the length of chord and the length of the arc that is subtends in the tank wall, the measurement shall be taken along the arc of the tank wall curvature.

5.14.3 The rules in this section shall also apply to openings in cylindrical shells that are adjacent to a relatively flat bottom; as an alternative, the insert plate or reinforcing plate may extend to and intersect the bottom-to-shell joint at approximately 90°. Stress-relieving requirements do not apply to the weld to the bottom or annular plate.

5.14.4 All manholes, nozzle connections, or other connections in the sidewalls, roofs, or bottoms of tanks constructed under these rules shall be circular, elliptical,²² or obround²³ in shape. Where elliptical or obround connections are employed, the long dimensions shall not exceed twice the short dimension, as measured along the outer surface of the tank; if the connection is in an area of unequal meridional and latitudinal stresses in the tank wall, the long dimension shall preferably coincide with the direction of the greater stress.

5.14.5 Each opening in the walls of a tank shall be located so that the distance between the outer edge of its reinforcement²⁴ and any line of significant discontinuity in the curvature of the tank walls (such as the juncture between two nodes in a noded surface, the juncture between a dished or conical roof or bottom and cylindrical sidewalls, or the juncture between a roof or bottom and cylindrical sidewalls, or the juncture between a roof or bottom knuckle and other portions of the tank) is not less than 6 in. or (if this be larger) eight times the nominal thickness (including corrosion allowance; if any) of the wall plate containing the opening, except as permitted by 5.14.3. No part of the attachment for any openings shall be located closer than the larger of these distances to any

²²An opening made for a pipe or nozzle of circular cross section whose axis is not perpendicular to the tank wall shall be treated as an elliptical opening for design purposes.

²³An obround figure is one that is formed by two parallel sides and semi-circular ends.

²⁴The term edge of reinforcement means the edge, or toe, of the outermost weld that attaches the reinforcing pad to the wall of the tank. In the case of an opening that is not provided with a reinforcing pad, it means the neck of the nozzle or other connection extending from the opening to the tank wall.

part of the attachment for any lugs, columns, skirts, or other members attached to the tank for supporting the tank itself or for supporting important loads that are carried by the tank. When any two adjacent openings are reinforced independently of each other, they shall be spaced so that the distance between the edges of their respective reinforcements will not at any point be less than the larger of the foregoing specified distances (see 5.17).

5.14.6 Each opening shall be located so that any attachments and reinforcements will be, or may readily be made, fully accessible for inspection and repair on both the outside and inside of the tank except in the case of connections that for compelling reasons must be located on the underside of a tank bottom resting directly on the tank foundation.

5.14.7 Properly reinforced openings may be of any size²⁵ that can be located on the tank to comply with the requirements of 5.14.5 and 5.14.6 except that in no event shall the inside diameter (after allowing for corrosion) of any opening²⁶ other than those considered in 5.18 exceed 1.5 times the least radius of curvature in that portion of the tank wall in which the opening is located.

5.14.8 Large openings shall be given special consideration (see 5.16.7 and 5.18). In the case of large openings which have attachments that require shop stress relief (see 5.25.1), shipping clearances, affecting the maximum size of assembly that can be shipped, may control the size of the opening that can be used.

5.15 INSPECTION OPENINGS

Each tank shall be provided with at least two manhole openings to afford access to its interior for inspection and repair. Manholes shall in no event be smaller than 20 in. along any inside dimension. All manholes shall be made readily accessible by platforms and ladders, stairways, or other suitable facilities.

5.16 REINFORCEMENT OF SINGLE OPENINGS

5.16.1 General

The requirements of this paragraph are illustrated in Figures 5-7 and 5-8. See 5.21.1.2, 5.21.1.3, 5.21.2.7, and 5.21.2.8 for provisions concerning reinforcement of openings in cover plates for nozzles.

²⁵Although no minimum size is prescribed, it is recommended that no nozzle smaller than $\frac{3}{4}$ in. pipe be used on a tank constructed according to these rules.

²⁶In the case of elliptical or obround openings, the dimension of the opening in any given direction shall meet this requirement with respect to the radius of curvature of the tank wall in that direction.

5.16.2 Basic Requirements

All openings in the walls of tanks constructed according to these rules and all openings for branch connections²⁷ from nozzle necks welded to the tank wall shall be fully reinforced with the exception of the exclusions covered in 5.16.2.1 and 5.16.2.2.

5.16.2.1 Single openings in tanks do not require reinforcement other than that which is inherent in their construction for the following conditions:

- Three in., or less, pipe size welded connections in tank walls $\frac{3}{8}$ in. or less.
- Two in., or less, pipe size welded connections in tank walls over $\frac{3}{8}$ in.
- Threaded connections in which the hole in the tank wall is not greater than 2 in. pipe size.

5.16.2.2 The reinforcement required for openings in tank walls for external pressure conditions need be only 50% of that required in 5.16.5 where t has been determined for external pressure conditions.

5.16.2.3 The requirements for full reinforcement shall not be construed as requiring that a special reinforcing pad be provided where the necessary reinforcing metal is available in the nozzle neck or elsewhere around the opening as permitted by these rules. The amount of reinforcement required, the limiting dimensions within which metal may be considered to be effective as reinforcement, and the strength of the welding required for attaching the reinforcement are defined in 5.16.3. Reinforcement shall be provided in the specified amount and shall be distributed and attached to the wall of the tank in such a way that the requirements are satisfied for all paths of potential failures through the opening extended in either a meridional or latitudinal direction.

5.16.2.4 The maximum amount of reinforcement will be needed in a plane that is perpendicular to the direction of principal wall stress passed through the opening at the point where the centerline of the connection intersects the wall of the tank; for obround openings, that same amount must be provided along the entire length of the parallel sides of the opening between the planes passing through the respective centers of the semicircular ends. However, these planes may not be the controlling sections with respect to possible failure through the opening, inasmuch as failure might occur along another path (in the case of a cylindrical wall, parallel to, but somewhat removed from, the aforesaid planes) by a combina-

²⁷The design rules in this section make no mention of openings for branch connections from nozzle necks, but the provisions shall be understood to apply to openings of this type. For this purpose, the term *tank wall* shall refer to the neck of the main nozzle to which the branch connection is attached, and the term *nozzle wall* shall refer to the wall of the branch connection.

02 |

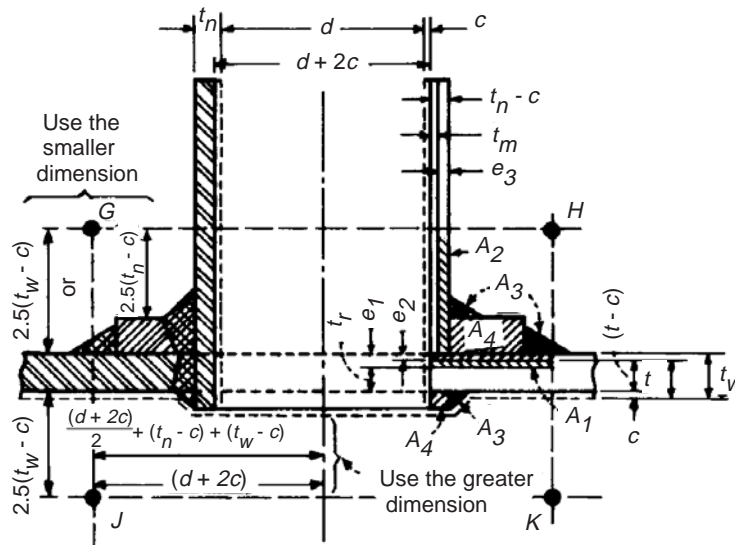

t_r = Required thickness of a seamless wall (or solid plate); if the opening passes through a welded joint whose direction is parallel to the cross section under consideration, t_r shall be given a value that allows for the difference, if any, between the specified efficiency of the joint and an efficiency of 100%.

t_m = Required thickness of the nozzle neck, allowing for the efficiency of longitudinal joints, if any, in the nozzle neck.

e_1 = Excess thickness if the opening is in solid plate.

e_2 = Excess thickness if the opening passes through a welded joint that has an efficiency of less than 100% and whose direction is parallel to the cross section under consideration.

e_3 = Thickness of the nozzle neck available for reinforcement of the opening.

A_1 = Area in excess thickness of the tank wall that is available for reinforcement.

A_2 = Area in excess thickness of the nozzle neck that is available for reinforcement.

A_3 = Cross-sectional area of welds available for reinforcement.

A_4 = Cross-sectional area of material added as reinforcement.

Note: See 5.16.5.1 and Figure 5-8 for definitions of other variables.

Figure 5-7—Reinforcement of Single Openings

tion of a tensile failure of the tank wall and shearing or tensile failure of the attachment welds.

5.16.3 Size and Shape of Area of Reinforcement

5.16.3.1 The area of reinforcement for a given cross section of an opening shall be understood to be that area in a plane normal to the surface of the tank and passing through the section under consideration within which available metal may be deemed effective for reinforcing the opening. For surfaces that have straight elements, such as cylinders and cones, the areas of reinforcement will be rectangular in shape as indicated by lines GH, HK, GJ, and JK in Figure 5-7; however, on surfaces that are curved in two directions, the lines GH and JK shall follow the contour of the tank surface.

5.16.3.2 The maximum length of the area of reinforcement shall be the greater of the following limiting distances on each side of the axis of the opening, measured along the outside surface of the tank:

- A distance equal to the diameter of the opening after corrosion; in the case of non circular openings, a distance equal to the corresponding clear dimension is substituted for the diameter of the opening.
- A distance equal to the radius of the opening after corrosion plus the thickness of the nozzle wall plus the thickness of the tank wall, all taken in the corroded condition; in the case of non circular openings, a distance equal to the corresponding half chord is substituted for the radius of the opening.

5.16.3.3 The maximum width of the area of reinforcement, measured radially as applicable from either the inner or outer surface of the tank wall, or both, shall be not more than the smaller of the two following distances:

- A distance equal to 2.5 times the nominal thickness of the tank wall less the corrosion allowance.
- A distance equal to 2.5 times the nominal thickness of the nozzle wall less its corrosion allowance plus the thickness of any additional reinforcement inside or outside the tank wall

less its corrosion allowance if the reinforcement considered is inside the tank.

5.16.3.4 If the areas of reinforcement computed for two or more adjacent openings overlap, the openings shall be reinforced as provided in 5.17.

5.16.4 Metal Considered To Have Reinforcing Value

5.16.4.1 Subject to the provisions of 5.16.7, the metal within the limits of the area of reinforcement as described in 5.16.4.2 and 5.16.4.3 may be considered to act as reinforcement.

5.16.4.2 Metal thickness in the tank wall in excess of that required by 5.10 for 100% joint efficiency may be considered to act as reinforcement when the entire opening is in solid plate or in excess of that required for the applicable design joint efficiency when any part of the opening passes through a joint that lies in approximately the same meridional or latitudinal direction²⁸ as the cross section of the opening for which the reinforcement requirements are being computed. In no case does this include any metal provided for corrosion allowance. If desired, the wall thickness may be arbitrarily increased to make additional amounts of excess thickness available for reinforcement in the tank wall instead of adding reinforcement locally in the form of reinforcing pads.

FIGURE 5-8 NOTES:

t_w = nominal thickness of the tank wall, in in., including corrosion allowance,

t_n = nominal minimum thickness of the nozzle neck, in in.in., including corrosion allowance,

t_p = nominal thickness of the reinforcing pad, in in., including corrosion allowance if the pad is exposed to corrosion,

c = corrosion allowance, in in.,

t_{\min} = the smaller of $3/4$ in. or the thickness less the corrosion allowance of either of the parts joined by a fillet weld or groove weld,

t_1 or t_2 = a value not less than the smaller of $1/4$ in. or $0.7t_{\min}$; the sum $t_1 + t_2$ shall not be less than $1.25t_{\min}$.

²⁸If part of an opening passes through a joint whose direction is approximately perpendicular to the cross section under consideration, the presence of the joint may be ignored in the computations for this cross section but must be taken into account in computations for reinforcement requirements along cross sections parallel to this joint (see 5.16.5).

t_3 = the smaller of $1/4$ in. or $0.7(t_n - c)$. (Inside corner welds may be further limited by a lesser length of projection of the nozzle wall beyond the inside face of the tank wall.)

t_4 = a value not less than $0.5t_{\min}$,

t_5 = a value not less than $0.7t_{\min}$,

t_h = nominal head thickness, in in.

Notes:

1. The weld dimensions indicated in this figure are predicated on the assumption that no corrosion is anticipated on the outside of the tank. If outside corrosion is expected, the outside weld dimensions shall be increased accordingly.

2. Exposed edges shown as rounded may be finished by light grinding to at least a $1/8$ in. radius or chamfered at 45 degrees to at least a $5/32$ in. width.

^a For 3-in. pipe size and smaller, see exemptions in 5.16.9.2.

5.16.4.3 All other metal attached to the tank wall in conformance with 5.16.8 may be considered to act as reinforcement, including those portions of fusion welds and the nozzle wall that remain available for reinforcement of the opening after deducting applicable corrosion allowances and allowing for the thickness of nozzle wall needed to satisfy minimum thickness and strength requirements for the nozzle wall itself (see 5.19).

5.16.5 Reinforcement Required

5.16.5.1 The total cross-sectional area of the reinforcement provided at any section through an opening and within the limits of the area of reinforcement as defined in 5.16.3 shall be not less than the value computed by the following equation:

$$A_r = (d + 2c)(t - c)(E')$$

where

A_r = area, in square in., to be provided in the reinforcement of the section under consideration,

d = inside clear dimension, in in., across the opening at the section under consideration before deducting the applicable corrosion allowance (see 5.14.1),

c = corrosion allowance, in in., for the part under consideration,

t = thickness, in in., required by 5.10 for the particular area of the tank wall in which the opening is located for resisting the unit forces that act in a direction perpendicular to the cross section under consideration,

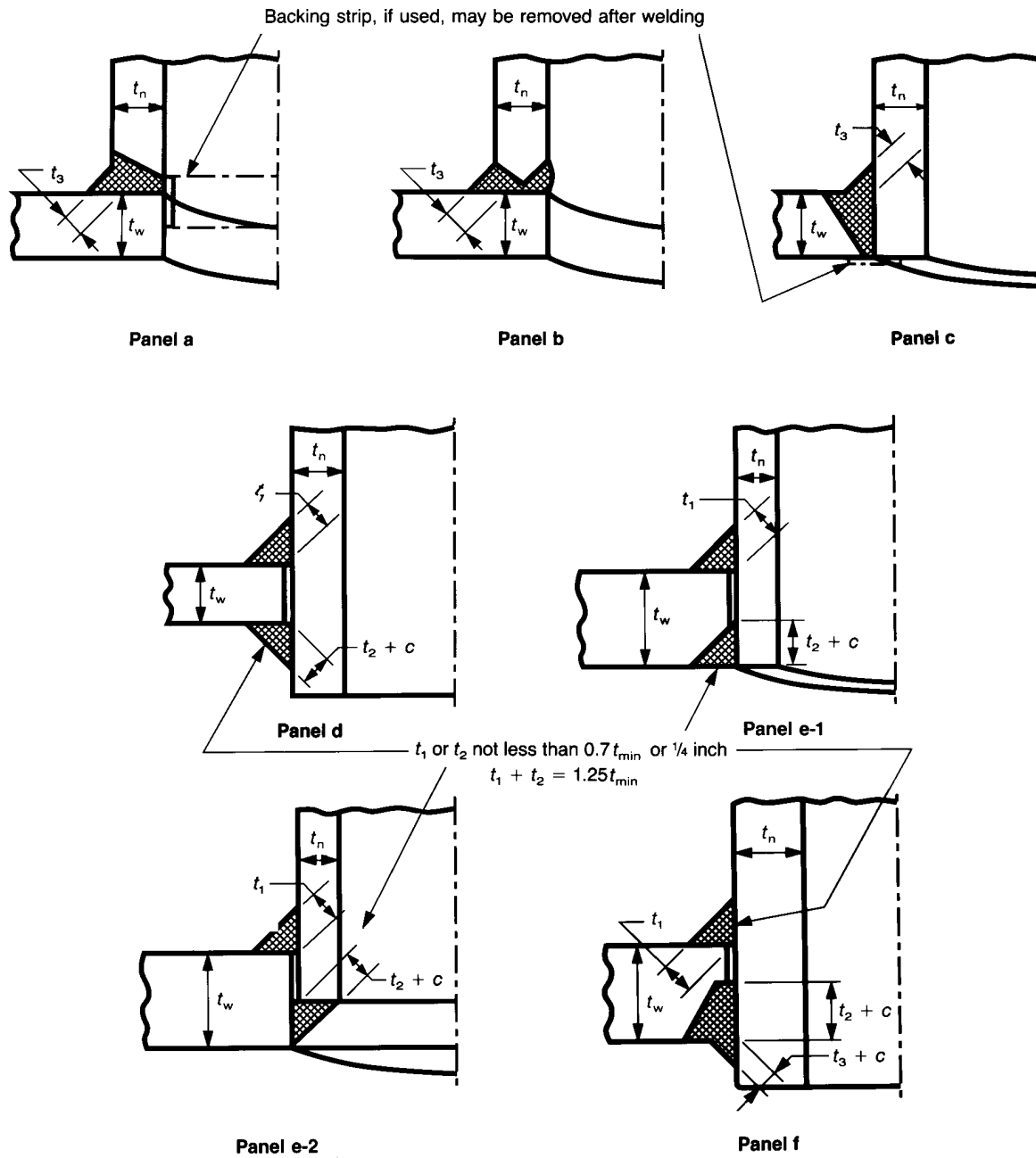

Figure 5-8—Part 1—Acceptable Types of Welded Nozzles and Other Connections

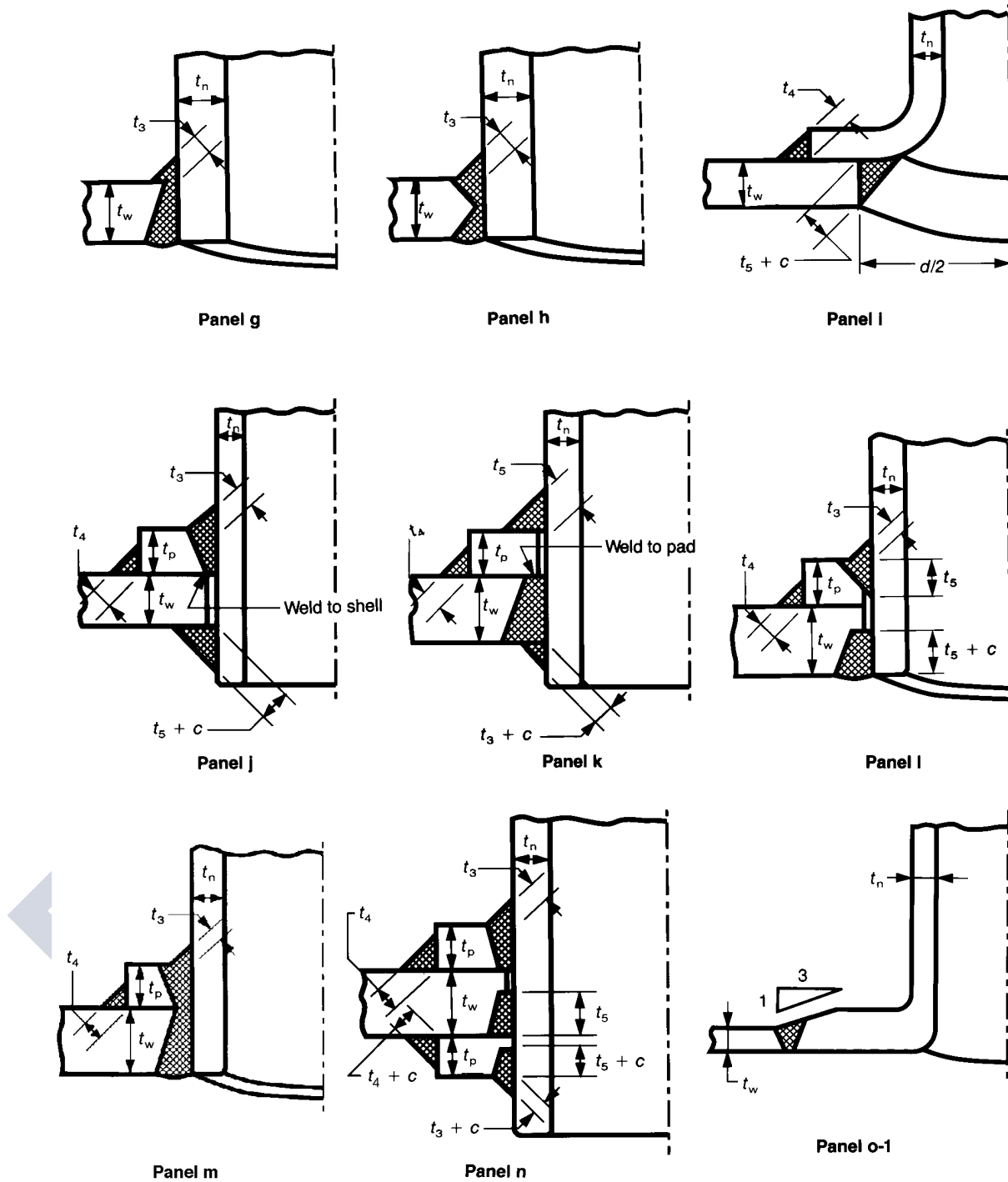

Figure 5-8-Part 2—Acceptable Types of Welded Nozzles and Other Connections

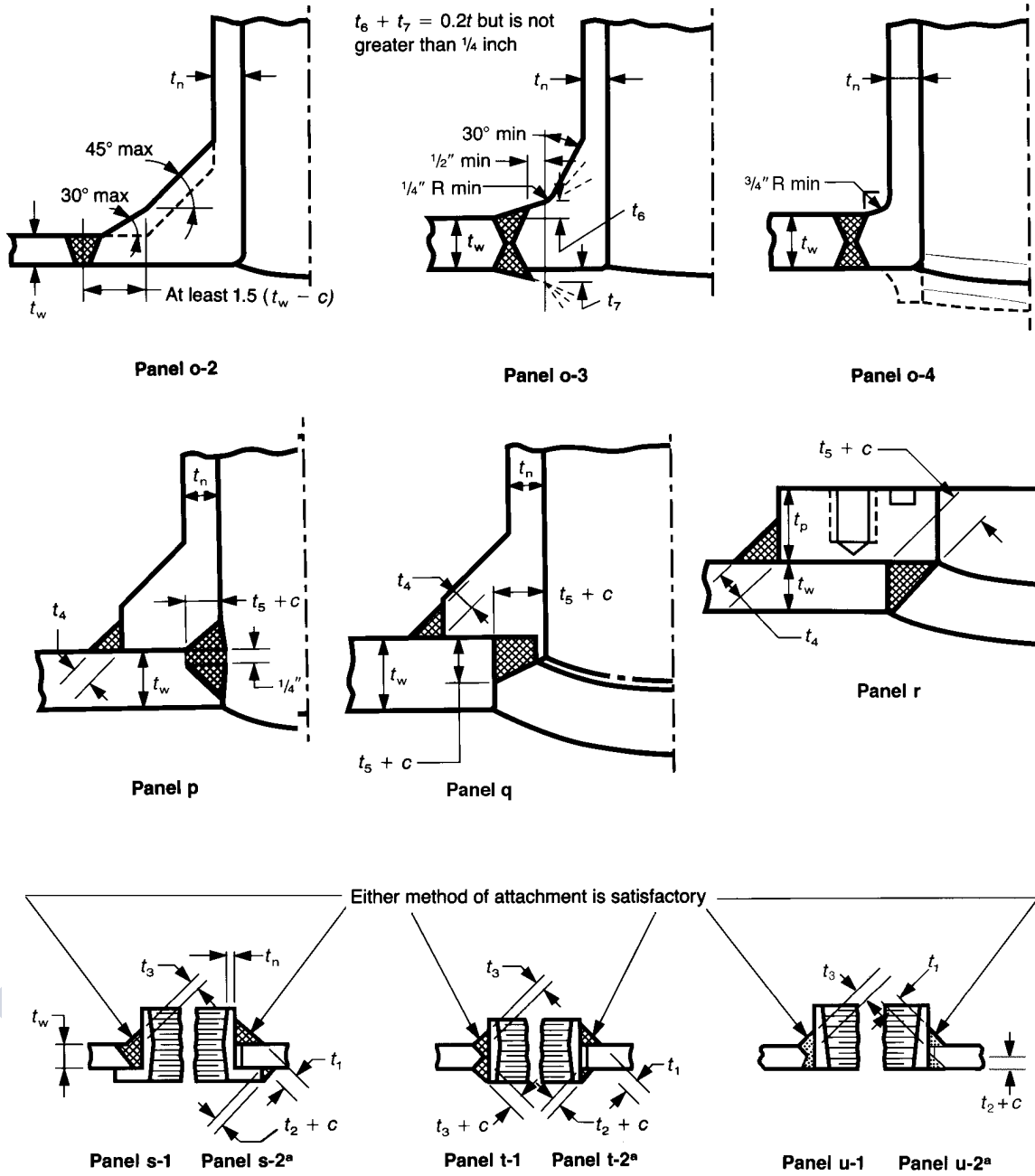

Figure 5-8—Part 3—Acceptable Types of Welded Nozzles and Other Connections

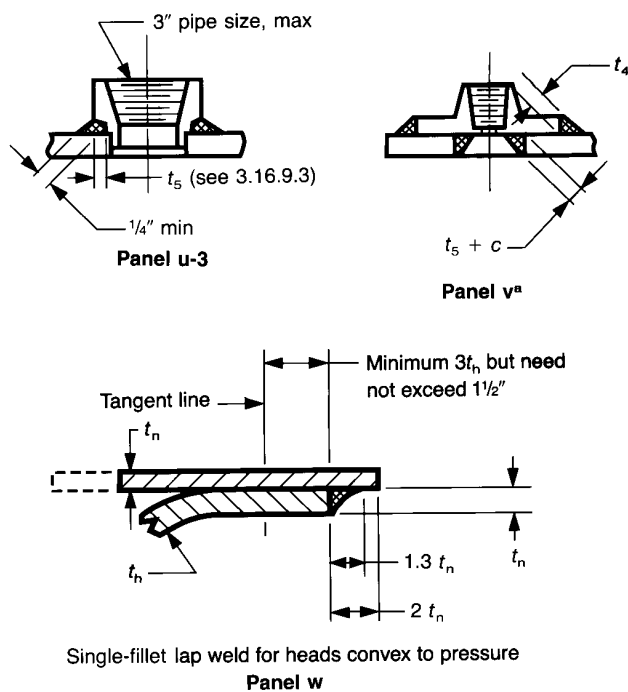

Figure 5-8—Part 4—Acceptable Types of Welded Nozzles and Other Connections

E' = factor whose value shall be equal to the efficiency, E , of the main joints along the edges of the tank wall plate containing the opening that are approximately parallel to the cross section under consideration where the opening is in solid plate or passes only through a joint that is substantially perpendicular to this cross section; and whose value shall be 1.00 where any part of the opening passes through a joint that is approximately parallel to the cross section under consideration (for values of E , see Table 5-2). The value of E' , when not taken as unity, shall be expressed as a decimal.

5.16.5.2 Consideration must be given to the reinforcement requirements for cross sections in both meridional and latitudinal directions, particularly on noncircular openings that have appreciable differences between their maximum dimensions in these two directions (see 5.16.2).

5.16.5.3 The equation in 5.16.5.1 assumes that all of the materials considered as reinforcement will have ultimate tensile strengths not less than the ultimate minimum tensile strength specified for the material in the tank wall. If some portion (such as the nozzle neck, if it is constructed of pipe) or all of the reinforcement material does not conform to this assumption, additional reinforcement shall be provided to

fully compensate for the lower ultimate tensile strength; in no case shall any credit be taken for the additional strength of any material of a tensile strength higher than that of the tank wall to be reinforced.

5.16.6 Distribution of Reinforcement

Reinforcement shall be distributed so that the strength of the reinforcement in each and every plane that constitutes a path of potential failure, as mentioned in 5.16.2, will be at least equal to the total load perpendicular to the same plane that would have been carried by the metal removed from the net wall thickness needed for that region of the tank if the metal had remained in the tank wall. The strength of the reinforcement is computed by multiplying the cross-sectional area of the reinforcing material provided within the area of reinforcement in that plane by the maximum allowable unit stress value for the reinforcement material (this value shall not exceed the allowable unit stress for the tank wall). In addition, the reinforcement shall preferably be shaped in section and welded to the tank wall in such a way that stress intensifications in the tank wall at the edges of the reinforcement will be kept as low as feasible.

5.16.7 Distribution of Reinforcement for Large Openings

5.16.7.1 The rules previously given for the reinforcement of openings are primarily intended for openings not larger than the following sizes:

- For surfaces that have a radius of curvature of 30 in. or less, the inside diameter (width or length) of the openings shall not exceed the radius of curvature of the surface in which the opening is located, nor shall it exceed 20 in. in any case.
- For surfaces whose least radius of curvature is over 30 in., the inside diameter (width or length) of the openings shall not exceed $\frac{2}{3}$ the least radius of curvature of the surface in which the opening is located, nor shall it exceed 40 in. in any case.

5.16.7.2 Openings larger than those just described, but still within the limits specified in 5.14.7, shall be given special consideration; except as otherwise provided in 5.18, the reinforcement shall meet all of the requirements previously given. In addition, special attention shall be given to placing the major portion of the reinforcement as close as practicable to the edge of the opening while still providing a reasonably gradual transition in contour from the thickness of the tank wall to the maximum thickness of the reinforcement. Wherever practicable, about $\frac{2}{3}$ of the required reinforcement shall be placed within a distance extending $\frac{1}{4}$ of the dimension d (as defined in 5.16.5) on each side of the opening.

5.16.7.3 Fillet welds may be ground to concave contour, and the inside corners of the tank wall or nozzle neck along the edges of the opening shall be rounded to a generous radius to reduce stress concentrations. Reinforcement may sometimes be more advantageously obtained by inserting a thicker plate or plates in that portion of the wall of the tank where the nozzle is located. However, when this is done, consideration shall be given to whether it would introduce an objectionable degree of restraint that might affect adjoining plates. The degree to which these and other measures should be used will depend on the particular application and the severity of the intended service. In extreme cases, appropriate proof testing may be advisable.

5.16.8 Strength Required In Welds

5.16.8.1 The reinforcement shall be attached using a method that develops the full strength required of the reinforcement at the centerline of the opening and provides adequate protection against failure that might occur in a plane (referred to herein as the critical plane) that is somewhat removed from the center of the opening as a result of tensile failure of the tank wall in combination with shearing or tensile failure of the reinforcement attachment (see 5.16.2.4). To this end, the welds and other parts of the assembly that serve as reinforcement attachment shall be properly located to transmit the stresses to the reinforcement, taking credit for only those portions of the attachment that lie beyond the critical plane—i.e., on the side of the plane opposite the center of the opening. Similarly, the strength of the attachment between any two parts of attached reinforcement beyond the critical plane shall be at least equal to the strength required in tension of the attached part or parts (see F.5 for examples illustrating the computation of reinforcement).

Note: Although the location of the critical plane may be determined analytically in most cases, it is not essential that it be determined analytically for the purposes of this section; the intent of the requirements in this section will be satisfied if (a) the critical plane is assumed to be located as specified in item 1 or 2 of this note and (b) sufficient welding and other attachments are provided beyond the plane (that is, on the side of the plane opposite the center of the opening) to develop the strength of the attached reinforcement required at the centerline of the opening. Attachment welds shall be made continuous around the entire periphery of the opening and reinforcement without any material reduction in size along the portions not credited as effective attachment in the computation. The critical plane locations to be assumed according to item a of this note shall be established from a consideration of the relative magnitude of the coincident biaxial stresses in the tank wall and the shape of the opening as follows:

1. For an opening in a spherical surface or in a surface of some other shape where neither of the principal biaxial stresses is less than 75% of the other, the critical plane shall be one that is perpendicular to the direction of the tank wall stress for which the reinforcement is being investigated; for a round or elliptical opening, the critical plane shall pass

through the center of the opening; for an obround opening, it shall pass through the center of one of the semicircular ends if a transverse section of the opening is being analyzed or coincides with the lengthwise centerline of the opening if a section in this direction is being analyzed.

2. For an opening in a cylindrical or conical surface or in a surface of some other shape where one of the principal biaxial stresses is less than 75% of the other, the critical plane shall be one that is parallel to the plane described in item 1 for the shape of opening involved but is located halfway between that plane and the edge of the opening (see Appendix F).

5.16.8.2 The strength of welds that attach the reinforcement shall be the strength in shear or tension depending on the possible mode of failure of the weld. When either shear or tension stress may be considered, the computations resulting in the lesser strength shall govern. Plug welds, wherever applicable, may be included in the strength of the attachment welding in conformance with 5.24. The thickness of the nozzle wall after corrosion may be included in the shear strength of the reinforcement attachment when the nozzle extends through the tank wall and is attached to it with a weld within the tank wall thickness that is sufficient to develop its strength in shear, which may not require full penetration through the tank wall. Some of the attachment welding may be placed outside the limits of the area of reinforcement as defined in 5.16.3; although it is not credited as reinforcement, this welding may nevertheless be counted as attachment welding if it qualifies in other respects. Lengths of curved fillet welds shall be determined on the basis of their inner dimensions.

5.16.8.3 In addition to complying with the rules for attachment welding given in this standard, the following requirements shall be met:

- a. The joint efficiencies of butt-welds shall be in accordance with 5.23 except that no credit shall be taken for radiographing unless the attachment welding itself can be and is properly radiographed. The strength of butt-welds shall be computed on the area in shear, wherever applicable, or the area in tension using the following stress values multiplied by the joint efficiency:
 1. When the load is perpendicular to the weld, the applicable tension or shear stress values for plate or forged steel given in Table 5-1 or specified in 5.5.5.
 2. When the load is parallel to the weld, 75% of the applicable tension or shear stress values for plates or forged steel given in Table 5-1 or specified in 5.5.5.
 3. For combined perpendicular and parallel loadings around the openings, 87.5% of the applicable tension or shear stress values for plate or forged steel given in Table 5-1 or specified in 5.5.5.

- b. The strength of fillet welds shall be computed by multiplying the area of the minimum section through the throat of the weld by the applicable allowable stress value determined by

combining the following factors: 80% for shear strength of weld metal; an efficiency factor of approximately 85%; and a load factor of 100% for perpendicular loading, 75% for parallel loading, or 87.5% for combined perpendicular and parallel loading:

1. When the load is perpendicular to the weld, 70% of the applicable tension stress value for plate or forged steel given in Table 5-1.
2. When the load is parallel to the weld, 50% of the applicable tension stress value for plate or forged steel given in Table 5-1.
3. For combined perpendicular and parallel loadings around openings, 60% of the applicable tension stress value for plate or forged steel given in Table 5-1.

5.16.9 Minimum Dimensions of Attachment Welds

5.16.9.1 Supplementing the requirements of 5.16.8, the dimensions of reinforcement attachment welds shall comply with the following:

- a. Where the thickness of the thinner of two parts being joined is $\frac{3}{4}$ in. or less, exclusive of corrosion allowance, the dimensions of the welds shall be not less than the requirements indicated in Figure 5-8.
- b. Where the thickness of both parts is greater than $\frac{3}{4}$ in., exclusive of corrosion allowance, the dimensions of the welds shall be not less than the requirements indicated in Figure 5-8 using a value of $\frac{3}{4}$ in. for t_{\min} .

5.16.9.2 Fittings shown in Figure 5-8, Panels s-2, t-2, u-2, and v, that do not exceed 3 in. pipe size may be attached by welds that are exempt from size requirements other than those required by 5.16.8.

5.16.9.3 For fittings attached as shown in Figure 5-8, panel u-3, the depth of the groove weld, t_5 , shall be not less than the thickness of Schedule 160 pipe (see ASME B36.10M).

5.16.10 Telltale Holes In Reinforcing Plates

Except for nozzles located on the underside of a tank bottom that rests directly on the tank grade²⁹ and nozzles with reinforcements that are too narrow to permit compliance with the following provisions, single-thickness reinforcing plates and saddle flanges or integral reinforcing pads on manholes or nozzles attached to the outside of a tank shall be provided with at least one telltale hole with a maximum actual diameter of $\frac{3}{8}$ in. that shall be tapped for a preliminary compressed-air and solution-film test for soundness of attachment welds around the manhole or nozzle and its reinforcement both inside and outside the tank. These telltale holes shall be

²⁹Even in this case, telltale holes should be provided and attachment welds should be tested before the bottom plates are placed in position on the tank grade.

left open when the tank is in service. The surface of the reinforcing plate, saddle flange, or pad adjacent to the tank wall shall be relieved slightly by grinding to be reasonably certain that the test pressure will extend entirely around the nozzle even though the reinforcement may be drawn tightly against the tank wall by the welding.

5.17 REINFORCEMENT OF MULTIPLE OPENINGS

5.17.1 When either of the following conditions occurs for two or more adjacent openings, the opening shall be provided with a combined reinforcement whose strength shall equal the combined strength of the reinforcement that would be required by 5.16 for the separate openings:

- a. The distance between the centers of any two adjacent openings is less than two times their average diameter so that their required areas of reinforcement overlap.
- b. Any two adjacent openings are spaced so that if they are reinforced separately, the distance between the outer edges, or toes, of their reinforcing plate fillet welds (see Footnote 22) or insert welds is (1) less than 6 in. at any point, or if this be larger, (2) eight times the nominal thickness of the fillet weld around the thicker reinforcing plate or eight times the nominal thickness of the insert butt-weld³⁰ for an insert-type connection. In no case shall any portion of a cross section be considered to apply to more than one opening, that is, to be evaluated more than once in a combined area. Curved sections that form the outer boundary of a combined reinforcement shall be connected by straight lines, large-radius reverse curves tangent to the curved sections, or a combination of these two elements; in no case shall there be any re-entrant angles therein.

5.17.2 When two or more adjacent openings will be provided with a combined reinforcement, the minimum distance between the centers of any two of these openings shall preferably be at least 1.5 times their average diameter, and the area of reinforcement between them shall be at least equal to 50% of the total required for these two openings on the cross section being considered.

5.17.3 When two adjacent openings, as considered under 5.17.2, have a distance between centers less than $1\frac{1}{3}$ times their average diameter, no credit for reinforcement shall be given for any of the metal between these two openings.

5.17.4 Any number of closely spaced adjacent openings, in any arrangement, may be reinforced for an assumed opening of a diameter enclosing all such openings.

³⁰Where the periphery weld has been stress-relieved before the welding of the adjacent shell joint, the spacing may be reduced to 6 in. from the longitudinal or meridional joints or 3 in. from circumferential or latitudinal joints provided that in either case the spacing is not less than $2\frac{1}{2}$ times the shell thickness.

5.18 DESIGN OF LARGE, CENTRALLY LOCATED, CIRCULAR OPENINGS IN ROOFS AND BOTTOMS

5.18.1 General

Large openings and reducers of the types illustrated in Figure 5-9, which are centrally located in the roof or bottom of a tank with the axis of the connected cylindrical neck coincident with the axis of revolution of the tank, are not limited as to size and need not be reinforced in accordance with 5.16 if the design of the neck extending from the opening or reducer, the regions of the roof or bottom around the opening, and the transition section between the roof or bottom and the neck meet all applicable requirements of 5.10 and the additional requirements specified in this section. In the case of reducers, the design of the region where the large end meets cylindrical sidewalls shall conform to the requirements of 5.12. A design procedure similar to that specified in 5.12 shall also be used for the region around the large end of a conical transition section that connects to the horizontally disposed surfaces of a roof or bottom instead of to the sidewalls.

5.18.2 Nomenclature

Variables used in Equations 29–32 are defined as follows:

Q = total circumferential force, in lb, acting on a vertical cross section through the juncture between the roof, bottom, or transition section and the neck extending from the opening at one side of the opening,

A_c = net area, in in.², of the vertical cross section of metal required to resist Q , exclusive of all corrosion allowances,

R_2 = length, in in., of the normal to the roof, bottom, or transition section at its juncture with the neck extending from the opening, measured from the surface of the roof, bottom, or transition section to the tank's vertical axis of revolution,

R_n = horizontal radius, in in., of the cylindrical neck extending from the opening at the juncture with the roof, bottom, or transition section,

T_1 = meridional unit force (see 5.10) in the roof, bottom, or transition section at its juncture with the cylindrical neck, in lbf/in. of circumferential arc,

T_2 = corresponding latitudinal unit force (see 5.10) in the roof, bottom, or transition section, in lbf/in. of meridional arc (if the roof or bottom is of double curvature) or per linear in. along

an element of the cone (if the surface is that of a conical frustum),

T_{2n} = circumferential unit force (see 5.10) in the cylindrical neck at its juncture with the roof, bottom, or transition section, in lbf/in. measured along an element of the neck,

α = angle between the direction of T_1 and a vertical line (in a conical surface it is also one-half the vertex angle of the cone),

S_{1s} = maximum allowable stress value for simple tension, in lbf/in.², as given in Table 5-1,

E = efficiency, expressed as a decimal, of the least efficient joint cutting across the section considered (see Table 5-2),

w_h = width, in in., of the roof, bottom, or transition section plate considered to participate in resisting the circumferential force Q ,

w_n = corresponding width, in in., of the participating neck plate,

t_h = thickness, in in., of the roof, bottom, or transition section plate at and near its juncture with the neck extending from the opening, including corrosion allowance,

t_n = corresponding thickness, in in., of the cylindrical neck at and near the juncture described for t_h .

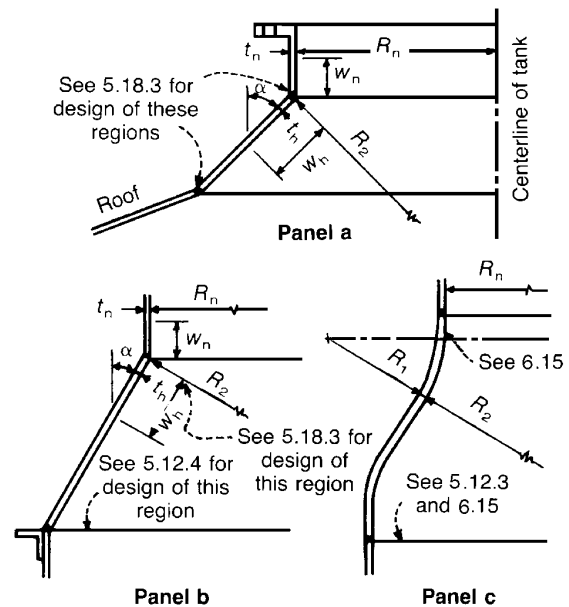

Figure 5-9—Large Head Openings and Conical Shell-Reducer Sections

5.18.3 Knuckle Radius

5.18.3.1 A knuckle radius used for the juncture between the roof, bottom, or transition section and the neck extending from the opening shall be not less than 6% of the diameter of the opening, and the thicknesses required at this location shall be computed in accordance with 5.10. The use of a knuckle radius as small as 6% of the sidewall diameter will frequently require an excessively heavy thickness for the knuckle region. The thickness requirements for this region will be found more reasonable if a larger knuckle radius is used.

5.18.3.2 When a knuckle radius is not used at this location, the stress situation at the juncture is the reverse of that found at the juncture (without a knuckle) between a conical or dished roof and the sidewalls of a cylindrical tank because in this case the horizontal components of the T_1 meridional unit forces in the roof, bottom, or transition section pull outward on the neck extending from the opening and increase the circumferential tensile stresses acting at the juncture. In this case, the walls of the tank and neck of the opening at and near their juncture must be designed to withstand a total circumferential load, Q , on each side of the opening, as computed using the following formula:

$$Q = T_2 w_h + T_{2n} w_n + T_1 R_n \sin \alpha \quad (29)$$

5.18.4 Cross-Sectional Area

The total cross-sectional area of metal required to resist the circumferential force is shown by the following equation:

$$A_c = Q/S_{ts}E \quad (30)$$

The widths of plate available for providing this area and resisting the force Q on each side of the opening shall be computed using the following formulas:

$$w_h = 0.6\sqrt{R_2(t_h - c)} \quad (31)$$

$$w_n = 0.6\sqrt{R_n(t_n - c)} \quad (32)$$

5.19 NOZZLE NECKS AND THEIR ATTACHMENTS TO THE TANK

5.19.1 General

5.19.1.1 Nozzles to be used for pipe connections, hand-holes, or manholes may be constructed of pipe, pipe couplings, forged steel, cast steel, fabricated plate, or other suitable material conforming to the provisions of 4.1, 4.2.2, 4.3, or 4.5.

5.19.1.2 Nozzles may be integral with the tank wall or the wall of another nozzle or with a nozzle cover plate; or, subject

to the limitations stated in these rules, nozzles may be attached directly to the wall of the tank or another nozzle or nozzle cover plate by threading, fusion welding, bearing against the inside of the wall, studding, or bolting.

5.19.1.3 Openings for all nozzles in the wall of the tank or another nozzle shall be reinforced as required by 5.16 or 5.17. Openings in nozzle cover plates need only be reinforced to the extent required by 5.21.1.2, 5.21.1.3, 5.21.2.7, and 5.21.2.8.

5.19.1.4 Nozzles may be attached to a tank by any of the methods shown in Figure 5-8 or by other methods that conform to sound design principles if the nozzle and its attachment in each case meet the requirements of 5.16.

5.19.2 Minimum Thickness of Nozzle Neck

The thickness of a nozzle neck shall be computed for the applicable loadings in 5.4, using allowable stresses as specified in 5.5, and to this thickness shall be added the corrosion allowance. The minimum thickness of nozzle neck to be used shall be at least equal to the required thickness so obtained; in no case shall the net thickness of the nozzle neck, excluding corrosion allowance, be less than the smaller of the following thicknesses:

- The net thickness, excluding corrosion allowance, of the tank wall adjacent to the nozzle, disregarding any added thickness that serves as reinforcement for the opening.
- The thickness of standard-weight pipe (see ASME B36.10M).

5.19.3 Outer Ends of Nozzles

5.19.3.1 The outer ends of nozzles may be flanged, beveled for welding, or threaded except that threaded ends shall not be used unless they are permitted by and meet the requirements of 5.20.4.

5.19.3.2 When a bolting flange is welded to the nozzle neck for its entire thickness, the corner formed by the back of the flange and the nozzle wall shall be provided with a fillet weld. The fillet weld size shall be at least 0.25 times the thickness of the nozzle wall, not including corrosion allowance, except that for relatively thick nozzle walls, the fillet weld shall be not less than 0.25 times the thickness of standard-weight or extra-strong pipe, whichever is nearest to and less than the nozzle wall thickness. This fillet may be machined to a radius of the same size, but in no case shall it be less than $3/16$ in.

5.19.3.3 When a bolting flange is welded to the nozzle neck, but not for its entire thickness, it shall be designed and attached in accordance with 5.20 in this standard and the provisions of Figure 4-4, Appendix 2, in Section VIII of the ASME Code.

5.20 BOLTED FLANGED CONNECTIONS

5.20.1 Bolted flanged connections conforming to ASME B16.5, Class 150, shall be used for connections to external piping and may be used for other flanged connections. Such flanges may be built up by fusion welding if the manufacturer satisfies the inspector, by direct or comparative calculation, that the welded flanges are equivalent in strength to the one-piece flanges that they are intended to replace.

5.20.2 Bolted flanges for external piping connections other than those meeting the requirements of 5.20.1 shall be designed for a pressure of at least 50 lbf/in.² gauge in accordance with the applicable provisions of Section VIII, Appendix 2, of the ASME Code, using for values of S_f and S_n the applicable allowable design stress values given in Table 5-1 of this standard (instead of the allowable design stress values specified in Section VIII of the ASME Code) and limiting the values for S_h , S_r , and S_t as follows:

S_h = longitudinal hub stress, not greater than $1.5S_f$, except that for flanges of the types illustrated in Figures 4-4 (7), (8), (8a), (8b), and (9) in Section VIII, Appendix 2, of the ASME Code, S_h shall not exceed the smaller of $1.5S_f$ or $1.5S_n$,

S_r = radial flange stress, not greater than S_f ,

S_t = tangential flange stress, not greater S_f .

Also, $(S_h + S_r)/2$ shall not be greater than S_f , and $(S_h + s_r)/2$ shall not be greater than S_f . Design stress values for bolts shall not exceed the applicable values given in Table 5-1 in these rules, based on the area at the root of the thread.

5.20.3 Bolted flange connections, other than external piping connections, shall conform to ASME B16.5, Class 150 or shall be designed in accordance with the requirements of 5.20.2 except that they shall be designed for a pressure of at least 15 lbf/in.² gauge or the total pressure, P , on the wall of the tank and the level of the connection, whichever is greater.

5.20.4 Hubbed flanges may be welded to the ends of nozzle necks by any of the methods permitted for circumferential joints in the walls of the tank; the attachment shall conform to the requirement for circumferential joints of the type employed.

5.20.5 Flanges that do not exceed 12-in. pipe size for working pressures up to 50 lbf/in.² gauge or 4 in. pipe size for working pressures above 50 lbf/in.² gauge may be screwed to the end of a nozzle neck if the number of full threads engaged conforms to or exceeds the requirements of ASME B1.20.1.

5.20.6 Bolts and studs shall be at least $1/2$ in. in diameter. If smaller bolts are used, they shall be of alloy steel.

5.21 COVER PLATES

5.21.1 Flat Cover Plates and Blind Flanges

5.21.1.1 The thickness of flat, unstayed cover plates and blind flanges shall be determined by one of the following methods, but shall not be less than $1/2$ in. plus corrosion allowance.

a. Blind flanges that conform to ASME B16.5 and are of the appropriate pressure-temperature ratings and diameters given in the standard, or their equivalent, shall be used when attached by bolting as shown in Figure 5-10, Panels b and c.

b. For sizes and designs not covered by ASME B16.5, the required thickness of flat steel cover plates or blind flanges shall be computed by the following formula using the appropriate value for C :

$$t = d \sqrt{\frac{CP}{s}} + c \quad \text{or} \quad P = \frac{s(t-c)^2}{Cd^2} \quad (33)$$

where

t = minimum required thickness, in.,

d = diameter, in., measured as indicated in Figure 5-10,

C = 0.25 for plates rigidly riveted or bolted to flanges as shown in Figure 5-10, panel a (this applies in these rules to any kind of gasket material),

= 0.30 for plates inserted into the ends of nozzles and held in place by some suitable positive mechanical locking arrangement such as those shown in Figure 5-10, panel d, e, or f if the design of all holding parts against failure by shear, tension, or compression resulting from the end force produced by the pressure is based on a factor of safety of at least four and that threaded joints, if any, in the nozzle wall are at least as strong as they are for standard pipe of the same diameter,

= $0.30 + (1.40 Wh_G/H_G)$ for plates bolted to flanges in such a manner that the setting of the bolts tends to dish the plate, where the pressure is on the same side of the plate as the bolting flange, as shown in Figure 5-10, Panels b and c,

W =flange design bolt load, in lb [see ASME Section VIII, Appendix 2, Paragraph 2-5(e)],

- h_G = radial distance from the bolt-circle diameter to diameter G , in in.,
- H = total hydrostatic end force, in lbs, as defined in ASME Section VIII, Appendix 2, Paragraph 2-3,
- G = diameter, in in., at the location of the gasket load reaction, as defined in ASME Section VIII, Appendix 2, Paragraph 2-3,
- P = design pressure, in lbf/in.² gauge (this shall be at least equal to the total pressure P on the wall of the tank at the level where the cover plate is located or shall be 15 lbf/in.² gauge, whichever is greater),
- s = maximum allowable stress value, S_{TS} , in lbf/in.², as given in Table 5-1,
- c = corrosion allowance, in in.

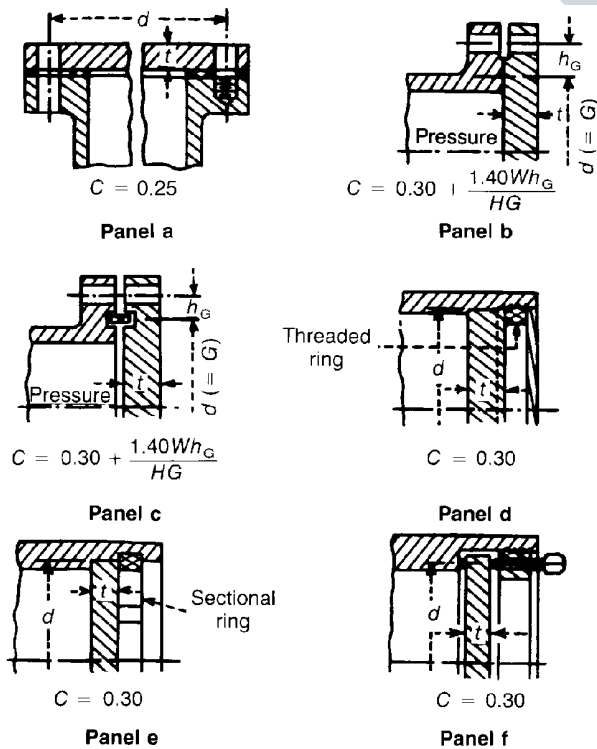

Note: The illustrations above are diagrammatic only. Other designs, which meet the requirements of 5.21, will be acceptable.

Figure 5-10—Acceptable Types of Flat Heads and Covers

5.21.1.2 Unreinforced openings up to and including 2-in. pipe size are permissible in flat cover plates without increasing the plate thickness if the edges of these openings are not closer to the center of the plate than one-fourth the diameter d in Figure 5-10. When this condition is not met, the plate thickness shall be increased by 40% of the thickness required in a solid plate after the loss of corrosion metal. The solid-plate thickness shall be determined by deducting the corrosion allowance from the thickness computed using Equation 33.

5.21.1.3 Openings that do not exceed 50% of dimension d shown in Figure 5-10 may be made in flat cover plates if these openings are reinforced in accordance with 5.16 as though the cover plates were dished to the form of a spherical segment having a radius equal to diameter d . However, the reinforcement added to the cover plate shall compensate for not less than 50% of the cross section of the metal removed for the opening in the cover plate. When the maximum diameter of the opening in the flat cover plate exceeds 50% of dimension d shown in Figure 5-10, the cover plate shall be designed as a flange in accordance with the rules for bolted flanges given in 5.20 of this standard and in ASME Section VIII, Appendix 2.

5.21.2 Spherically Dished Cover Plates

5.21.2.1 The variables used in the formulas in this section and Figure 5-11 are defined as follows:

- t = minimum required thickness of the cover plate after forming, including corrosion allowance, in in.,
- t_f = flange thickness, including corrosion allowance, in in.,
- A = outside diameter of flange, in in.,
- B = inside diameter of flange, in in.,
- C = bolt-circle diameter, in in.,
- D = inside diameter of cover-plate skirt, in in.,
- L = inside spherical or crown radius, in in.,
- r = inside knuckle (torus) radius, in in.,
- P = design pressure, in lbf/in.² gauge (shall be at least equal to the total pressure P on the wall of the tank at the level where the cover plate is located or 15 lbf/in.² gauge, whichever is greater),
- s = maximum allowable stress value, S_{TS} , in lbf/in.², as given in Table 5-1,

M_o = total moment determined as for loose-type flanges (see ASME Section VIII, Appendix 2, Paragraph 2-6) except that, for cover plates of the

type shown in Figure 5-10, panel d, a moment $H_r h_r$ shall be included (that may add or subtract),

H_r = radial component of the membrane load in the spherical segment = $H_D \cot \beta_1$,

h_r = level arm of force H_r around the centroid of the flange ring, in lb.

5.21.2.2 The radius of dish, L , in tori spherical heads shall not exceed the outside diameter of the head skirt, and the knuckle radius, r , shall be not less than 6% of the outside diameter (see Figure 5-11, panel a).

5.21.2.3 In ellipsoidal heads, the inside depth of the head minus the width of the skirt shall be not less than $1/4$ the inside diameter of the head skirt (see Figure 5-11, panel a).

5.21.2.4 Cover-plate heads of hemispherical shape need not have an integral skirt, but where a skirt is provided, the juncture between the skirt and the spherically dished portion of the head shall not project more than $1/2$ in. beyond the weld between the head and the back face of the cover-plate flange unless the thickness of the skirt is at least equal to the thickness required for a seamless cylindrical shell of the same diameter.

5.21.2.5 The thickness of circular dished cover plates with bolting flanges, concave to the pressure and conforming to the several types illustrated in Figure 5-11, shall be designed in accordance with the following requirements, but shall not be less than $1/2$ in. plus corrosion allowance.

a. For cover plates of the types shown in Figure 5-11, panel a, the thickness of the plate, t , shall be determined by the following application equation:

For torispherical heads,

$$t = (0.885PL/s) + c \quad (34)$$

For 2:1 ellipsoidal heads,

$$t = (PD/2s) + c \quad (35)$$

For hemispherical heads,

$$t = (PD/4s) + c \quad (36)$$

The cover plate flange thickness and bolting for these types of cover plates shall comply at least with the applicable requirements of Section VIII, Appendix 2, Figure 4-4, of the ASME Code and shall be designed in accordance with the provisions of 5.20.2.

b. For cover plates of the type shown in Figure 5-11, panel c, the thickness of the plate and flanges shall be determined by the following applicable equation:

For the thickness of the cover plate,

$$t = (5PL/6s) + c \quad (37)$$

For the flange thickness using a ring gasket,

$$t_f = \sqrt{\frac{M_o}{s} \left[\frac{A+B}{B(A-B)} \right]} \quad (38)$$

For the flange thickness using a full-face gasket,

$$t_f = 0.6 \sqrt{\frac{P[B(A+B)(C-B)]}{s(A-B)}} \quad (39)$$

(The radial components of the membrane load in the spherical segment are assumed to be resisted by the flange.)

c. For cover plates of the type shown in Figure 5-11, panel b, the plate thickness for a ring gasket is determined using the following equation:

$$t = Q \left[1 + \sqrt{1 + \frac{7.5M_o}{PQBL}} \right] + c \quad (40)$$

The plate thickness for a full-face gasket is determined using the following equation:

$$t = Q \left[1 + \sqrt{1 + \frac{3(C-B)B}{QL}} \right] + c \quad (41)$$

where

$$Q = \left(\frac{P}{s} \right) \left(\frac{L}{4} \right) \left[\frac{1}{1 + 6 \left(\frac{C-B}{C+B} \right)} \right]$$

In no case shall the plate thickness be less than the value determined using the following equation:

$$t = (5PL/6s) + c$$

d. For cover plates of the type shown in Figure 5-11, panel d, the thickness of the cover plate is determined using the following equation:

$$t = (5PL/6s) + c \quad (42)$$

(The factor $5/6$ in this case includes an allowance of $E = 0.8$ at the circumferential weld.)

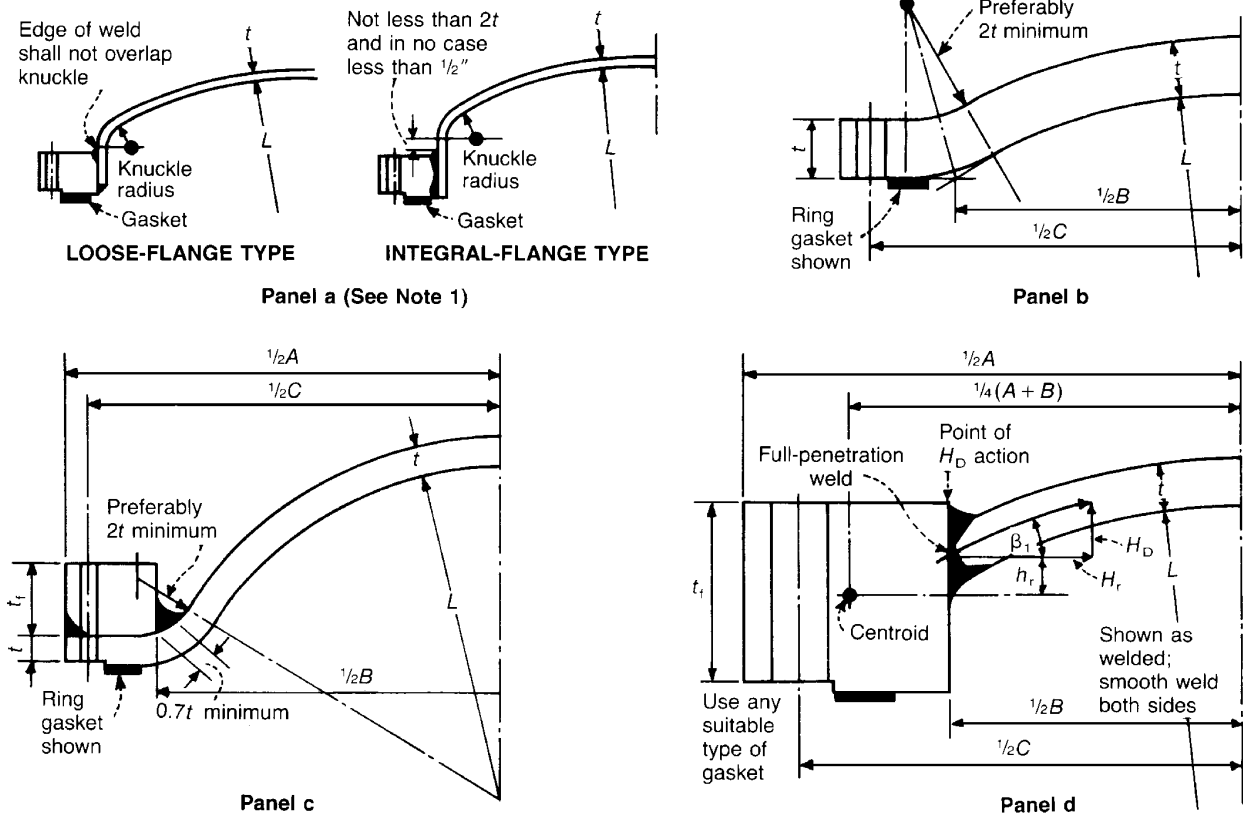

Notes:

1. Ellipsoidal or hemispherical heads may also be used in the above type of cover plate.
2. In no case shall the radius of dish, L , be greater than the inside of the cover-plate bolting flange (Dimension B).

Figure 5-11—Spherically Dished Steel Plate Covers with Bolting Flanges

The flange thickness is determined using the following equation:

$$t_f = F \left[1 + \sqrt{1 + \frac{J}{F^2}} \right] + c \quad (43)$$

where

$$F = \frac{PB\sqrt{4L^2 - B^2}}{8_s(A - B)}$$

$$J = \left(\frac{M_o}{sB} \right) \left[\frac{(A + B)}{(A - B)} \right]$$

Note: Inasmuch as $H_r h_r$ may add to or subtract from the total moment determined as for loose-type flanges, the moment in the flange ring when the internal pressure is zero may be the critical loading for the flange design (see 5.20.2).

5.21.2.6 The thicknesses of circular dished cover plates with bolting flanges, convex to the pressure and conforming

to the several types illustrated in Figure 5-11, shall be designed in accordance with the requirements of 5.21.2.5 except that the pressure, P , used for computing the thickness of the cover plate, t , shall be not less than $1.67P_v$, where P_v is defined as follows:

P_v = maximum unbalanced pressure, in lbf/in.^2 , on the convex side of the plate during operation; however, if the pressure is 15 lbf/in.^2 or less, P_v shall be 15 lbf/in.^2 or 25% more than the maximum possible unbalanced pressure, whichever is the smaller.

The minimum thickness shall be as calculated plus corrosion allowance or $1/2 \text{ in.}$ plus corrosion allowance, whichever is greater.

Moreover, if the net plate thickness, $t - c$, determined previously in this paragraph, is found to be less than or equal to 0.01 times the inside diameter of the cover-plate flange, a check computation shall be made to determine the thickness required by Equation 44. The plate shall be made not less than the thickness computed using the following equation:

$$t = \frac{4L_c\sqrt{P_v}}{5350} + c \quad (44)$$

where

L_c = inside crown radius for dished (torispherical) and hemispherical heads, in in.; or $0.9D$ for 2:1 ellipsoidal heads, in which D is the inside diameter of the head, in in.

5.21.2.7 Openings up to and including 2-in. pipe size may be made in the spherical segment of a dished cover plate without increasing the thickness of the segment if the opening attachment is entirely clear of the fillets joining the spherical segment to the flange of the cover plate.

5.21.2.8 Openings greater than 2-in. pipe size may be made in the spherical segment of a dished cover plate if these openings are reinforced in accordance with 5.16 or 5.17.

5.22 PERMITTED TYPES OF JOINTS

5.22.1 Definitions

5.22.1.1 The information in 5.22.1.2 through 5.22.1.6 covers fusion-welded joints permitted by this standard. (See Table 5-2 for limitations of joints.)

5.22.1.2 Terms relating to weld joints shall be as defined in Section IX of the ASME Code and the following:

- a. An angle joint is one located between two members located in intersecting planes between zero (a butt joint) and 90° (a corner joint).
- b. A slot weld is the same as a plug weld except that it is made through an elongated hole that has semicircular ends. Fillet-welded holes should not be construed as a plug or slot weld.

5.22.1.3 The reverse side of a double-welded butt joint shall be prepared by chipping, grinding, or melting-out to ensure sound metal at the base of the weld metal first deposited before weld metal is applied from the reverse side. This operation shall be done to ensure complete penetration and proper fusion in the final weld.

Note: The proceeding requirements of this section are not intended to apply to any welding procedure by which proper fusion and complete penetration are otherwise obtained and by which unacceptable defects at the base of the weld are avoided.

5.22.1.4 If the backing strips for single-welded joints are not removed, all ends of strips abutting (including a T-junction) shall be joined with a full-penetration weld. A backing strip need not be removed after the weld is completed unless the joint is to be radiographed and the back-

ing-strip image would interfere with interpretation of the resultant radiographs.

5.22.1.5 Double and single lap-joints shall have full-fillet welds, the size of which is equal to the thinner member joined. The surface overlap shall be not less than four times the thickness of the thinner plate, with a 1 in. minimum.

5.22.1.6 When full-penetration welds are specified for the circumferential joints of diametrical transitions, angle joints 30 degrees or less meet this requirement. All other requirements for a butt-welded joint apply.

5.22.2 Size of Weld

5.22.2.1 Groove Weld

The size of a groove weld is determined by the joint penetration, which is the depth of chamfering plus the root penetration when root penetration is specified.

5.22.2.2 Fillet Weld

5.22.3 For equal-leg fillet welds, the leg length of the largest isosceles right triangle that can be inscribed within the fillet-weld cross section determines the size of the weld. For unequal-leg fillet welds, the leg length of the largest right triangle that can be inscribed within the fillet-weld cross section determines the size of the weld.

5.22.4 Throat of a Fillet Weld

The throat of a fillet weld is the shortest distance from the root of the fillet weld to its face. For a convex fillet weld, the hypotenuse of the triangle which has the greatest area that can be inscribed within the fillet-weld cross section is considered the face.

5.22.5 Heads Convex To Pressure

Heads convex to pressure for the purpose of sealing manways may be attached to the manway neck using single full-fillet lap joints without plugs in accordance with Figure 5-8, panel w, and the limitations of Table 5-2.

5.23 WELDED JOINT EFFICIENCY

5.23.1 General

The efficiency of a welded joint is a joint efficiency factor used in design computation or in computations that relate the strengths of welded structures. The joint efficiency factor is based on the assumption that the welds may contain defects within the limits permitted by these rules or may otherwise be of a quality somewhat below that of the parent material. Permissible joint efficiency factors are given in Table 5-2, where the factor is expressed as a percent; in computations it is expressed as a decimal.

In the case of butt-welded joints and full-fillet lap-welded joints, the joint efficiency factor is assumed to exist between the working strength of the joint and the working strength of the solid plate.

In the case of fillet welds evaluated as specified in 5.16.8.3, item b, plug welds, and other attachment welding, the joint efficiency factor is assumed to exist between the working strength of the area of weld involved in the computations and the working strength of the same area of solid parent metal.

5.23.2 Maximum Joint Efficiencies

The maximum joint efficiencies permitted in the design of tanks or tank parts fabricated by an arc-welding process and the limitations on the use of the various types of these joints are given in Table 5-2.

5.23.3 Welded Pipe Joint Efficiencies

The allowable unit tensile stress values given in Table 5-1 for welded steel pipe reflect a welded joint efficiency factor of 0.80 for the longitudinal joints in that material. No further reduction for joint efficiency needs to be made in those joints.

The low-pressure operating conditions for which these tanks are used will often make the thickness of pipe materials, as determined by the cylindrical shell formula, of little significance; the girth joints that are subject to piping strains, including even moderate temperature effects, may be the controlling factor. The joint efficiencies for such girth joints shall be taken from Table 5-2, but in applying these efficiencies to the allowable stress values in Table 5-1 for welded pipe, allowance may be made for the fact that the allowable values already reflect a joint efficiency factor of 0.80, as stated in this paragraph.

5.24 PLUG WELDS AND SLOT WELDS

5.24.1 Plug welds and slot welds may be used in conjunction with other forms of welds for joints in structural attachments and in reinforcements around openings. They shall be sized and spaced properly to carry their portion of the load but shall not in any case be considered to take more than 30% of the total load to be transmitted by the joint of which they form a part.

5.24.2 The diameter of plug-weld holes and the width of slot-weld holes in members whose thickness is $\frac{1}{2}$ in. or less shall be not less than $\frac{3}{4}$ in.; for members more than $\frac{1}{2}$ in. in thickness, the diameter, or width, of such holes shall be not less than the thickness of the member through which the hole is cut plus $\frac{1}{4}$ in.

5.24.3 Except as otherwise provided in 5.24.2, the diameter, or width, of the holes shall not exceed twice the thickness of the member through which the hole is cut plus $\frac{1}{4}$ in. In no case, however, does the dimension need to be greater than $2\frac{1}{4}$ in.

5.24.4 Plug-weld and slot-weld holes shall be completely filled with weld metal when the thickness of the member through which the hole is cut is $\frac{5}{16}$ in. or less. For thicker members, the holes shall be filled to a depth of at least one-half the thickness of the member or one-third the hole diameter, or width, whichever is greater, but in no case shall they be filled less than $\frac{5}{16}$ in. Fillet-welded holes are not considered to be plug welds or slot welds.

5.24.5 The effective shearing area of plug welds shall be considered to be the area of a circle whose diameter is $\frac{1}{4}$ in. less than the diameter of the hole at the fraying surface. The effective shearing area of the semicircular ends of slot welds shall be computed on a comparable basis, and the effective area between the centers of the semicircular ends shall be taken as the product of the distance between such centers and a width that is $\frac{1}{4}$ in. less than the width of the slot at the fraying surface.

5.25 STRESS RELIEVING³¹

5.25.1 Definition

Stress-relief heat treatment is the uniform heating of a structure or portion of a structure to a sufficient temperature below the critical range to relieve the major portion of the residual stresses, followed by uniform cooling.

5.25.2 Field Stress Relief

A tank built according to the rules of this standard is not usually thermally field stress relieved after erection because its size and weight do not permit adequate support at the temperature required for stress relieving. When a tank is not to be field stress relieved, the field-welding procedure shall be one that (a) has been proven satisfactory by experience or adequate experiments and (b) will minimize locked-up residual stresses, which are thought to be one of the main causes of cracking in or adjacent to welds (see 6.19 and H.4).

5.25.3 Wall Thickness

Tank sections that have a nominal thickness of wall plate greater than $1\frac{1}{4}$ in.³² at any nozzle or other welded attachment and nozzle necks whose thickness at any welded joint therein exceeds $(D + 50)/120$ shall be thermally stress relieved after welding. Thickness of compression rings as defined in 5.12 (examples shown in Figure 5-6) are not considered in the determination of thermal stress relief require-

³¹Any proposed application of stress-relieving requirements and the procedures to be followed in each case should be agreed upon by the purchaser and the manufacturer. Peening may be done if it is part of the welding procedure and is approved by the purchaser (see 6.7 and 6.19).

³²For P-1 and P-12B-Subgroup 2 materials, the $1\frac{1}{4}$ in. thickness may be increased to $1\frac{1}{2}$ in. provided that a minimum preheat temperature of 200°F is maintained during welding.

ments. In this formula diameters less than 20 in. shall be assumed to be 20 in. When thermal stress relief cannot be applied to welded assemblies of these parts after erection, all such assemblies, particularly around openings and support attachments, shall be made in the shop and shall be thermally stress relieved before shipment.

5.25.4 Fillet-Weld Attachments

The requirement of 5.25.3 does not apply to fillet welds used for small nozzle or lug attachments when the welds have a size that is a) no greater than $\frac{1}{2}$ in. for welds on a flat surface or circumferential welds on a cylindrical or conical surface or b) no greater than $\frac{3}{8}$ in. for longitudinal welds on surfaces of the latter two shapes or for any welds on surfaces that have double curvature.

04 | 5.26 RADIOGRAPHIC/ULTRASONIC EXAMINATION

5.26.1 General

Examination for the quality of butt welds where required by 5.26 shall be made using either the radiographic method specified in 7.15.1 or alternatively, by agreement between the purchaser and the manufacturer, using ultrasonic examination in lieu of radiography as specified in 7.15.3.1. When the term "examination" is used in 5.26, it shall be understood to refer to radiographic or ultrasonic examination.

04 | Note: Ultrasonic testing (UT) and radiography (RT) are complementary methods. UT can detect some types of flaws better than RT and vice versa. Therefore, the acceptance criteria provided in API Std 620 for the two methods differ. In the case of RT, all weld flaws require characterization as their type (e.g., crack, incomplete fusion, rounded indication, etc.) and acceptance criteria vary according to the characterization. RT acceptance criteria in API Std 620 are based on definitions of good workmanship. In the case of UT, flaw characterization by type or shape is not required (except for results of supplemental MT/PT). Rather the sizing of both the length and height of flaws is emphasized. The UT acceptance criteria provided in Appendix U are based on fracture mechanics and assume that any flaw may have crack-like characteristics.

5.26.2 Definitions

Radiography is the process of passing electromagnetic radiation, such as X-rays or Gamma rays through an object and obtaining a record of its soundness upon a sensitized film.

Ultrasonic examination is a method of detecting imperfections in material by passing ultrasonic waves through the material and interpreting the reflected and/or diffracted waves.

04 | 5.26.3 Examination Required by Wall Thickness

Complete examination is required for all double-welded butt joints wherever the thinner of the plates or the tank-wall thicknesses at the joint exceed $1\frac{1}{4}$ in. and the joint is subjected to tension stress greater than 0.1 times the specified minimum tensile strength of the material.

5.26.4 Examination Required for Joint Efficiency

04 | 5.26.4.1 The increased joint efficiency allowed in Table 5-2 for completely radiographed joints in a tank or tank sections may be used in the design calculations if the conditions described in 5.26.4.2 and 5.26.4.3 are met.

04 | 5.26.4.2 Main joints (all longitudinal and circumferential joints in the tank wall or meridional and latitudinal joints in walls of double curvature) are of the butt-welded type except for nozzle, manhole, and support attachment welds to the tank wall, which need not be of the butt-welded type.

04 | 5.26.4.3 All butt-welded joints described in 5.26.4.2 are examined throughout their length, as prescribed in 7.15, except under the following conditions:

a. When parts of tanks do not require complete examination (see 5.26.3). In this case, circumferential joints in cylindrical or conical surfaces need to be prepared and examined for a distance of only 3 in. on each side of any intersection with a longitudinal joint. All joints in a spherical, torispherical, or ellipsoidal shape or in any other surface of double curvature shall be considered longitudinal joints. For similar reasons, the juncture without a knuckle between a conical or dished roof or bottom, and cylindrical sidewalls and the circumferential joints without a knuckle at either or both ends of a transition section shown in Figure 5-9 shall be examined if the adjacent longitudinal joints are to receive credit for being radiographed.

b. When welded butt joints in nozzle necks do not require complete examination (see 5.26.3). This provision applies to their fabrication and is not necessarily the form of attachment to the tank.

5.26.5 Exemptions

04 | Spot or full examination is not mandatory on tank bottoms that are uniformly supported throughout (for example, concrete slab or compacted sand) or on components that have a design thickness controlled by compressive stress only.

5.27 FLUSH-TYPE SHELL CONNECTION

5.27.1 Cylindrical-Sidewall, Flat-Bottom Tanks

5.27.1.1 A low-pressure tank of this configuration may have flush-type connections at the lower edge of the shell. These connections can be made flush with the flat bottom under the conditions described 5.27.1.2 through 5.27.1.4.

5.27.1.2 The design pressure for the gas vapor space of the tank shall not exceed 2 lbf/in.^2 gauge.

5.27.1.3 The sidewall uplift from the internal design and test pressures, wind, and earthquake loads shall be counteracted, as noted in 5.11.2, in such a manner that no uplift will occur at the cylindrical sidewall, flat-bottom junction.

Table 5-10—Dimensions of Flush-Type Shell Connections (Inches)

Class 150 Nominal Flange Size	Height of Opening, h	Width of Opening, b	Arc Width of Sidewall Reinforcing Plate, W	Upper Corner Radius of Opening, r_1	Lower Corner Radius of Sidewall Reinforcing Plate, r_2
8	8	8	38	4	14
12	12	12	52	6	18
16	12	20	64	6	18
18	12	22	66	6	18
20	12	25	69	6	18
24	12	36	89	6	18

5.27.1.4 The longitudinal or meridional membrane stress in the cylindrical sidewall at the top of the opening for the flush-type connection shall not exceed $1/10$ of the circumferential design stress in the lowest sidewall course that contains the opening.

5.27.2 Dimensions and Details

5.27.2.1 The dimensions and details of the connection shall conform to Table 5-10, Figure 5-12, and the rules specified in this section.

5.27.2.2 The maximum width, b , of the flush-type connection opening in the cylindrical sidewall shall not exceed 36 in.

5.27.2.3 The maximum height, h , of the opening in the cylindrical sidewall shall not exceed 12 in.

5.27.2.4 The thickness of the sidewall plate in the clean-out opening assembly shall be at least as thick as the adjacent sidewall plate in the lowest sidewall course.

5.27.2.5 The thickness of the sidewall reinforcing plate shall be of the same thickness as the sidewall plate in the flush connection assembly.

5.27.2.6 The thickness, t_a , of the bottom transition plate in the assembly shall be $1/2$ in. minimum, or when specified, the thickness of the bottom annular plate.

5.27.3 Stress Relieving

The reinforced connection shall be completely pre assembled into a sidewall plate. The completed assembly, including the sidewall plate that contains the connections, shall be thermally stress relieved at a temperature of 1100°F – 1200°F for a period of 1 hour per in. thickness of sidewall-plate thickness, t_d .

5.27.4 Reinforcement

5.27.4.1 The reinforcement for a flush-type sidewall connection shall conform to the rules described in 5.27.4.2 through 5.27.4.6.

5.27.4.2 The cross-sectional area of the reinforcement over the top of the connection shall be not less than the value determined using the following equation:

$$K_1ht/2$$

where

K_1 = area coefficient, as given in Figure 5-13,

h = greatest vertical height of the clear opening, in in.,

t = thickness, in in. of the sidewall course in which the connection is located, exclusive of corrosion allowance.

5.27.4.3 The reinforcement in the plane of the sidewall shall be provided within a height, L , above the bottom of the opening. L shall not exceed $1.5h$ except that L minus h shall be not less than 6 in. for small openings. Where this exception results in a height, L , greater than $1.5h$, only that portion of the reinforcement within a height of $1.5h$ shall be considered effective.

Note: L = height of the shell reinforcing plate, in in.

5.27.4.4 The required reinforcement may be provided by any one or by any combination of the following:

- The shell reinforcing plate.
- Any thickness of the shell plate in the assembly greater than the thickness of the adjacent plates in the lowest sidewall course.
- That portion of the neck plate that has a length equal to the thickness of the reinforcing plate.

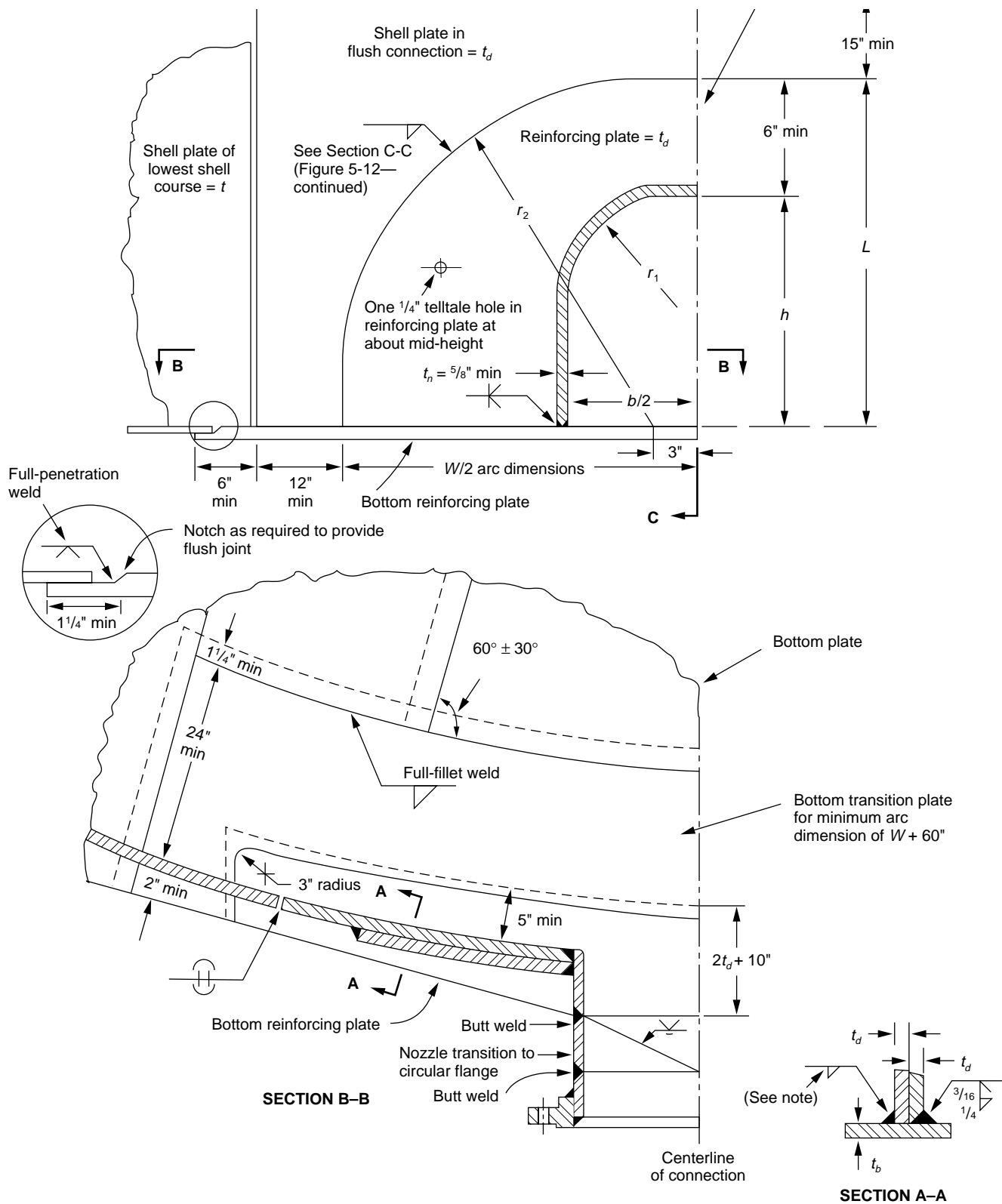

Note:

1. The thickness of the thinner plate joined with a maximum of $1/2$ inch.

Figure 5-12—Part 1—Flush-Type Sidewall Connection

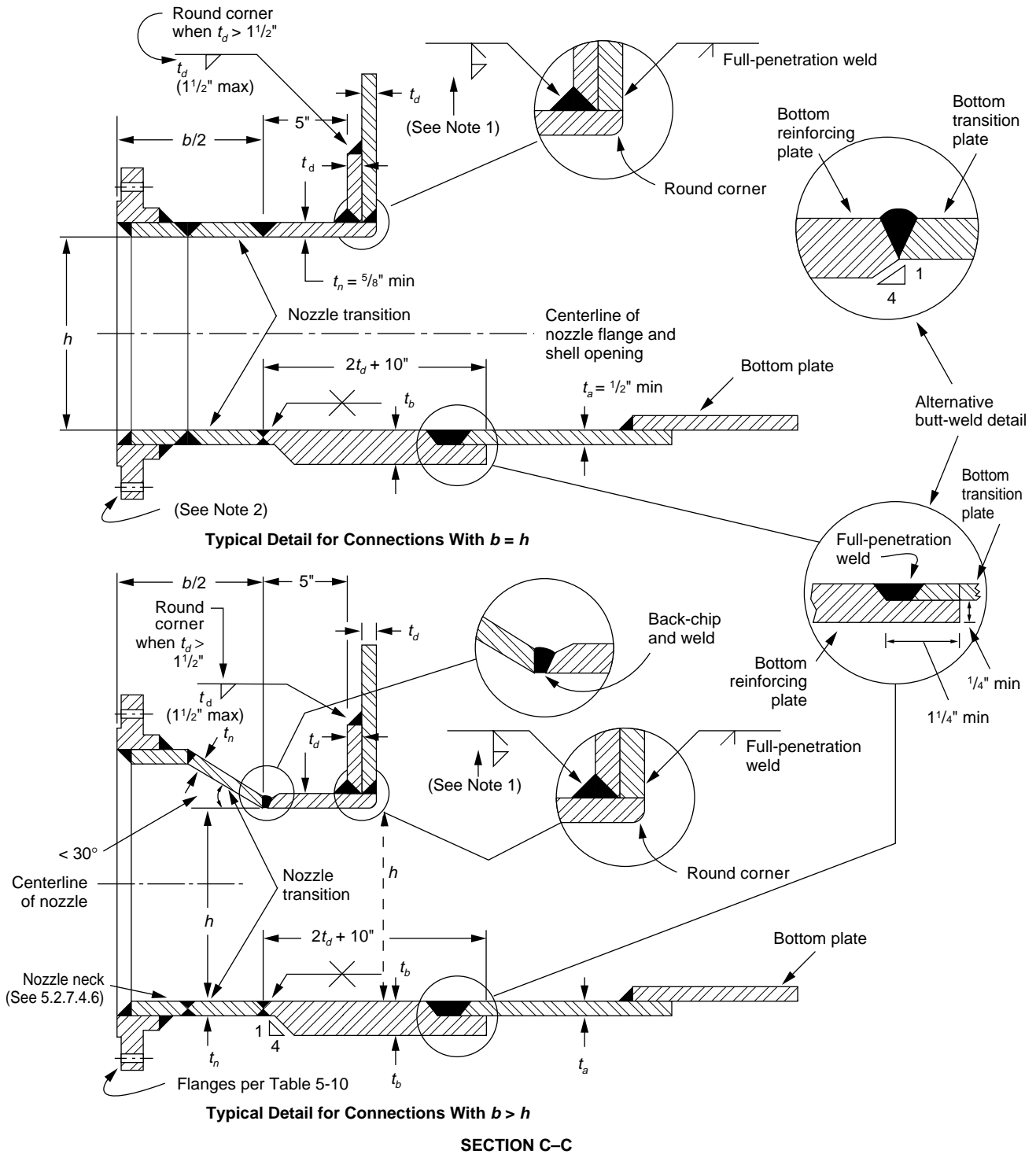

Notes:

1. The thickness of the thinner plate joined with a maximum of 1/2 inch.
2. Flanges in sizes 1 1/2–24 inches shall conform to ASME B16.5. Flanges in sizes larger than 24 inches shall conform to ASME B16.47.

Figure 5-12—Part 2—Flush-Type Sidewall Connection

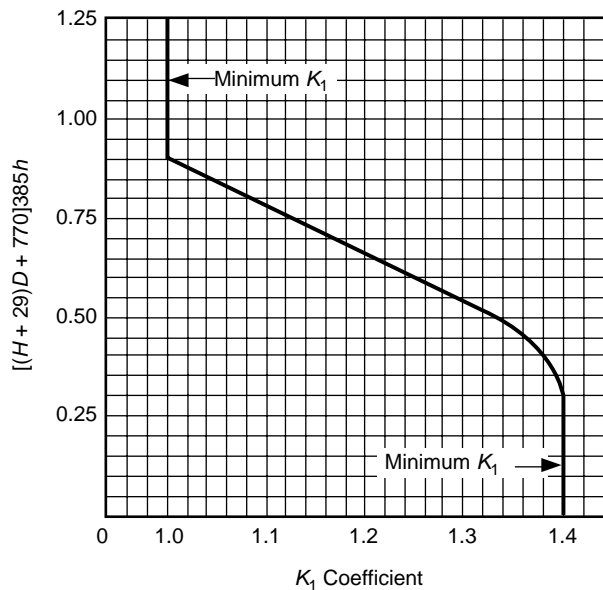

K_1 = Area coefficient for determining minimum reinforcement of a flush-type connection.
 H = Height of tank, in feet.
 D = Inside diameter of tank, in feet.

Figure 5-13—Design Factors for Flush-Type Connections

5.27.4.5 The width of the tank-bottom reinforcing plate at the centerline of the opening shall be 10 in. plus the combined thickness of the sidewall plate in the flush connection assembly and the sidewall reinforcing plate. The thickness of the bottom reinforcing plate, t_b , in in., shall be calculated using the following equation.

$$t_b = \frac{h^2}{14,000} + \frac{b}{280} \sqrt{H}$$

where

h = vertical height of clear opening, in in.,
 b = horizontal width of clear opening, in in.,
 H = height of tank, in ft.

The minimum thickness of the bottom reinforcing plate, t_b , shall be $5/8$ in. for $H = 48$; $1^{1/16}$ for $H = 56$; and $3/4$ in. for $H = 64$.

5.27.4.6 The thickness of the nozzle transition piece and the nozzle neck, t_n , shall be a minimum of $5/8$ in. External loads applied to the connection may require that t_n be greater than $5/8$ in.

5.27.5 Material Requirements

All materials in the flush-type shell connection assembly shall conform to the requirements of Section 4. The plate

materials of the sidewall containing the assembly, the sidewall reinforcing plate, the nozzle neck attached to the sidewall, the transition piece, and the bottom reinforcing plate shall meet the impact test requirements of 4.2.5 at design metal temperatures for the respective thickness involved. Notch toughness evaluation for the bolting flange and the nozzle neck attached to the bolting flange shall be based on the governing thickness as defined in 4.3.5.3 and used in Figure 4-2. Additionally, the yield strength and tensile strength of the sidewall plate in the flush-type shell connection and the sidewall reinforcing plate shall be equal to or greater than the yield strength and tensile strength of the adjacent sidewall of the lowest shell course plate.

5.27.6 Connection Transition

The nozzle transition between the flush connection in the shell and the circular pipe flange shall be designed in a manner consistent with the rules given in this standard. Where the rules do not cover all details of design and construction, the manufacturer shall provide details of design and construction that will be as safe as those provided by the rules of this standard (see 5.1.1).

5.27.7 Anchorage

Where anchoring devices are used to resist the sidewall uplift, they shall be spaced so that they will be located immediately adjacent to each side of the reinforcing plates around the opening, while still providing the required anchorage for the tank sidewall.

5.27.8 Allowance for Sidewall or Piping Movement

Adequate provision shall be made for free movement of connected piping to minimize thrusts and moments applied to the sidewall connection. Allowance shall be made for the rotation of the sidewall connection caused by the restraint of the tank bottom to the sidewall expansion from stress and temperature as well as for thermal and elastic movement of the piping. In double-wall tanks, any insulation or other material shall not restrain or tend to increase the movement of the sidewall connection. The rotation of the sidewall connection is illustrated in Figure 5-14.

5.27.9 Foundation

The foundation in the area of a flush-type connection shall be prepared to support the bottom reinforcing plate of the connection. The foundation for a tank that rests on a concrete ringwall shall provide a uniform support for the bottom reinforcing plate as well as the remaining bottom plate under the tank sidewall. Different methods of supporting the bottom reinforcing plate under a flush-type connection are shown in Figure 5-14.

5.27.10 Nozzle Spacing

Flush-type connections may be installed using a common reinforcing pad. However, when this type of construction is employed, the minimum distance between nozzle centerlines shall be not less than $1.5(b_1 + b_2 + 2.5)$ in. or 2 ft, whichever is greater. The dimensions b_1 and b_2 shall be obtained from Table 5-10, Column 3, for the respective nominal flange sizes. Adjacent sidewall flush-type connections that do not share a common reinforcing plate shall have at least a 36 in. clearance between adjacent edges of their reinforcing pads.

5.27.11 Weld Examination

All longitudinal butt-welds in the nozzle neck and transition piece if any, and the first circumferential butt-weld in the neck closest to sidewall, excluding neck to flange weld shall receive 100% radiographic examination. The nozzle-to-tank sidewall and reinforcing plate welds and the sidewall-to-bottom reinforcing plate welds shall be examined their entire length using magnetic-particle examination. This magnetic-particle examination shall be performed on the root pass, on every $\frac{1}{2}$ in. of deposited weld metal while the weld is being made, and on the completed weld.

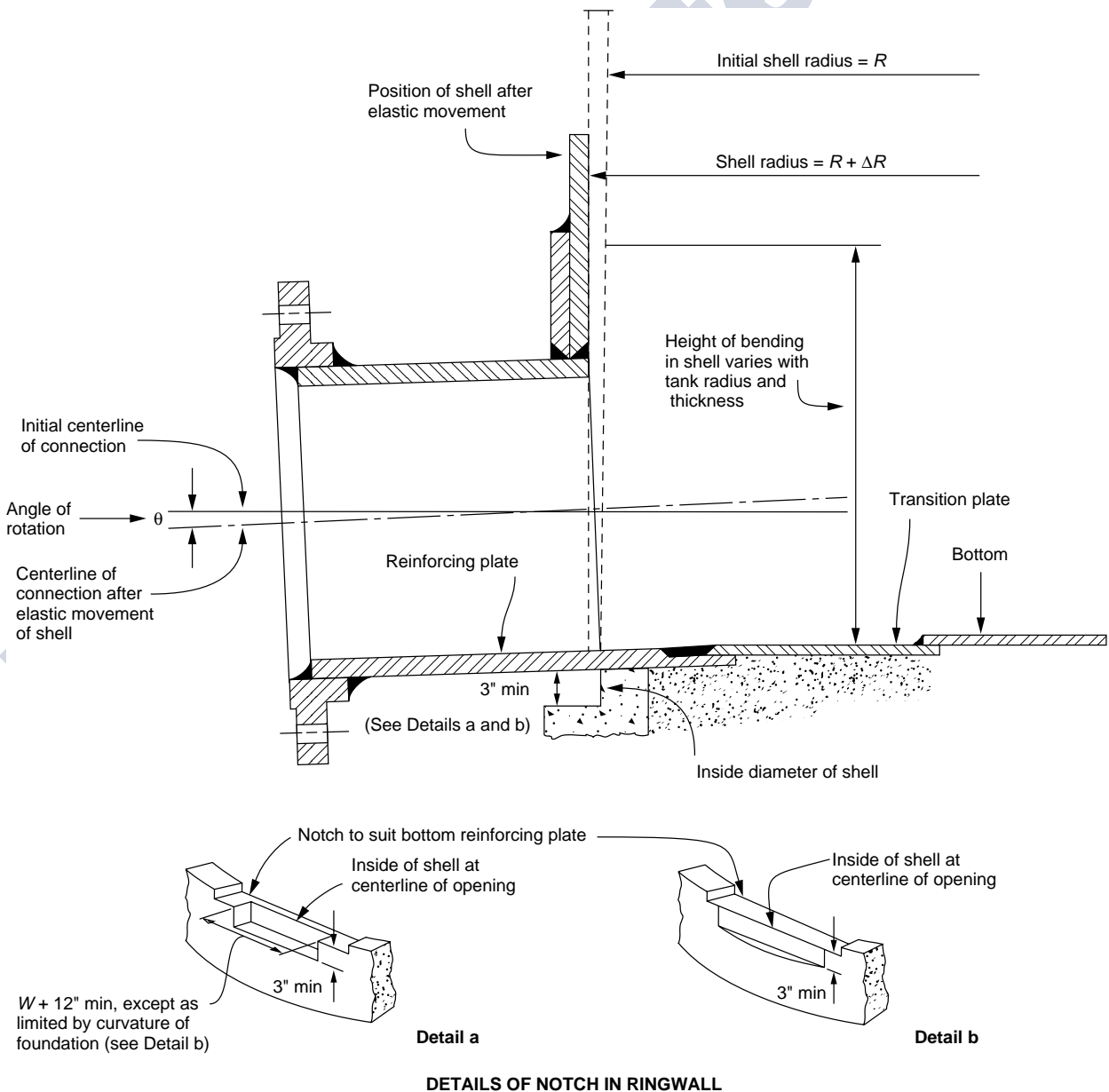

Figure 5-14—Rotation of Sidewall Connection

**For Committee
Use Only**

SECTION 6—FABRICATION

6.1 GENERAL

This section covers details in fabrication practices that are considered essential in constructing large, welded tanks designed according to the rules in this standard.

6.2 WORKMANSHIP

6.2.1 All work of fabricating API Std 620 tanks shall be done in accordance with this standard and with the permissible alternatives specified in the purchaser's inquiry or order. The workmanship and finish shall be first class in every respect and subject to the closest inspection by the manufacturer's inspector, whether or not the purchaser waives any part of the inspection.

6.2.2 When material requires straightening, the work shall be done by pressing or another non injurious method prior to any layout or shaping. Heating or hammering is not permissible unless the material is heated to a forging temperature during straightening.

6.3 CUTTING PLATES

6.3.1 Plates, edges of heads, and other parts may be cut to shape and size by mechanical means such as machining, shearing, and grinding or by gas or arc cutting. After gas or arc cutting, all slag and detrimental discoloration of material that has been molten shall be removed by mechanical means before further fabrication or use.

6.3.2 All holes made in the tank wall, the edges of which are not to be fused by welds, should preferably be tool-cut. If openings are manually flame-cut, the edges to remain unwelded shall be tool-cut or ground smooth (see Figure 5-8 for finish of unwelded exposed edges).

6.4 FORMING SIDEWALL SECTIONS AND ROOF AND BOTTOM PLATES

All plates for sidewall sections shall be shaped to suit the curvature of the tank and the erection procedure according to Table 6-1.

If curved, roof and bottom plates shall be formed to the required shape by any process that will not unduly impair the mechanical properties of the material.

6.5 DIMENSIONAL TOLERANCES

6.5.1 General

Tank walls subject to membrane stresses that are more than $\frac{1}{3}$ of the allowable design stress under service conditions shall conform to the tolerances described in 6.5.2 through 6.5.6. The number and frequency of measurements

Table 6-1—Sidewall Plate Forming Schedule

For Steel and Stainless Steel Plates	
Nominal Plate Thickness mm (in.)	Nominal Tank Diameter m (ft)
> 16 ($\frac{5}{8}$)	All
From 13 ($\frac{1}{2}$) to < 16 ($\frac{5}{8}$)	< 36 (120)
From 10 ($\frac{3}{8}$) to < 13 ($\frac{1}{2}$)	< 18 (60)
From 5 ($\frac{3}{16}$) to < 10 ($\frac{3}{8}$)	< 12 (40)
For Aluminum Plates	
Nominal Plate Thickness mm (in.)	Nominal Tank Diameter m (ft)
> 16 ($\frac{5}{8}$)	All
From 13 ($\frac{1}{2}$) to < 16 ($\frac{5}{8}$)	< 27 (90)
From 10 ($\frac{3}{8}$) to < 13 ($\frac{1}{2}$)	< 15 (50)
From 5 ($\frac{3}{16}$) to < 10 ($\frac{3}{8}$)	< 9 (30)

are left to the judgement of the manufacturer in order to produce an acceptable tank. Outer walls of double-wall tanks (see Appendixes Q and R) that contain insulation and are not in contact with the design liquid are excluded. These tolerances may be waived or modified by agreement between the purchaser and the manufacturer.

6.5.2 Plumbness

6.5.2.1 For cylindrical sidewalls, the maximum out-of-plumbness of the top of the shell relative to the bottom of the shell shall not exceed $\frac{1}{200}$ of the total tank height.

6.5.2.2 The out-of-plumbness in one shell plate shall not exceed the permissible variations for flatness and waviness specified in ASTM A 6 or ASTM A 20, whichever is applicable for carbon and alloy steels. For stainless steels, ASTM A 480 is applicable. For aluminum plates, Table 5.13 of ANSI H35.2 provides the dimensional flatness tolerance.

6.5.3 Roundness

6.5.3.1 For cylindrical sidewalls, the horizontal circular cross section of a large, low pressure storage tank shall be sufficiently true to round so that the difference between the maximum and minimum diameters (measured inside or outside) at any section in a cylindrical wall shall not exceed 1% of the average diameter or 12 in., whichever is less, except as modified for flat-bottom tanks for which the radii measured at 1 ft 0 in. above the bottom corner weld shall not exceed the tolerances listed in Table 6-1.

6.5.3.2 The skirts or cylindrical ends of formed tops or bottoms shall be sufficiently true to round so that the difference between the maximum and minimum diameters shall not exceed 1% of the nominal diameter.

6.5.4 Local Deviations

Local deviations from the theoretical shape, such as weld discontinuities and flat spots, shall be limited as follows:

a. Using a horizontal sweep board 36-in. long, peaking at vertical joints shall not exceed $\frac{1}{2}$ in. This may be increased to 1 in. for aluminum shells (see Appendix Q).

04 | Table 6-2—Diameter Range Versus Radius Tolerance

Diameter Range (ft)	Radius Tolerance (in.)
< 40	$\pm \frac{1}{2}$
40 to < 150	$\pm \frac{3}{4}$
150 to < 250	± 1
≥ 250	$\pm 1\frac{1}{4}$

b. Using a vertical sweep board 36-in. long, banding at horizontal joints shall not exceed $\frac{1}{2}$ in. This may be increased to 1 in. for aluminum shells (see Appendix Q).

c. Flat spots in the vertical plane shall not exceed the appropriate plate flatness and waviness requirements of 6.5.2.2.

6.5.5 Fitting Attachments

All lugs, brackets, nozzles, manhole frames, reinforcement around openings, and other appurtenances shall fit and conform to the curvature of the surface to which they are attached.

6.5.6 Foundation

6.5.6.1 To achieve the tolerances outlined in 6.5, a level foundation must be provided for the tank erection. The foundation should have adequate bearing power to maintain the levelness of the foundation.

6.5.6.2 The top of the foundation with a concrete ringwall shall be level within $\pm \frac{1}{8}$ in. in any 30 ft of circumference and within $\pm \frac{1}{4}$ in. in the total circumference. Without a concrete ringwall, the foundation shall be within $\pm \frac{1}{2}$ in. of the design shape.

6.5.6.3 For concrete slab foundations, from the outside of the tank radially toward the center, the first foot of the foundation (or width of the annular ring) shall comply with the concrete ringwall requirement. The remainder of the foundation shall be within $\pm \frac{1}{2}$ in. of the design shape.

6.5.7 Measurements

When measurements are required by agreement between the purchaser and the manufacturer, they shall be taken before the hydrostatic test. Measurements of local deviations shall be taken during construction. They shall be taken with a steel tape—making corrections for temperature, sag, and wind—when the length being measured makes such corrections nec-

essary. Deviation measurements shall be taken on the surface of the plate and not on welds.

6.5.8 Double-Curvature Roofs, Bottoms, and Sidewalls

For double-curvature roofs, bottoms and sidewalls, the tolerances shall be as follows: The surface shall not deviate outside the design shape by more than 1.25% of D and inside the specified shape by more than $\frac{5}{8}\%$ of D where D is the nominal inside diameter of the roof (or bottom) under consideration. Such deviations shall be measured perpendicular to the design shape and shall not be abrupt but shall merge smoothly into the adjoining surfaces in all directions. For a knuckle, D shall be considered to be twice the radius of the knuckle.

6.6 DETAILS OF WELDING

6.6.1 General

6.6.1.1 Tanks and tank parts fabricated under these rules shall be welded by the processes defined in 6.6.2. Welding may be performed by manual, semi-automatic arc, or machine welding according to procedures described in ASME Section IX, and by welders and welder operators qualified under 6.7 and 6.8.

6.6.1.2 Welding shall be fusion welding without the application of mechanical pressure or blows.

6.6.1.3 Peening is permitted in accordance with 6.19.

6.6.1.4 Pipe materials that have longitudinal joints of the types permitted by the specifications listed in 4.3 are allowed.

6.6.2 Welding Processes

Tanks and their structural attachments shall be welded by the shielded metal-arc, gas metal-arc, gas tungsten-arc, oxy-fuel, flux-cored-arc, submerged-arc, electroslag, or electrogas process using suitable equipment. Use of the oxyfuel, electroslag, or electrogas process shall be by agreement between the manufacturer and the purchaser. Use of the oxyfuel process is not permitted when impact testing of the material is required. Welding may be performed by manual, semi-automatic arc, or machine welding according to procedures described in ASME Section IX. Welding shall be performed in such a manner as to ensure complete fusion with the base metal.

6.7 QUALIFICATION OF WELDING PROCEDURE

6.7.1 Each Welding Procedure Specification (WPS) shall be qualified in accordance with the latest practice as given in Section IX of the ASME Code. When impact tests are required by 4.2.5 or when required by appropriate appendixes, the weld metal and heat affected zone shall be tested and the Supplementary Essential Variables in Section IX of the ASME Code shall be applied. In addition, the heat treated

condition and the application or omission of fine grain practice for the base metal shall be an additional Supplementary Essential Variable.

6.7.2 Carbon steel materials not listed in Table QW-422 of Section IX of the ASME Code shall be considered as P-Number 1 material with group numbers assigned as follows, according to the minimum tensile strength specified:

- a. < 70 kips/in.² (Group 1).
- b. ≥ 70 kips/in.² but ≤ 80 kips/in.² (Group 2).
- c. > 80 kips/in.² (Group 3).

6.7.3 The required tests to qualify the Welding Procedure Specification (WPS) shall be conducted by the fabricator.

6.7.4 The stress-relieving requirements in the procedures to be followed in each case should be agreed upon between the manufacturer and the purchaser. Peening may be done if it is part of the welding procedure and is approved by the purchaser.

6.8 QUALIFICATION OF WELDERS

6.8.1 All welders assigned to manual or semi-automatic arc welding, and welding operators assigned to machine welding, shall have successfully passed the tests conducted by the fabricator, or manufacturer, as prescribed for welder qualification in Section IX of the ASME Code. Tests conducted by one manufacturer shall not qualify a welder or welding operator to do work for any other manufacturer.

6.8.2 The manufacturer shall assign each welder or welding operator an identifying number, letter, or symbol. Except for all lap-welded roof seams and flange-to-neck joints, this identifying mark shall be stamped, either by hand or machine, on all tanks adjacent to and at intervals of not more than 3 ft along the welds made by a welder or welding operator; alternatively, the manufacturer may keep a record of welders employed on each joint and shell-opening joint and omit the stamping. If such a record is kept, it shall be maintained until tests are completed and shall be available to the inspector.

6.8.3 The manufacturer shall maintain a record of the welders employed, showing the date and result of tests and the identification mark assigned to each. These records shall be certified by the manufacturer and shall be accessible to the inspector.

6.9 MATCHING PLATES

6.9.1 The plates that are being welded shall be accurately matched and retained in position during the welding operation. Tack welds may be used to hold the plate edges in line if the requirements of 6.9.1.1 through 6.9.1.4 are followed.

6.9.1.1 The tack welds in butt joints to be welded manually are removed before welding.

6.9.1.2 The tack welds in butt joints to be machine welded by a process that will re-melt the tack welds shall be thoroughly cleaned of all welding slag and examined for soundness.

6.9.1.3 Tack welds in lap and fillet welded joints need not be removed if they are sound and the subsequently applied weld beads are thoroughly fused into the tack welds.

6.9.1.4 Tack welds, whether removed or left in place, shall be made using a fillet-weld or butt-weld procedure qualified in accordance with Section IX of the ASME Code. Tack welds to be left in place shall be made by welders qualified in accordance with Section IX of the ASME Code and shall be examined visually for defects; if welds are found to be defective, they shall be removed.

6.9.2 During assembly of the plates and subject to agreement between the manufacturer and the purchaser, the welded joints in adjoining segments, which abut at a common transverse joint from opposite sides, need not be staggered unless specified by the purchaser. When specified, the stagger should be at least five times the plate thickness of the thicker course.

6.10 CLEANING SURFACES TO BE WELDED

6.10.1 Immediately before any welding operation, the surface to be welded or to which weld metal is to be applied shall be cleaned thoroughly of all scale, slag, grease, and any oxide that would lower the quality of the deposited weld metal. A light oxide film resulting from flame cutting is not considered detrimental.

6.10.2 On all multilayer welding, each layer of weld metal shall be cleaned of slag and other deposits before the next layer is applied.

6.10.3 The reverse side of double welded butt joints shall be prepared by chipping, grinding, or melting out to ensure sound metal at the base of the weld metal first deposited before weld metal is applied from the reverse side. This operation shall be done to ensure complete penetration and proper fusion in the final weld. When melting out is done, particular care shall be exercised to prevent contamination of the melted area by foreign materials, especially carbon.

Note: The proceeding requirements of this section are not intended to apply to any welding procedure by which proper fusion and complete penetration are otherwise obtained and by which unacceptable defects at the base of the weld are avoided.

6.10.4 Cast steel surfaces to be welded must first be machines or chipped to remove foundry scale and to expose sound metal.

6.11 WEATHER CONDITIONS FOR WELDING

Welding shall not be done (a) when the surfaces of the parts to be welded are wet from rain, snow, or ice, (b) when rain or snow is falling, or (c) when periods of high winds prevail, unless the welder and work are properly shielded. Welding shall not be done when the base metal temperature is less than 0°F. When the base metal temperature is within the range of 0°F – 32°F, inclusive, or the thickness is in excess of 1¹/₄ in., the base metal within 3 in. of the place where welding is to be started shall be heated to a temperature that is warm to the hand.

6.12 REINFORCEMENT ON WELDS

6.12.1 Butt joints shall have complete joint penetration and complete fusion for the full length of the weld and shall be free from undercuts, overlaps, or abrupt ridges or valleys. To ensure that the weld grooves are completely filled so that the surface of the weld metal at any point does not fall below the surface of the adjoining plate, weld metal may be built up as reinforcement on each side of the plate. The thickness of the reinforcement on each side of the plate shall not exceed the thickness listed in Table 6-2, but the reinforcement need not be removed except when it exceeds the permissible thickness or when required in 7.15.1.

6.12.2 When a single-welded butt joint is made by using a backing strip that is left in place (see Table 5-2), the requirement for reinforcement applies to only the side opposite the backing strip.

6.13 MERGING WELD WITH PLATE SURFACE

The edges of the weld shall merge smoothly with the surface of the plate without a sharp angle. There shall be a maximum permissible undercutting of 1/64 in. for longitudinal or meridional butt joints and 1/32 in. for circumferential or latitudinal butt joints.

6.14 ALIGNING OF MAIN JOINTS

Particular care shall be taken in matching up the edges of all plates within the tolerances of offset as follows:

- a. For plates 1/4 in. in thickness and less, 1/16 in.
- b. For plates over 1/4 in. in thickness, 25% of the plate thickness or 1/8 in., whichever is smaller.

6.15 REPAIRING DEFECTS IN WELDS

Defects in welds shall be chipped, melted out, or machined out until sound metal is reached on all sides. Subject to the approval of the inspector, the resulting cavity shall be filled with the weld metal and retested

6.16 MATCHING PLATES OF UNEQUAL THICKNESS

For plates over 1/2-in. thick in the sidewalls, roof, or bottom of a tank, if the thickness of two adjacent plates that are to be butt-welded together differ by more than 1/8 in., the thicker plate shall be trimmed to a smooth taper that extends for a distance at least four times the offset between the abutting surfaces so that the adjoining edges will be of approximately the same thickness. The length of the required taper may include the width of the weld (see Figure 6-1).

Table 6-3—Maximum Thickness of Reinforcement on Welds

Plate Thickness (in.)	Maximum Reinforcement (in.)	
	Vertical Joints	Horizontal Joints
≤ 1/2	3/32	1/8
> 1/2 thru 1	1/8	3/16
> 1	3/16	1/4

6.17 FITTING UP OF CLOSURE PLATES

For the closure of the final joints, plates of extra width and length—not narrow strips or filler bars³³—shall be used. The fitting up of the closure plates used and the proposed method of installation shall be subject to the inspector's approval before the work is started, and the inspector shall ensure that the closure plates meet all applicable requirements.

6.18 THERMAL STRESS RELIEF

6.18.1 General thermal stress relief of an entire tank is not visualized for tanks of this type, but sections of tanks shall be stress relieved before erection where required by the provisions of 5.25.

6.18.2 Parts of a tank that require stress relief according to the rules in 5.25 shall be stress relieved in an enclosed furnace before shipment from the fabricators' shops. The procedure used shall be as outlined in 6.18.2.1 through 6.18.2.5.

6.18.2.1 The temperature of the furnace shall not exceed 600°F at the time the part or section of the tank is placed in it.

6.18.2.2 The rate of heating in excess of 600°F shall be not more than 400°F per hour divided by the maximum metal thickness, in in., of the wall plate being heated, but in no case shall it be more than 400°F per hour.

³³Gaps of this kind may require removal of part of the adjoining plate to give proper widths. Full consideration should be given to radiographic and magnetic-particle methods of inspection as well as to the thermal stress relief or peening of these welds.

6.18.2.3 During the heating period, the temperature throughout the portion of the tank being heated shall not vary more than 250°F within any 15-ft interval of length and when at the hold temperature not more than 150°F throughout the portion of the tank being heated. A minimum temperature of 1100°F (except as permitted in 6.18.2.5) shall be maintained for a period of one hour per in. of metal thickness (maximum metal thickness of the tank wall plates affected). During the heating and holding periods, the furnace atmosphere shall be controlled to avoid excessive oxidation of the surface of the material being treated. The furnace shall be designed to prevent direct impingement of the flame on the material.

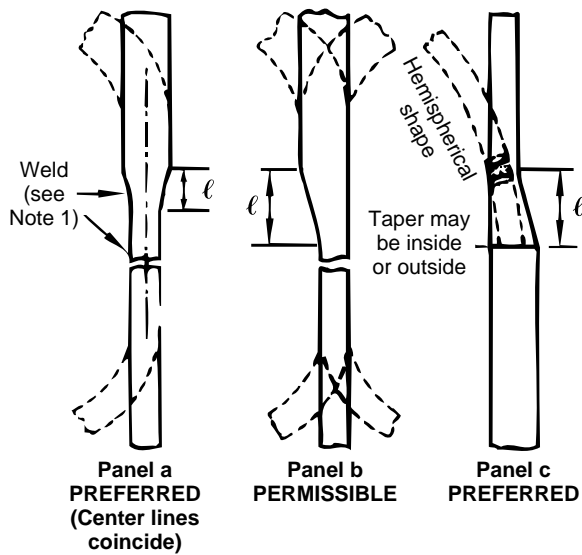

Notes:

1. The length of the required taper ℓ may include the width of the weld.
2. In all cases, ℓ shall be not less than four times the offset between the abutting plates.

Figure 6-1—Butt Welding of Plates of Unequal Thickness

Table 6-4—Stress-Relieving Temperatures and Holding Times

Metal Temperature (° Fahrenheit)	Holding Time (hours per in. of thickness)
1100	1
1050	2
1000	3
950	5
900 (minimum)	10

Note: For intermediate temperatures, the heating time shall be determined by straight line interpolation.

6.18.2.4 At temperatures over 600°F, cooling shall be done in a closed furnace or cooling chamber at a rate not greater than 500°F per hour divided by the maximum metal thickness, in in. of the plates affected; in no case shall the rate be more than 500°F per hour. At temperatures of 600°F and below, the material may be cooled in still air.

6.18.2.5 When stress relieving at a temperature of 1100°F is impracticable, it is permissible to carry out the stress relieving operation at lower temperatures for longer time periods in accordance with Table 6-3.

6.19 PEENING FIELD WELDS

6.19.1 A tank fabricated according to these rules that is too large to be completely assembled and welded in a shop may be transported in sections and assembled in the field. Welds made after assembly in the field may require a special welding procedure in accordance with 5.25, and mechanical peening as described in Appendix I may then be used on the field welds.

6.19.2 Peening of welds is not considered as effective as thermal stress relief and is not to be substituted for thermal stress relief where the thermal stress relief is mandatory under the provision of 5.25.

**For Committee
Use Only**

SECTION 7—INSPECTION, EXAMINATION AND TESTING

7.1 RESPONSIBILITY OF EXAMINER

7.1.1 The inspector³⁴ shall ensure that all materials used in tanks constructed according to the rules in this standard comply in all respects with the requirements of these rules. This shall be done either by witnessing mill tests or examining certified mill test reports supplied by the manufacturer.

7.1.2 Tanks constructed according to the rules in this standard shall be inspected and tested in accordance with the sections that follow. The inspector shall carefully follow the fabrication and testing of each tank and shall make sure that they comply in all details with the design, fabrication, and tests specified in these rules.

7.2 QUALIFICATIONS OF EXAMINERS

7.2.1 Examiners for tanks constructed according to the rules in this standard shall have had not less than 5 years experience in design, construction, maintenance and/or repair, or in the responsible supervision of the construction, maintenance and/or repair of various types of unfired pressure vessels and/or tanks, including at least 1 year of experience in the construction or supervision of the construction of vessels or tanks by fusion welding. Satisfactory completion of a suitable course of training approved by the purchaser or the purchaser's agent may be substituted for 3 of the 5 years experience. However, training cannot replace more than 6 months of the required experience on fusion-welding construction.

7.2.2 Inspectors shall be employed by the purchaser or by an organization regularly engaged in making inspections. An examiner is the accredited representative of the purchaser.

7.2.3 The manufacturer shall also provide inspection to help ensure that all requirements of these rules have been met before signing the certificate and manufacturer's report (see 8.3).

7.3 ACCESS FOR INSPECTOR

The inspector shall be permitted free access to all parts of the plant concerned with the manufacture of the tank during fabrication and to all parts of the plants of material suppliers who are concerned with the manufacture of materials to be used in the tank.

7.4 FACILITIES FOR INSPECTOR

The manufacturer shall afford the inspector all reasonable facilities for testing and inspection and shall provide mutually agreeable advance notification to permit the examiner to wit-

ness all tests of the equipment and materials during fabrication, including all laboratory tests of the material to be used and all hydrostatic and pneumatic tests at the site of erection.

7.5 APPROVAL OF REPAIRS

Approval by the inspector shall be required before and after any defects are repaired. Defective material that cannot be satisfactorily repaired shall be rejected (see 6.16 for repair of defects in welds).

7.6 INSPECTION OF MATERIALS

The plates and other material for parts that will be subjected to pressure-imposed loads shall be inspected before being incorporated in the tank. Particular attention shall be given to all cut edges to ensure that the material is free from serious laminations and other defects.

7.7 STAMPING OF PLATES

Before plates required to be stamped by the steel mill are used, the inspector shall see that they bear the stamp. In laying out and cutting the plates, at least one set of the original material identification markings should, if possible, be left where it will be plainly visible when the tank is completed. Should the identifying marks be obliterated, one set shall be accurately transferred by the tank manufacturer to a location that will be visible on the completed tank, or a coded marking shall be used to ensure identification of each piece of material during fabrication and subsequent identification of the markings on the completed tank. These latter markings shall be readily distinguishable from the mill markings. The inspector need not witness the transfer of the markings but shall be satisfied that the transfer of the markings has been made correctly. Care should be taken not to damage the plate by stamping the figures too deeply. To guard against incipient cracks in plates less than $\frac{1}{4}$ in. thick, the mill markings shall be transferred in some manner other than by die stamping.

7.8 MEASURING THICKNESS OF MATERIAL

All material shall be gauged or measured to determine whether the thickness meets the requirements.

7.9 INSPECTION OF SURFACES EXPOSED DURING FABRICATION

7.9.1 The edges of plates, openings and fittings exposed during fabrication shall be inspected carefully to make sure that any defects have been uncovered, as well as to determine that the work has been performed properly.

7.9.2 Minor defects found may be repaired only after the inspector approves the method and extent of repairs. Materials that have more than minor defects that cannot be satisfactorily repaired shall be rejected.

³⁴The term inspector, as used here and elsewhere in this standard, refers to an individual who has the qualifications set forth in 7.2.

7.10 SURFACE INSPECTION OF COMPONENT PARTS

Before assembly, unless already so certified by shop inspectors, all sidewall plates or sections and roof and bottom plates shall be inspected for thickness, freedom from injurious defects, and soundness of any welded joints.

7.11 CHECK OF DIMENSIONS OF COMPONENT PARTS

All formed plates and curved sections shall be checked for conformance with the planned dimensions and cross section. For unusual repairs the inspector should keep a record of measurements taken at sufficient intervals to constitute a satisfactory record.

7.12 CHECK OF CHEMICAL AND PHYSICAL PROPERTY DATA

The inspector shall check the material being assembled by the lists of the plates from the mill, their heat numbers, chemical analyses, and mechanical properties as given on mill reports and shall see that copies are available to be attached to the manufacturer's report (see 8.3).

7.13 DATA REQUIRED FROM MANUFACTURER ON COMPLETED TANKS

If specified in the purchase order, the manufacturer shall supply marked copies of plans (or a separate sketch) showing the location of all plates, with a means of identifying each plate with the heat numbers. These markings shall be checked by the inspector. A copy shall be attached to the manufacturer's report.

7.14 CHECK OF STRESS-RELIEVING OPERATION

The inspector shall check any thermal stress-relieving operation and shall be satisfied that the temperature readings are accurate and that the procedure conforms to the applicable requirements of these rules.

7.15 EXAMINATION METHOD AND ACCEPTANCE CRITERIA

7.15.1 Radiographic Method

7.15.1.1 Except as modified in this section, the radiographic examination method employed shall be in accordance with Section V, Article 2 of the ASME Code. The requirements of T-285 in Section V, Article 2, are to be used only as a guide. Final acceptance of radiographs shall be based on the ability to see the prescribed image quality indicator (IQI) (penetrameter) and the specified hole or wire. The finished surface of the reinforcement at the location of the radiograph shall either be flush with the plate or have a reasonably uniform crown that does not exceed the values listed in Table 7-1.

Table 7-1—Maximum Thickness of Reinforcement on Welds for Radiography Examined Joints

Plate Thickness (in.)	Maximum Thickness of Reinforcement (in.)
$\leq 1/2$	1/16
$> 1/2 - 1$	3/32
> 1	1/8

7.15.1.2 Before any welds are repaired, the radiographs shall be submitted to the inspector.

7.15.1.3 The acceptability of welds examined by radiography shall be judged by the standards of Paragraph UW-51(b) in Section VIII of the ASME Code.

7.15.1.4 Sections of welds that radiography has revealed to be unacceptable shall be repaired and re-radiographed in accordance with 7.15.1.1 and their acceptability shall be determined by the standards of 7.15.1.3.

7.15.1.5 After the structure is completed, the films shall be the property of the purchaser unless otherwise agreed upon by the purchaser and the manufacturer.

7.15.1.6 Personnel who perform and evaluate radiographic examination according to this section shall be qualified and certified by the manufacturer as meeting requirements of certification as generally outlined in ASNT SNT-TC-1A (including applicable supplements), Level II or Level III. Level I personnel may be used if they are given written acceptance/rejection procedures prepared by Level II or III personnel. This written procedure shall contain the applicable requirements of Section V, Article 2, of the ASME Code. In addition, all Level I personnel shall be under the direct supervision of Level II or III personnel.

7.15.2 Magnetic-Particle Method Examination

7.15.2.1 When magnetic-particle examination is specified, the method of examination shall be in accordance with Section V, Article 7 of the ASME Code.

7.15.2.2 Magnetic-particle examination shall be performed in accordance with a written procedure, which shall be in accordance with the requirements of T-150, Section V, Article I of the ASME Code.

7.15.2.3 The manufacturer shall determine that each magnetic-particle examiner meets the following requirements:

a. The examiner has vision with correction, if necessary, to be able to read a Jaeger-Type No. 2 Standard Chart at a distance of not less than 12 in. and is capable of distinguishing

and differentiating contrast between colors used. These requirements shall be checked annually.

b. The examiner is competent in the techniques of the magnetic-particle examination method for which the examiner is certified, including making the examinations and interpreting and evaluating the results; however, where the examination method consists of more than one operation, the examiner may be certified as being qualified only for one or more of these operations.

7.15.2.4 The acceptance standards, defect removal, and repair shall be in accordance with Section VIII, Appendix 6, Paragraphs 6-3, 6-4, and 6-5 of the ASME Code.

7.15.3 Ultrasonic Examination Method

7.15.3.1 Ultrasonic Examination in Lieu of Radiography

When ultrasonic examination is applied in order to fulfill the requirements of 5.26, Q.7.6, or R.7.6, the provisions of Appendix U shall apply.

7.15.3.2 Ultrasonic Examination NOT in Lieu of Radiography

7.15.3.2.1 When the radiographic method is applied in order to fulfill the requirements of 5.26, any ultrasonic examination specified shall be in accordance with this section.

7.15.3.2.2 The method of examination shall be in accordance with Section V, Article 4, of the ASME Code. Acceptance standards shall be by agreement between purchaser and manufacturer.

7.15.3.2.3 Ultrasonic examination shall be performed in accordance with a written procedure that is certified by the manufacturer to be in compliance with the applicable requirements of Section V of the ASME Code.

7.15.3.2.4 Examiners who perform ultrasonic examination under this section shall be qualified and certified by the manufacturer as meeting the requirements of certification as generally outlined in ASNT SNT-TC-1A (including applicable supplements), Level II or Level III. Level I personnel may be used if they are given written acceptance/rejection criteria prepared by Level II or III personnel. In addition, all Level I personnel shall be under the direct supervision of Level II or III personnel.

7.15.4 Liquid-Penetrant Examination Method

7.15.4.1 When liquid-penetrant examination is specified, the method of examination shall be in accordance with Section V, Article 6, of the ASME Code.

7.15.4.2 Liquid-penetrant examination shall be performed in accordance with a written procedure certified by the manufacturer to be in compliance with applicable requirements of Section V of the ASME Code.

7.15.4.3 The manufacturer shall determine and certify that each liquid-penetrant examiner meets the following requirements:

a. The examiner has vision with correction, if necessary, to be able to read a Jaeger-Type No. 2 Standard Chart at a distance of not less than 12 in. and is capable of distinguishing and differentiating contrast between colors used. These requirements shall be checked annually.

b. The examiner is competent in the techniques of the liquid penetrant examination method for which the examiner is certified, including making the examination and interpreting and evaluating the results; however, where the examination method consists of more than one operation, the examiner may be certified as being qualified only for one or more of these operations.

7.15.4.4 The acceptance standards, defect removal, and repair shall be in accordance with Section VIII, Appendix 8, Paragraphs 8-3, 8-4, and 8-5 of the ASME Code.

7.15.5 Visual Examination Method

7.15.5.1 All welds shall be visually examined in accordance with 7.15.5.2 and 7.15.5.3.

7.15.5.2 A weld shall be acceptable by visual examination if examination shows the following:

- The weld has no crater cracks or other surface cracks.
- Undercut does not exceed the applicable limit in 6.13 for circumferential or latitudinal butt joints and for longitudinal or meridional butt joints. For welds that attach nozzles, man-holes, or clean-out openings, the maximum allowable undercut is $1/64$ in.
- The frequency of surface porosity in welds does not exceed one cluster (one or more pores) in each 4 in. of length, and the maximum diameter of each cluster does not exceed $3/32$ in.
- Complete fusion and required penetration exists at the joint between the weld metal and the base metal.

7.15.5.3 Welds that fail to meet the visual examination criteria of 7.15.5.2 shall be reworked before hydrostatic testing in accordance with the following:

- Defects shall be repaired in accordance with 6.16.
- Rewelding shall be required if the resulting thickness is below the minimum required for design and hydrostatic test conditions. All defects in areas above the minimum thickness shall be feathered to at least 4:1 taper.
- The repair weld shall be examined visually for defects.

7.15.6 Examination Method for Spot Radiographic/Ultrasonic Examination

7.15.6.1 The procedure prescribed in 7.15.1.1 shall be followed as closely as is practicable when the spot examination is made by radiography. A spot radiograph shall not be considered equivalent to a recheck where complete radiography is mandatory and applied.

7.15.6.2 Spot radiographic or ultrasonic examination shall be not less than 6 in. extending along the weld. Spot radiography shall comply with the standards given in 7.15.1.3. Where spot radiographic or ultrasonic examination is applied at joint intersections, the surface shall be prepared and examined for a distance of 3 in. on each side of the intersection, making the minimum length of examination 6 in. on the horizontal weld and 3 in. on the vertical weld.

7.15.6.3 Retest radiographs prescribed in 7.17.4, when required, shall comply with the standards of acceptability given in 7.15.1.3. Spot radiographs or ultrasonic records may be discarded after the tank has been accepted by the inspector, unless previously requested by the purchaser.

7.16 INSPECTION OF WELDS

Note: Appendix P summarizes the requirements by method of examination and provides the acceptance standards, examiner qualifications, and procedure requirements. Appendix P is not intended to be used alone to determine the inspection requirements for work covered by this document. The specific requirements as listed in Sections 1 through 9, and Appendices Q and R shall be followed in all cases.

7.16.1 Butt-Welds

Complete penetration and complete fusion is required (to the degree mandated by the acceptance criteria for examination method utilized) for welds joining tank wall plates to tank wall plates. Examination for quality of welds shall be made using either the radiographic method specified in 7.15.1 and applied in 7.17, or alternatively, by agreement between the purchaser and the manufacturer, using the ultrasonic method specified in 7.15.3.1. In addition to the radiographic or ultrasonic examination, these welds shall also be visually examined as specified in 7.15.5. Furthermore, the purchaser's inspector may visually inspect all butt-welds for cracks, arc strikes, excessive undercuts, surface porosity, incomplete fusion, and other defects. Acceptance and repair criteria for the visual method are specified in 7.15.5.

7.16.2 Fillet Welds

Fillet welds shall be examined by the visual method. Acceptance and repair criteria are specified in 7.15.5.

7.16.3 Permanent and Temporary Attachment Welds

7.16.3.1 Permanent attachments are items welded to the tank wall that will remain while the tank is in its intended service. This does not include openings such as nozzles, manholes and flush type cleanouts. It does include items such as wind girders, stairs, gauging systems, davits, riser pipe supports, tank anchors, walkways, supports for internal items such as heating coils or other piping, ladders, floating roof supports welded to the shell wall, and electrical conduit and fixtures. Items installed above the maximum liquid level of the tank are not permanent attachments. The weld connecting the permanent attachment to the tank surface shall be inspected visually and by the magnetic particle method (or at the option of the purchaser, by the liquid penetrant method). Refer to Section 7 for the appropriate inspection criteria.

7.16.3.2 Temporary attachments are items welded to the tank wall that will be removed prior to the tank being utilized in its intended service. These are usually construction items such as alignment clips, scaffolding clips, stabilizers, fitting equipment, and lifting clips. The area from which a temporary attachment is removed shall be inspected visually for any indication of flaws requiring repair. Additionally, on any tank material listed in Table 4-1 at -15°C (5°F) and greater than 12 mm ($1/2$ in.) thick, and on all materials listed in Table 2-1 at -37°C (-35°F), shall be examined by the magnetic particle method (or at the option of the purchaser, by the liquid penetrant method). Refer to Section 7 for the appropriate inspection criteria.

7.16.4 Examination of Welds Following Stress Relieving

After any stress relieving, but before hydrostatic testing of the tank, welds attaching nozzles, manholes, and cleanout openings shall be examined visually and by the magnetic particle method (or at the option of the purchaser, the liquid penetrant method). Refer to 7.15.2, 7.15.4, or 7.15.5 for the appropriate examination and repair criteria.

7.16.5 Responsibility

The manufacturer shall be responsible for examinations and any necessary repairs; however, if the purchaser's inspector requires examinations in excess of the number specified in 7.17 or requires chip-outs of fillet welds in excess of one per 100 ft of weld and no defect is disclosed, the additional examination and related work shall be the responsibility of the purchaser.

04 | 7.17 RADIOGRAPHIC/ULTRASONIC EXAMINATION REQUIREMENTS

7.17.1 Application

04 | **7.17.1.1** Any butt-welded joint in the wall of any tank to which these rules apply, and for which complete examination is mandatory under 5.26, shall be examined throughout its entire length by the radiographic or ultrasonic method as prescribed by the following sections. Any butt-welded joint for which complete examination would not be mandatory under 5.26.3 shall be similarly examined if the procedure becomes mandatory in the application of 5.26.4.

04 | **7.17.1.2** If radiographic or ultrasonic examination is considered impractical for the final (or closing-up) joint because of the location or construction of that joint, magnetic-particle examination may be substituted for radiographic or ultrasonic examination of the joint if the substitute procedure is applied at stages of the welding acceptable to the inspector and it indicates that the joint is sound. In no case shall this exception be interpreted to apply because equipment suitable for making the radiographic or ultrasonic examination is not available, or is not in a usable condition.

7.17.1.3 All such welded joints on which backing strips are to remain shall be examined by the magnetic-particle method after the first two layers, or beads, of weld metal have been deposited and again after the joint has been completed.

7.17.2 Spot Examination of Welded Joints

04 | **7.17.2.1** For all butt-welded main joints (see 5.26.5.2) that are not completely examined, spot examination is mandatory and shall be done according to the procedure and standards of 7.15.6 and 7.17.4, except roof joints exempted by Table 5-2.

7.17.2.2 Spot examination need not be made of welds in structural steel members unless specifically requested by the inspector. The method used shall be subject to agreement between the manufacturer and the inspector.

7.17.3 Number and Location of Spot Examination

7.17.3.1 In all cases in which spot examination is mandatory under 7.17.2.1, the number and location of spots examined in longitudinal or meridional joints and in equivalent circumferential or latitudinal joints as defined in Table 5-2,

04 | Note 5, shall conform to the requirements of 7.17.3.2 through 7.17.3.4.

7.17.3.2 At least one spot shall be examined from the first 10 ft of completed joint of each type and thickness³⁵ welded by each welder or welding operator. Thereafter, without regard to the number of welders or welding operators

³⁵This is based on the thickness of the thinner plate at the joint. For the purpose of this application, plates shall be considered of the same thickness when the difference in the specified or design thickness does not exceed $1/8$ in.

involved, one additional spot shall be examined for each additional 50 ft—or remaining fractional part of this length—of each type and thickness of welded longitudinal, meridional, or equivalent joint subject to examination. The inspector shall designate the locations of all spots that are to be examined, of which at least 25% of the selected spots shall be at junctions of meridional and latitudinal joints with a minimum of two such intersections per tank (see 7.15.6.2), both under the foregoing provisions and the provisions of 7.17.3.4. Such spots need not have any regularity of spacing.

7.17.3.3 If more than one welding procedure is used or if more than one welder or welding operator does the welding, at least one spot shall be examined for each procedure and for each welder or welding operator. Any spot examined may coincidentally represent one procedure, one welder or welding operator, and one interval of 50 ft of joint length. The same welder or welding operator may or may not weld both sides of the same butt joints; therefore, it is permissible to test the work of two welders or welding operators with one spot examination if they weld opposite sides of the same butt joint. When a spot of this type is rejected, further tests shall determine whether one or both welders or welding operators were at fault.

7.17.3.4 Whenever spot examination is required for circumferential or latitudinal joints other than those considered in 7.17.3.2 and 7.17.3.3, one spot shall be examined from the first 10 ft of completed joint of each type and thickness (see Footnote 35) welded by each welder or welding operator if not already done on other joints for the same welder or welding operator on the same structure. Thereafter, without regard to the number of welders or welding operators working, one additional spot shall be examined in each additional 100 ft (approximately) and any remaining fraction thereof of each type and thickness of welded circumferential or latitudinal joints of the kind considered in 7.17.2.

7.17.4 Spot-Examination Retests

7.17.4.1 When a spot has been examined at any location selected in accordance with 7.17.2 and the welding does not comply with the standards prescribed in 7.15.1.3 for radiographic examination, or Appendix U for ultrasonic examination, two additional spots shall be examined in the same seam at locations to be selected by the inspector—one on each side of the original spot—to determine the limits of the potentially deficient welding. If any welding is found at either spot that fails to comply with the minimum quality requirements in 7.15.1.3 radiographic examination, or Appendix U for ultrasonic examination, additional spots nearby shall be examined until the limits of unacceptable welding are determined. In addition, the inspector may require that an additional spot be examined at one location selected by the inspector in each

seam not previously examined on which the same operator has welded. If any additional spot fails to comply with the minimum quality requirements, the limits of unacceptable welding shall be determined as in the original examination.

04 | **7.17.4.2** All welding within the limit for spot examination found to be below the standards required in 7.15.1.3 for radiographic examination, or Appendix U for ultrasonic examination, shall be rejected. The rejected weld shall be removed and the joint shall be rewelded, or at the manufacturer's option, the entire unit of weld represented shall be completely examined and only the defective welding need be corrected.

7.18 STANDARD HYDROSTATIC AND PNEUMATIC TESTS

7.18.1 General

After erection is completed and stress relieving, radiographic examinations, or other similar operations, as may be required, are performed, each tank shall satisfactorily pass a series of hydrostatic and pneumatic tests as prescribed in 7.18.2 through 7.18.6. Whenever a solution film is specified in this section to be applied to welding, linseed oil or another equivalent material for disclosing air leakage may be substituted. In freezing weather, linseed oil or a similarly suitable material shall be used.

7.18.2 Test Preliminaries

7.18.2.1 Before water is introduced into the tank, the preliminary operations described in 7.18.2.2 through 7.18.2.6 shall be performed.

7.18.2.2 The attachment welding around all openings and their reinforcements in the walls of the tank shall be examined by the magnetic-particle method both inside and outside the tank. When the underside of a tank bottom rests directly on the tank grade (and is not accessible after erection), such examination of welding on the underside of the bottom and subsequent air testing may be omitted. However, such examination and testing of any openings in the bottom plates shall be done before these plates are placed in position on the tank grade.

7.18.2.3 Following the examination specified in 7.18.2.2, air at a pressure of 15 lbf/in.² gauge (or, if the parts involved cannot safely withstand this pressure, as near this pressure as the parts should safely withstand) shall be introduced between the tank wall and the reinforcing plate, saddle flange, or integral reinforcing pad on each opening, using the telltale holes specified in 5.16.10. While each space is subject to the pressure, a solution film shall be applied to all attachment welding around the reinforcement, both inside and outside the tank.

7.18.2.4 In cases in which the bottom of the tank rests directly on the tank grade (preventing access to the underside

of the bottom of the tank), all joints between the bottom plates shall be tested on the inside of the tank by applying a solution film to the joints and pulling a partial vacuum of at least 3 lbf/in.² gauge by means of a vacuum box with a transparent top. As an alternate to vacuum box testing, a suitable tracer gas and compatible detector can be used to test the integrity of welded bottom joints for their entire length if an appropriate tracer gas testing procedure has been reviewed and approved by the purchaser.

7.18.2.5 Tanks with anchors shall be grouted (if required by design) and anchor retainers shall be attached.

7.18.2.6 After all the welding has been examined and tested and all defective welding disclosed by such examination and testing has been repaired and retested, the tank shall be filled with air to a pressure of 2 lbf/in.² gauge or one-half the pressure P_g for which the vapor space at the top of the tank is designed, whichever pressure is smaller. A solution film shall be applied to all joints in the tank wall above the high liquid (capacity) design level. If any leaks appear, the defects shall be removed and rewelded, and the applicable preliminary tightness tests specified shall be repeated. When anchors are not provided near the boundary of contact to hold down a dished tank bottom resting directly on the tank grade, the bottom at this boundary may be rise slightly off the foundation during the tightness test when air pressure is in the tank. In this case, sand shall be tamped firmly under the bottom to fill the gap formed while the tank is under pressure (see 7.18.8).

7.18.3 Combination Hydrostatic-Pneumatic Tests

7.18.3.1 Tanks that have not been designed to be filled with liquid to a test level higher than their specified capacity level (see 5.3.1.2) shall be subjected to combination hydrostatic-pneumatic pressure tests in accordance with the procedure described in 7.18.3.2 through 7.18.3.5.

7.18.3.2 After the preliminary tightness tests specified in 7.18.4 have been completed, the pressure-vacuum relief valve or valves shall be blinded off. With the top vented to the atmosphere to prevent accumulation of pressure, the tank shall be filled with water to its high liquid (capacity) design level (see 7.18.7). Tank anchor retainers shall be adjusted to a uniform tightness after the tank is filled with water. If the pressure-vacuum valve or valves are not available at the time of the test, the tank connections may be blinded off and the test procedure continued by agreement between the purchaser and the manufacturer. With the vents at the top of the tank closed, air shall be injected slowly into the top of the tank until the pressure in the vapor space is about one-half the pressure P_g , for which this space is designed. The air pressure shall be increased slowly until the pressure in the vapor space is 1.25 times the pressure, P_g , for which the space is designed.

7.18.3.3 An air test introduces some hazard. In view of the large amount of air that will be present in the tank during this test, no one should be permitted to go near the tank while pressure is being applied for the first time during this test. While the pressure in the tank exceeds the pressure for which the vapor space is designed, the inspections should be made at a reasonable distance from the tank using field glasses as required for close-up observation of particular areas.

7.18.3.4 As the pressure is being increased, the tank shall be inspected for signs of distress. The maximum test pressure of 1.25 times the vapor space design pressure shall be held for at least one hour, after which the pressure shall be released slowly and the blinds shall be removed from the pressure-vacuum relief valves. The operation of the relief valves shall then be checked by injecting air into the top of the tank until the pressure in the vapor space equals the pressure, P_g , for which this space is designed, at which time the relief valves shall start to release air.

7.18.3.5 This latter pressure shall be held for a sufficient period of time to permit a close visual examination of all joints in the walls of the tank and of all welding around manways, nozzles, and other connections. As part of this examination, a solution film shall be applied to all of the welding involved above the high liquid (capacity) design level for which the tank is designed.

7.18.4 Complete Hydrostatic Tests

7.18.4.1 Tanks that have been designed and constructed to be filled with liquid to the top of the roof (see 5.3.1.2) shall be subjected to full hydrostatic tests in accordance with the procedure prescribed in 7.18.4.2 and 7.18.4.4, in lieu of the procedure specified in 7.18.3.

7.18.4.2 Following the test preliminaries called for in 7.18.2, the pressure-vacuum relief valve or valves shall be blinded off; with the top of the tank vented to the atmosphere, the tank shall be filled with water to the top of the roof (see 7.18.7) while allowing all air to escape to prevent the accumulation of pressure. If the pressure-vacuum relief valve or valves are not available at the time of the test, the tank connections may be blinded off and the test procedure continued by agreement between the purchaser and the manufacturer. The vents used during water filling of the tank shall then be closed, and the pressure in the tank shall be increased slowly until the hydrostatic pressure under the topmost point in the roof is 1.25 times the pressure, P_g , which the vapor space is designed to withstand when in operation with the tank filled to its specified high liquid (capacity) level.

7.18.4.3 This test procedure shall be held for at least one hour. The hydrostatic pressure under the topmost point in the roof shall then be reduced to the pressure, P_g , for which the vapor space is designed and shall be held at this level for a

sufficient time to permit close visual inspection of all joints in the walls of the tank and all welding around manways, nozzles and other connections.

7.18.4.4 The tank shall then be vented to atmosphere, the water level shall be lowered below the inlets to the pressure-relief valves, and the blinds shall be removed from the relief valves. The operation of the relief valves shall then be checked by injecting air into the top of the tank until the pressure in the vapor space equals the pressure, P_g , for which this space is designed, at which time the relief valves shall start to release air.

7.18.5 Partial-Vacuum Tests

7.18.5.1 Following the tests specified in 7.18.3 (or in 7.18.4) where this latter procedure has been used), the pressure in the vapor space of the tank shall be released and a manometer shall be connected to this space. The ability of the upper part of the tank to withstand the partial vacuum for which it is designed and the operation of the vacuum-relief valve or valves on the tank shall then be checked by withdrawing water from the tank, with all vents closed, until the design partial vacuum is developed at the top of the tank and by observing the differential pressure at which the valve or valves start to open. The vacuum-relief valve or valves must be of a size and be set to open at a partial vacuum closer to the external atmospheric pressure than the partial vacuum for which the tank is designed. The partial vacuum in the tank should never exceed the design value (see Appendix K).

7.18.5.2 After completing 7.18.5.1, the withdrawal of water from the tank shall be continued, with the vents closed and without exceeding the specified maximum partial vacuum in the top of the tank, until the level in the tank reaches one-half the high liquid (capacity) level for which the tank is designed. Alternatively, to speed up the withdrawal of water to the degree thought expedient, the vents may either be kept closed and air pressure not exceeding P_g at the top of the tank applied, or the vents may be opened during most of this interval if in either procedure they are closed long enough before the level in the tank reaches half height for the specified partial vacuum to be developed by the time the level of the water reaches half height.³⁶ Air shall then be again injected into the tank until the pressure above the water level equals the pressure, P_g , for which the vapor space at the top of the tank is designed.

³⁶These provisions presuppose that an ejector or vacuum pump is not available for drawing a partial vacuum on the tank. However, if such equipment is available, it may be used: vents may be opened during the entire period while the water level is being lowered; and the sequence of the vacuum and pressure test may be reversed if either the tank manufacturer or the purchaser so selects.

7.18.5.3 Careful observation shall be made under all of the specified conditions of loading, as well as with atmospheric pressure above the surface of the water when the level is at half height, to determine whether any appreciable changes occur in the shape of the tank (see 7.18.8). In the case of a vertical tank with cylindrical sidewalls, no tests are required with the water level at half height; in this case, the tests specified in 7.18.5.4 shall be applied immediately after the first vacuum test specified in 7.18.5.

7.18.5.4 The water remaining in the tank shall then be withdrawn and when the tank is substantially empty, a vacuum test comparable to that specified in 7.18.5.1, except with regard to the level of water in tank, shall be applied to the tank. After this, air shall again be injected into the tank until the pressure in the tank equals the pressure, P_g , for which the vapor space at the top of the tank is designed. Observations shall be made, both with the specified partial vacuum and with the vapor space design pressure above the surface of the water, to determine whether any appreciable changes in the shape of the tank occur under either condition of loading. In the case of a tank whose dished bottom rests directly on the tank grade, if the bottom rises slightly off the foundation during the pressure test, sand shall be tamped firmly under the bottom to fill the gap formed while the tank is under pressure (see 7.18.2.6 and 7.18.8).

7.18.6 Visual Inspection

Upon completion of all the foregoing tests, the pressure in the tank shall be released and a thorough visual inspection shall be made of both the inside and outside of the tank, giving particular attention to all internal ties, braces, trusses, and their attachments to the walls of the tank. Anchors shall be checked for snug tightness and adjusted if required. Anchor threads shall be fouled by peening or tack welding to prevent loosening. In lieu of thread fouling, double nuts may be used.

7.18.7 Rate of Water Filling and Water Temperature

The rate at which water is introduced into a tank for a hydrostatic test shall not exceed 3 ft of depth per hour. The foundation, venting equipment, or other conditions may limit the water filling to a lower rate. Pressure shall not be applied above the surface of the water before the tank and its contents are at about the same temperature. The temperature of the water used in the tests should be not less than 60°F whenever practicable.

7.18.8 Changes in Tank Shape

If in any of the foregoing tests there is an excessive rise of the bottom of the tank around the boundary of contact with grade, or off its foundations, or if any of the specified

conditions of test loading cause other appreciable changes in the shape of the tank, the design shall be reviewed and means shall be provided in the tank for holding the shape within permissible limits under all conditions of loading.

7.18.9 Additional Tests

The tests prescribed in 7.18 are believed to be sufficient for most tanks constructed according to these rules; if, in the opinion of the designer, additional tests are needed to investigate the safety of a tank under certain other conditions of loading, as determined from the design computations, these tests shall be made on the tank involved in addition to the tests specified in this standard.

7.18.10 Tanks Subject to Corrosion

In the case of tanks that are subject to corrosion on some or all of their wall plates or on internal ties, braces, or other members that carry pressure-imposed loads, the test specified in 7.18.3 (or the test specified in 7.18.4, if applicable) should be repeated periodically during the lives of the tanks as the metal added for corrosion allowance disappears.

7.19 PROOF TESTS FOR ESTABLISHING ALLOWABLE WORKING PRESSURES

7.19.1 General

Because pressures in liquid storage tanks built according to these rules vary quite markedly from the tops to the bottoms of the tanks, proof testing of these tanks presents problems not usually encountered in the construction of unfired pressure vessels—especially where the parts under investigation are located near the bottoms of the tanks. The principal difficulty is devising a test or series of tests that will reliably establish the working pressure that can be permitted on the part of the unproven design without, at the same time, imposing hazardous conditions on other parts located at higher levels in the tank. Another possible complication is that, because of the large volumetric capacities of these tanks, it may not be practicable to completely remove all pressure loading from the part under investigation in order to obtain strain-gauge readings under no-load conditions after successive increments of pressure have been applied in the test procedure. Also, in the case of tanks designed for storing only gases or vapors, water cannot be used as a testing medium.

7.19.2 Use of Design Rules

The design rules and formulas given in the design section of these rules will be found to cover all of the more common designs of vertical tanks, shapes of openings, and so forth. The absence of a standard proof-test procedure will not greatly affect the usefulness of these rules. Whether a standard proof-test procedure can be devised that will be applicable to all shapes, sizes and types of tanks that might be

constructed under these rules is not known, but it is recognized that in special cases a manufacturer may be able to propose a proof-test procedure that would be satisfactory for a particular tank (see 7.19.3).

7.19.3 Developing Proof Tests

04 | **7.19.3.1** Pending development of an approved standard proof-test procedure, whenever a manufacturer desires to construct a tank that will be marked as specified in 8.1 and embodies any features that should be proof-tested because of the provisions of 5.1.5 and 5.13.5.3 or any other provisions of these rules that call for proof test or strain-gauge surveys, the manufacturer shall develop specifications for an appropriate proof-test procedure for the tank and obtain approval from the purchaser or the purchaser's agent, preferably before starting fabrication of the tank. Such specifications shall cover all important details of the proposed proof-test procedure, including but not necessarily limited to a description of how the tank would be prepared for the test, how the test loadings would be applied, what medium would be used for the test, the increments in which the loadings would be applied, what kind of data would be taken, how the test results would be interpreted, and the basis upon which allowable working pressures would be established for the part or parts under investigation. In seeking approval of such a test, the manufacturer shall furnish full information concerning the general construction of the proposed tank, the design and location of the part or parts of uncertain strength, the conditions of loading to which the tank would be subjected in service, and other pertinent matters.

04 | **7.19.3.2** In case the purchaser or the purchaser's agent does not approve a special proof-test procedure, the tank in question shall not be marked as specified in 8.1, nor shall a tank be so marked after failing to satisfactorily pass a special proof test that has been so approved, unless the tank is

strengthened in a manner acceptable to the inspector and is then retested and satisfactorily passes the second proof test.

7.20 TEST GAUGES

7.20.1 An indicating gauge shall be connected directly to the topmost part of the roof on the tank under test. In the case of a tank which is designed for the storage of gases or vapors alone and is to be tested only with air, the gauge may be connected to the tank at some lower level. If the indicating gauge is not readily visible to the operator who is controlling the pressure applied, an additional indicating gauge shall be provided where it will be visible to the operator throughout the test. Means shall be provided to ensure that the required test pressure will not be exceeded.

7.20.2 A recording gauge shall also be used on each tank, and a record shall be kept of the pressures during all stages of the tests. This gauge shall be connected either to the piping that leads to the indicating gauge or directly to the tank at a point near the indicating gauge connection.

7.20.3 Indicating gauges used during the tests shall be calibrated against a standard deadweight tester before the tests are started.

7.20.4 If at any time during a test there is reason to believe that a gauge is in error, its calibration shall be checked. If the gauge is in error, it should preferably be adjusted to read correctly, or a calibration curve may be made to indicate the correct pressures for the readings indicated by the gauge.

7.20.5 In all cases in which a gauge is mounted at a level lower than its connection to the tank or lower than some part of the piping that leads to the gauge, suitable precautions shall be taken to prevent accumulation of any static head of condensed moisture (or water from other sources) in the piping leads above the level of the gauge. Not preventing this would result in erroneous readings.

**For Committee
Use Only**

SECTION 8—MARKING

8.1 NAMEPLATES

8.1.1 A tank made in accordance with this standard shall be identified by a nameplate similar to that shown in Figure 8-1. The nameplate shall indicate, by means of letters and numerals not less than $\frac{5}{32}$ in. high, the following information:

- a. API Standard 620.
- b. Applicable appendix.
- c. Year completed.
- d. Applicable edition and revision number of this publication.
- e. Nominal diameter and nominal height, in ft and in.³⁷
- f. Nominal capacity, in barrels of 42 gallons per barrel.³⁷
- g. Design liquid level, in ft and in.³⁷
- h. Design specific gravity of liquid.
- i. Maximum test level for hydrostatic test with water, in ft and in.³⁷
- j. Design pressure for gas or vapor space at the top of the tank, in lbf/in.² gauge.³⁷
- k. Design metal temperature, in °F.³⁷ (Use the lower of the following temperatures:
 1. The temperature described in 4.2.1, or
 2. The minimum design temperature of product storage given by the purchaser for refrigerated product tanks.)
- l. Purchaser's tank number.
- m. Maximum operating temperature, which shall not exceed 250°F.³⁷
- n. The name of the manufacturer with a serial number or contract number to identify the specific tank.
- o. If thermal stress relief is applied to a part in accordance with 5.25 or R.7.3, the nameplate shall be marked "SR," and the part shall be identified on the manufacturer's certificate.
- p. The material specification number for each shell course.

8.1.2 On request by the purchaser or at the discretion of the manufacturer, additional pertinent information may be shown on the nameplate. The size of the nameplate may be increased accordingly.

8.1.3 The nameplate shall be attached to the tank shell adjacent to a manhole or to a manhole reinforcing plate immediately above the manhole. A nameplate that is placed directly on the shell plate or reinforcing plate shall be attached by continuous welding or brazing all around the plate. A nameplate that is riveted or otherwise permanently attached to an auxiliary plate of ferrous material shall be attached to the tank shell plate or reinforcing plate by continuous welding. The nameplate shall be of corrosion-resistant metal.

8.1.4 When a tank is fabricated and erected by a single organization, that organization's name shall appear on the nameplate as both fabricator and erector.

8.1.5 When a tank is fabricated by one organization and erected by another, the names of both organizations shall appear on the nameplate, or separate nameplates shall be applied by each.

8.2 DIVISION OF RESPONSIBILITY

Unless otherwise agreed upon, when a tank is fabricated by one organization and erected by another, the erection manufacturer shall be considered as having the primary responsibility. The manufacturer shall make certain that the materials used in the fabrication of the components and in the construction of the tank are in accordance with all applicable requirements.

8.3 MANUFACTURER'S REPORT AND CERTIFICATE

8.3.1 Upon completion of all tests and inspections on each tank, the manufacturer shall prepare a report summarizing all the data on the tank, including foundations (if they are within the manufacturer's scope of responsibility) and shall attach to the report all drawings and charts as required by other paragraphs in this section of the rules (see 7.13 and Appendix M).

8.3.2 The manufacturer shall furnish and fill out a certificate for each tank (such as that shown in Figure M-5), attesting that the tank has been constructed according to the rules in this standard. This certificate shall be signed by the manufacturer and the purchaser's inspector. This certificate, together with the nameplate or markings placed on the tank, shall guarantee that the manufacturer has complied with all applicable requirements of these rules.

8.3.3 If the purchaser so requests, the manufacturer shall attach to the report copies of the records of the qualification test of welding procedures, of welders, and/or of welding operators (see 6.7 and 6.8).

8.4 MULTIPLE ASSEMBLIES

In the case of assemblies that consist of two or more tanks or compartments designed and built according to the rules of this standard, each tank or compartment in the assembly shall be marked separately, or the markings may be grouped at one location and arranged so that the data for the separate compartments can be identified. Removable pressure parts shall be marked to identify them with the tank to which they belong.

³⁷Unless other units are specified by the purchaser.

API STANDARD 620			
APPENDIX	<input type="text"/>	YEAR COMPLETED	<input type="text"/>
EDITION	<input type="text"/>	ADDENDUM NUMBER	<input type="text"/>
NOMINAL DIAMETER	<input type="text"/>	NOMINAL HEIGHT	<input type="text"/>
NOMINAL CAPACITY	<input type="text"/>	DESIGN LIQUID LEVEL	<input type="text"/>
DESIGN SPECIFIC GRAVITY	<input type="text"/>	MAXIMUM TEST LEVEL	<input type="text"/>
DESIGN PRESSURE	<input type="text"/>	DESIGN METAL TEMP.	<input type="text"/>
PURCHASER'S TANK NO.	<input type="text"/>	MAXIMUM OPERATING TEMP.	<input type="text"/>
MANUFACTURER'S SERIAL NO.	<input type="text"/>	PARTIAL STRESS RELIEF	<input type="text"/>
MANUFACTURER	<input type="text"/>		
SHELL COURSE		MATERIAL	

Figure 8-1—Nameplate

For Construction Use Only

SECTION 9—PRESSURE- AND VACUUM-RELIEVING DEVICES

9.1 SCOPE

The manufacturer or purchaser shall equip tanks constructed within the pressure limits of these rules with pressure-relieving and emergency vacuum-relieving valves, or other equivalent permissible devices, as a means of safeguarding the storage and adjacent equipment involved (see 9.6.1.2 and Appendix N).

9.2 PRESSURE LIMITS

04 | **9.2.1** Tanks constructed according to these rules shall be protected by automatic pressure-relieving devices that will prevent the pressure at the top of the tank from rising more than 10% above the design pressure except as provided in 9.2.2 (see Appendix K).

04 | **9.2.2** Where an additional hazard can be created by the exposure of the tank to accidental fire or another unexpected source of heat external to the tank, supplemental pressure-relieving devices shall be installed. These devices shall be capable of preventing the pressure from rising more than 20% above the design pressure. A single pressure-relieving valve may be used if it satisfies the requirements of this paragraph and 9.2.1.

9.2.3 Vacuum-relieving devices shall be installed to permit the entry of air (or other gas or vapor is so designed) to avoid collapse of the tank wall if this could occur under natural operating conditions. These devices shall be located on the tank so that they will never be sealed off by the contents of the tank. Their size and pressure (or vacuum) setting shall be such that the partial vacuum developed in the tank at the maximum specified rate of air (or gas) inflow will not exceed the partial vacuum for which the tank is required to be designed (see 5.10.5).

9.3 CONSTRUCTION OF DEVICES

Pressure- and vacuum-relieving valves shall be constructed of materials that are not subject to excessive corrosion for the intended service or subject to sticking at the seat or moving parts under any climatic conditions for which they are supplied.

9.4 MEANS OF VENTING

The applicable rules of Section 5.4 in API Std 2000 shall govern.

9.5 LIQUID RELIEF VALVES

A tank, which is likely to operate completely filled with liquid, shall be equipped with one or more liquid relief valves at the top of the roof, unless otherwise protected against over-

pressure. When such valves are, in effect, supplementary relief devices, they may be set at a pressure not greater than 1.25 times the design pressure. Because the relief valve at the pump, which provides the inflow of liquid to the tank, is set at a pressure greater than 1.25 times the design pressure of any tank that may be built under these rules, provision should be made for preventing overfilling of the tank by a self-closing float valve, by some practicable pilot-valve control, or by any other proven device.

9.6 MARKING

9.6.1 Safety and Relief Valves

9.6.1.1 Each safety and relief valve $\frac{1}{2}$ -in. pipe size and larger shall be plainly marked by the manufacturer with the required data in such a way that the marking will not be obliterated in service. Smaller valves are exempted from marking requirements. The marking may be placed on the valve or on a plate or plates securely fastened to the valve. Valves may be marked with the required data stamped, etched, impressed, or cast on the valve or nameplate. The marking shall include the following:

- Name or identifying trademark of the manufacturer.
- Manufacturer's design or type number.
- Size of valve (pipe size of the valve inlet).
- Set pressure, in lbf/in.² gauge.
- Full open pressure, in lbf/in.² gauge.
- Capacity of valve, in ft³ or air³⁸ per minute (60°F and 14.7 lbf/in.² absolute). See 9.6.1.2.

9.6.1.2 In many installations of tanks constructed according to these rules, the safety- or relief-valve inlet pressure is so low in relation to the outlet pressure that valve capacities predicted on acoustic velocity of flow through the discharge area of the valve (the usual basis for establishing safety-valve ratings) are not attainable. For valves that handle light hydrocarbons or vapors, the condition described will exist if the ratio of the absolute pressure at the valve outlet to the absolute pressure at the valve inlet (set pressure in lbf/in.² gauge times 1.10, plus atmospheric pressure) exceeds a value of approximately 0.6: in such cases, formulas of the type given in Section VIII, Appendix 11, of the ASME Code are not appropriate for computing safety- or relief-valve capacity conversions. Where this condition exists, the valve manufacturer should be consulted concerning the size of the valve or valves required for the desired capacity in terms of the specific gas or vapor to be handled, the set pressure to be employed, and the pressure to be imposed on the outlet of the valve. If atmo-

³⁸In addition, the manufacturer may indicate the corresponding capacity in other fluids.

spheric pressure in the locality where the valve is to be used differs materially from 14.7 lbf/in.² absolute, its normal value should be given in the inquiry to the manufacturer.

9.6.2 Liquid Relief Valves

Each liquid relief valve shall be marked with the following data:

- a. Name or identifying trademark of the manufacturer.
- b. Manufacturer's design or type number.
- c. Size of valve, in in. (pipe size of inlet).
- d. Set pressure, in lbf/in.² gauge.
- e. Full open pressure, in lbf/in.² gauge.
- f. Relieving capacity, in ft³ of water (see Footnote 16) per minute at 70°F.

9.7 PRESSURE SETTING OF SAFETY DEVICES

9.7.1 Except as provided in 9.5 for certain liquid relief valves, the pressure setting of a pressure-relieving device shall in no case exceed the maximum pressure that can exist at the level where the device is located when the pressure at the top of the tank equals the nominal pressure rating for the tank (see 5.3.1) and the liquid contained in the tank is at the maximum design level.

9.7.2 Vacuum-relieving devices shall be set to open at such a pressure or partial vacuum that the partial vacuum in the tank cannot exceed that for which the tank is designed when the inflow of air (or other gas or vapor) through the device is at its maximum specified rate.

For Commitment
Use Only

APPENDIX A—TECHNICAL INQUIRY RESPONSES

A.1 Introduction

API will consider written requests for interpretations of Std 620. API staff will make such interpretations in writing after consulting, if necessary, with the appropriate committee officers and committee members. The API committee responsible for maintaining API Std 620 meets regularly to consider written requests for interpretations and revisions and to develop new criteria as dictated by technological development. The committee's activities in this regard are limited strictly to interpretations of the standard and to the consideration of revisions to the present standard on the basis of new data or technology. As a matter of policy, API does not approve, certify, rate, or endorse any item, construction, proprietary device, or activity, and accordingly, inquiries that require such consideration will be returned. Moreover, API does not act as a consultant on specific engineering problems or on the general understanding or application of the standard. If it is the opinion of the committee, based on the inquiry information submitted, that the inquirer should seek other assistance, the inquiry will be returned with the recommendation that such assistance be obtained. All inquiries that do not provide the information needed for the committee's full understanding will be returned.

A.2 Inquiry Format

A.2.1 Inquiries shall be limited strictly to requests for interpretation of the standard or to the consideration of revisions to the standard on the basis of new data or technology. Inquir-

ies shall be submitted in the format described in A.2.2 through A.2.5.

A.2.2 The scope of an inquiry shall be limited to a single subject or a group of closely related subjects. An inquiry concerning two or more unrelated subjects will be returned.

A.2.3 An inquiry shall start with a background section that states the purpose of the inquiry, which would be either to obtain an interpretation of the standard or to propose a revision to the standard. The background section shall concisely provide the information needed for the committee's understanding of the inquiry (with sketches as necessary) and shall cite the applicable edition, revision, paragraphs, figures, and tables.

A.2.4 After the background section, an inquiry's main section shall state the inquiry as a condensed, precise question, omitting superfluous background information and, where appropriate, posing the question so that the reply could take the form of "yes" or "no" (perhaps with provisos). This inquiry statement should be technically and editorially correct. If the inquirer believes a revision to the standard is needed, recommended wording shall be suggested.

A.2.5 The inquirer shall include his name and mailing address. The inquiry should be typed; however, legible handwritten inquiries will be considered. Inquiries should be submitted to the director of the Standards Department, American Petroleum Institute, 1220 L Street, N.W., Washington, D.C. 20005-4070. standards@api.org

Following are selected responses to requests for interpretation API Std 620 requirements. A more extensive listing of interpretations can be found on the API website at <http://api-ep.api.org> under the "Committees/Standards Development" section. Additional information on technical inquiries can be found in Appendix A.

SECTION 1.2 COVERAGE

620-I-10/00

Question 1: Does 1.2.1 prevent tanks with umbrella roofs and eccentric cones, from being marked as being in accordance with API Std 620?

Reply 1: No.

Question 2: Does 1.2.1 prevent tanks with flat bottoms from having a slope?

Reply 2: No.

TABLE 4-1 MINIMUM REQUIREMENTS FOR PLATE SPECIFICATIONS TO BE USED FOR DESIGN METAL TEMPERATURES

620-I-06/00

Question 1: Referring to API Std 620, is it permissible to utilize plate materials at a design metal temperature and thickness combination which are outside the limits contained in Table 4-1 if impact testing is performed?

Reply 1: No.

Question 2: Does API Std 620 allow impact testing to be performed in lieu of normalizing for combinations of plate material grade, thickness and design metal temperature that require normalizing?

Reply 2: No.

Question 3: May impact testing be utilized in lieu of normalizing for plate materials where Table 4-1 of API Std 620 and the ASTM specification require normalizing e.g., A 516 with thickness greater than 1¹/₂ in.?

Reply 3: No.

SECTION 5 DESIGN

620-I-03/01

Question: Does API Std 620 contain any weld spacing requirements for fillet welds?

Reply: The API committee responsible for this standard has created an agenda item to address this issue. Any changes resulting from this agenda item will appear in a future edition or addendum to API Std 620.

SECTION 5.1.1 SCOPE OF RULES

620-I-05/02

Background: API Standard 620, Tenth Edition, Section 1.2.1, states, "This standard does not cover design procedures for tanks that have walls shaped in such a way that the walls cannot be generated in their entirety by the rotation of a suitable contour around a single vertical axis or revolution." This statement would appear to indicate that there are no design procedures presented in this standard for umbrella roofs, eccentric cone roofs and bottoms, and bottoms sloped to one side. For example, Sections 1.1, 1.2.5, 5.1.1, and 5.1.5, among others, indicate that subject to stated restrictions, designs that will be as safe as those provided by the standard may be used. This inquiry seeks to confirm this interpretation. I am trying to clarify Inquiry 620-I-10/00.

Question: Are umbrella roofs, eccentric cone roofs and bottoms, and bottoms sloped to one side, among those designs for which API 620 does not present design rules as noted in Section 5.1.1?

Reply: Yes.

SECTION 5.3 PRESSURES USED IN DESIGN

620-I-03/03

Question: Does a coned roof have a minimum thickness similar to that noted for the sidewall in 5.10.4.1 and bottom in 5.9.4.2 (eighth edition).

Reply: Yes, see 5.3.

SECTION 5.10.5 EXTERNAL PRESSURE LIMITATIONS

620-I-04/03

Question: What are the requirements for vacuum testing tanks built to API 620?

Reply: Tanks built to API 620 cannot be designed for vacuum, refer to API 620 Section 5.10.5.2. Therefore, the tanks are not tested for vacuum.

SECTION 5.12 DESIGN OF ROOF AND BOTTOM KNUCKLE REGIONS AND COMPRESSION-RING GIRDERS

620-I-02/00

Question 1: Item (c) of API Std 620, 5.12.5.2 states if the compression area required is not provided in the compression-ring region with minimum thickness plates, then the additional required compression area provided in the composite corner compression region should ideally lie in the horizontal plane of the corner formed by the two members. In no case shall the centroid be off the plane by more than 1.5 times the average thickness of the two members intersecting at the corner.

Does this mean that the horizontal centroid of the additional angle excluding the effective shell (W_h) and roof (W_c) as per Fig. 5-6 detail a, b, c, d, h and i, or the horizontal centroid of the total cross-sectional of composite corner compression region lies ideally in the horizontal plane of the corner formed by two members? In addition, shall the centroid of the composite corner compression region not be off the horizontal plane by more than 1.5 times the average thickness of the shell (t_c) and roof (t_h) or of the two members of any additional angle?

Reply 1: The horizontal centroid of the total cross-sectional area of the composite corner compression region shall not be off the horizontal plane formed by the intersection of shell and roof by more than 1.5 times the average thickness of the shell (t_c) and roof (t_h). If an angle is welded to the top of the shell and the roof attaches to the angle, then t_c shall be equal to the thickness of the angle and the corner is the intersection of the angle and the roof.

Question 2: Is it required to use a top angle for tanks designed per API Std 620 and API Std 650, F.7.2 and F.7.3 for the case where the effective area of shell and roof can resist the Q-force and the horizontal projection of W_h is at least $0.015R_c$ according to API Std 620, 5.12.5.2?

Reply 2: No.

SECTION 5.15 INSPECTION OPENINGS

620-I-05/01

Question: Does 5.15, permit the two openings to be one opening in the roof and one opening at the bottom of the side wall?

Reply: Yes. API Std 620 does not stipulate the location of the two openings.

SECTION 5.17 REINFORCEMENT OF MULTIPLE OPENINGS

620-I-03/01

Question: Does 5.17.1b require the spacing between a fillet weld and the shell plate fillet weld be spaced some specified distance apart?

Reply: The API committee responsible for this standard has issued an agenda to address this issue. Any changes resulting from this agenda item will appear in a future edition or addendum to API Std 620.

SECTION 5.26 RADIOGRAPHY

620-I-02/01

Question: Does 5.26.3.2 require that the butt joints of the dome steel roof compression ring be radiographed?

Reply: Yes, unless exempted by 5.26.2.

FIGURE 5-6 PERMISSIBLE AND NONPERMISSIBLE DETAILS OF CONSTRUCTION FOR A COMPRESSION-RING REGION

620-I-11/00

Question: Is the width of lap of the roof panels, onto or beneath the compression ring plate, prescribed in Figure 5-6 Details e, f, f-1, and g?

Reply: No. See 5.22.1.5.

620-I-12/00

Question: May the lap welds of the roof panels, onto or beneath the compression ring plate, prescribed in Figure 5-6, Details e, f, f-1, and d be double-lap welds or single-lap welds if the appropriate joint efficiency and inspection are applied?

Reply: Yes.

620-I-13/00

Question: May the roof be butt-welded to the compression ring as an alternative to the lap weld shown in Figure 5-6, Details e, f, f-1, and g, if all requirements for circumferential butt welds are met?

Reply: Yes.

620-I-14/00

04] Question 1: Does the expression, $w_h - L \leq 16t$, apply to Figure 5-6, Detail e as well as to Figure 5-6, Details f and f-1?

Reply 1: Yes.

Question 2: Does the outward extension limitation at a maximum of $16t$ of the plate compression ring in Figure 5-6, Detail e apply as well to Figure 5-6, Details f and f-1?

Reply 2: Yes. An agenda item will be issued by the committee to clarify Figure 5-6.

620-I-15/00

Question 1: Is the dimension, w_h , of Figure 5-6, Details f and f-1, a limitation on the greatest inward physical projection that a plate compression ring may have?

Reply 1: No.

Question 2: Is the dimension, w_h , of Figure 5-6, Details f and f-1, a limitation on the "effective" portion of the plate compression ring that may be considered as contributing to the required cross-section area, A_c ?

Reply 2: Yes.

Question 3: Is the dimension, w_h , of Figure 5-6, Details f and f-1 also applicable to Figure 5-6, Details e and g?

Reply 3: Yes.

620-I-16/00

Question: Are the roof plates of Figure 5-6, Detail e not permitted to contribute to the required cross-sectional area of the compression region because of the lap weld between the roof and the compression-ring as stated in Section 5.12.2 and Note 17?

Reply: Yes.

TABLE 5-2 MAXIMUM ALLOWABLE EFFICIENCIES FOR ARC-WELDED JOINTS

620-I-13/00

Question: API Std 620, Table 5-2 lists single welded butt joints with backing strip as having 75% basic joint efficiency. A spot radiographed joint is also listed at 75%. Are all single welded butt joints with permanent metallic backing strip not more than 1¹/₄ in. thick required to be spot radiographed as a minimum?

Reply: Yes, however radiography is not required for E = 0.7 if nonmetallic or temporary metallic backing strips are used.

620-I-01/01

Question: Does the magnetic particle examination covered by Note 3 of Table 5-2 in API Std 620 apply to the butt weld of a nozzle neck to a weld neck flange?

Reply: No.

SECTION 6.4 FORMING SIDEWALL SECTIONS AND ROOF AND BOTTOM PLATES

620-I-01/00

Question: Does API Std 620 require that shell plates be rolled prior to erection to the design radius?

Reply: No, unless forming impairs the mechanical properties. Refer to 6.4.

SECTION 6.5 DIMENSIONAL TOLERANCES

620-I-07/00

Question 1: Does API Std 620 address the maximum local deviation/weld distortion on a 6 mm thick bottom plate resulting from the full penetration butt-welds in transverse and longitudinal butts?

Reply 1: No.

SECTION 7.17 RADIOGRAPHIC EXAMINATION REQUIREMENTS

620-I-02/01

Question: If the requirements of magnetic particle testing of 7.17.1.3 are met, is additional radiographic examination of these joints required?

Reply: No.

SECTION 8.2 DIVISION OF RESPONSIBILITY

620-I-04/01

Question 1: Does the term erector, as used in API Std 620, mean the party that is responsible for field assembly will complete welds on the tanks during that assembly?

Reply 1: Yes.

Question 2: For tanks built to API Std 620 that are completely welded out in a fabricator's facility with field installation consisting of another company setting and anchoring without performing any welds on the tanks, does the responsibility for the hydrostatic test rest with the fabricator or the installer?

Reply 2: API Std 620 covers field-erected tanks, not shop-built tanks. See Section 1.1 of API Std 620. Appendix J of API Std 650 prescribes requirements for shop-built tanks, including testing and division of responsibility for same.

APPENDIX L SEISMIC DESIGN OF STORAGE TANKS

620-I-17/00

Question 1: Is vertical acceleration considered in API Std 620 Appendix L.

Reply 1: No.

Question 2: Please advise how to consider vertical acceleration.

Reply 2: API does not provide consulting on specific engineering problems or on the general understanding of its standards. We can only provide interpretations of API Std 650 requirements or consider revisions based on new data or technology. You may wish to review a procedure in AWWA D100-96 for further information.

Question 3: If specified, should vertical earthquake be taken into consideration?

Reply 3: Yes.

APPENDIX N INSTALLATION OF PRESSURE-RELIEVING DEVICES

620-I-04/02

Background: API 620, Appendix N, states discharge piping on the outlet side from pressure-relieving devices must have a minimum area equal to the valve outlet. In API Std. 2000, Section 4.5.3, no mention is made of this constraint on the minimum area required; only a mention of the back-pressure being included in the relief device sizing calculations.

Question: Does API 2000 allow you not to comply with the discharge piping area requirements of API 620 Appendix N?

Reply: No, the requirements of both standards must be met.

APPENDIX Q LOW-PRESSURE STORAGE TANKS FOR LIQUEFIED HYDROCARBON GASSES

620-I-01/02

Question: For low-temperature and cryogenic tanks constructed under the provisions of API 620, Appendix Q, when circumferential joints are welded by a technique where the weld is produced by a machine but it is constantly observed and various adjustments are periodically made by a welding operator, does Q.6.6.4 require production weld tests for the circumferential welds?

Reply: No.

APPENDIX R LOW-PRESSURE STORAGE TANKS FOR REFRIGERATED PRODUCTS

620-I-01/02

Question: For low-temperature and cryogenic tanks constructed under the provisions of API 620, Appendix R, when circumferential joints are welded by a technique where the weld is produced by a machine but it is constantly observed and various adjustments are periodically made by a welding operator, does R.6.3.4 require production weld tests for the circumferential welds?

620-I-11/02

Reply: No.

Question 1: Does Figure R-2 of API 620 represent all the requirements of R.7.6.1?

Reply 1: No.

Question 2: Does R.7.6.1 apply to horizontal shell joints?

Reply 2: Yes.

620-I-12/02

Question 1: Referring to API 620, Appendix R, do both longitudinal and circumferential joints have to be 100% radiographed?

Reply 1: No.

Question 2: Referring to API 620, Appendix R, do only longitudinal joints have to be radiographed?

Reply 2: Yes.

Question 3: Is there any connection between R.7.6.1 and the conditions mentioned in Section 5.2.6?

Reply 3: Section 5.2.6 applies, unless there are conflicts with R.7.6., which would then control.

04

For Committee
Use Only

**For Committee
Use Only**

APPENDIX B—USE OF MATERIALS THAT ARE NOT IDENTIFIED WITH LISTED SPECIFICATIONS

B.1 General

Plates and lengths of seamless or welded pipe that are not completely identified with any listed specification may, under the conditions described in B.2 through B.7, be used in the construction of tanks covered by this standard. Whenever the term listed specifications appears in this appendix, it shall refer to a material specification that is listed as being approved for this standard.

B.2 Materials with Authentic Test Records

If an authentic test record for each heat or heat-treating lot of material is available that proves it to have chemical requirements and mechanical properties within the permissible range of an ASTM specification listed in this standard, the material may be used. If the test requirements of the listed specification are more restrictive than any of the specifications or authentic tests that have been reported for the material, the more restrictive tests shall be made in accordance with the requirements of a comparative listed specification, and the results shall be submitted to the purchaser for approval.

B.3 Materials without Authentic Test Records

If an authentic test record is not available or if all of the material cannot be positively identified with the test record by legible stamping or marking, the material shall be tested as described in B.3.1 and B.3.2.

B.3.1 PLATE

Each plate shall be subjected to the chemical check analysis and physical tests required in the designated specification, with the following modifications: The carbon and manganese contents shall be determined in all check analyses. The purchaser shall decide whether these contents are acceptable when the designated specification does not specify carbon and manganese limits. When the direction of rolling is not definitely known, two tension specimens shall be taken at right angles to each other to form a corner of each plate, and one tension specimen shall meet the specification requirements.

B.3.2 PIPE

Each length of pipe shall be subjected to a chemical check analysis and physical tests which satisfy the purchaser that all of the material is properly identified with a given heat or heat-treatment lot and that the chemical and physical requirements of the designated specification are complied with. Material specified as suitable for welding, cold bending, close coiling, and so forth shall be given check tests which satisfy the purchaser that each length of material is suitable for the fabrication procedure to be used.

B.4 Marking of Identified Material

After material has been properly identified with a designated specification and the purchaser has been satisfied that the material complies with the specification in all respects, the testing agency shall stencil or otherwise mark, as permitted by the material specification, a serial S-number on each plate or each length of pipe (or as alternately provided for small sizes in the specification) in the presence of the purchaser.

B.5 Report on Tests of Non-Identified Materials

Suitable report forms that are clearly marked as being a report on tests of non identified materials shall be furnished by the tank manufacturer or testing agency, properly filled out, certified by the testing agency, and approved by the purchaser.

B.6 Acceptance or Rejection

The purchaser shall have the right to accept or reject the testing agency or the test results.

B.7 Requirements for Fabrication

The requirements for fabrication that are applicable to the designated specification to which the nonidentified material corresponds shall be followed, and the allowable design stress values shall be those specified elsewhere in this standard for that corresponding specification.

**For Committee
Use Only**

APPENDIX C—SUGGESTED PRACTICE REGARDING FOUNDATIONS

C.1 Introduction

The practices suggested in this section are intended only to supply information to those who are not fully conversant with the foundation problems of important structures. These practices are in no sense to be taken literally in providing the best design for any particular site.

The experienced judgment of a competent engineer is needed to pass on any but well-proven sites in any locality, barring only the possibility of spot variations. For this reason, the minimum checks of subgrade included in this section will usually prove worthwhile. Such checks may even be superfluous when a qualified geologist has passed on the general area or where the measured settlement of existing structures around the proposed sites, which produce a similar type of loading, confirms the load-bearing capacity to be selected.

No set of rules can cover all possible combinations of subgrade loading conditions. Types of subgrade structures and the final design of the finished installation may be affected by groundwater or local climatic changes.

Many large vertical storage tanks have been built with cylindrical shells and flat bottoms that rest directly on simply prepared subgrade. In the case of unequal settlement, a leveling of the tank and subgrade has forestalled failure. However, for tanks that have formed bottom plates, such as may be built according to this standard, uniformity of support and avoidance of excessive settlement are much more important than they are in the case of flat-bottom, vertical storage tanks. Hence, sites for erection of tanks constructed according to the rules of this standard shall be chosen only after careful consideration and evaluation of the bearing properties of the soil at the locations involved.

C.2 General

For a low-pressure tank in the large sizes covered by this standard, the nature of the subgrade can be of prime importance. Many industrial plants that require such storage are located near large streams, where the areas to be built on are alluvial deposits. These deposits are usually interspersed with gravel and sand, all affected by previous changes in the course of the stream, so that both the character and depth of the composite layers have no uniformity. The recommendations made in this section will therefore omit any reference to rock or even shales and hardpan (cemented gravel) for direct support of masonry footings. Long-standing practices for such conditions are well known.

For large tanks that will rest on or near grade level, proper grade preparation can have an important bearing on bottom corrosion. Tanks erected on poorly drained grades in direct contact with corrosive soils or on heterogeneous mixtures of

different types of soils are subject to electrolytic attack on the bottom side.

Assuming that soil-bearing conditions have been determined to be adequate, the simplest form of foundation is a sand pad laid directly on the earth. All loam or organic material shall be removed and replaced with suitable well compacted material. Often a satisfactory fill material is available at the site. If not, bank run gravel is excellent and is readily compacted.

The grade for the tank shall be elevated slightly above the surrounding terrain to ensure complete drainage from beneath the entire bottom of the tank. Sufficient berm shall be provided to prevent washing away and weathering under the tank bottom. The berm width shall be at least 5 ft. Weathering can be minimized if the berm is subsequently protected with trap rock, gravel, or an asphaltic flashing.

The nature of predictable settlement may determine the choice of the kind of support for large field-assembled tanks that rest directly on a prepared grade, sometimes retained within curb walls, as well as for those tanks that shall be supported on ring walls, pedestals and columns, skirts, or ring girders.

Except in the case of tanks founded on solid rock, hardpan, or similar substances, some amount of settlement is bound to take place. Every reasonable precaution shall be taken to ensure that the settlement will be kept to an acceptable minimum and that any settlement which does occur will be as uniform as possible. Large, and perhaps even moderate, irregularities in settlement may lead to an unbalancing of the loading conditions assumed in the design and possibly to serious distortion of important elements of the tank.

For those locations where the use of piling is the only logical procedure, the piling design factors would be well known to the engineer charged with making the decision for the contractor or owner. Competent guidance may be needed in choosing between a pile that depends on skin friction alone or mainly on end bearing with small credit for lateral support in combination with skin friction for part of the length.

C.3 Design

The designer of these large tanks shall supply the data on superimposed loadings to be assumed for the foundation design or, if there are no foundations, for direct loading on the subgrade. A slab or mat may be provided to support the superstructure and shall be considered to distribute the load more evenly over a lower natural subgrade compared with merely stripping, leveling, and rolling the existing grade.

Foundations and subgrade shall safely carry the weight of the tank and its contents when the tank is filled with water to the highest level required for a hydrostatic test or other water-

loading operations, even though the tank itself may be designed for some lesser density of liquid. However, in cases where the character of the soil justifies it and a competent soil expert advises it, allowance may be made for the relatively short duration and intermittent nature of the water loadings if suitable account is taken of all such loadings that may be expected to occur during the life of the tank, including not only those loadings that are incidental to periodic repetitions of the hydrostatic test in accordance with 7.18 but also water-filling operations for gas-freeing purposes.

For simple spheroids or tanks of similar design, in which the distribution of the imposed weights shifts because the liquid level in combination with the vapor pressure may change the shape of the tank, the designer shall consider the possibility of such a change.

C.4 Soil-Bearing Values

The bearing values selected shall be conservative on the assumption that suitable field tests will be made if borings or test pits, or both, do not give satisfactory information on the depth required.

Determination of the allowable maximum soil-bearing value shall be the responsibility of the purchaser.

C.5 Investigation of Subgrade

On actual tank sites to be used, test borings or test pits, or both, may be made at the direction of a competent engineer who will specify the number and location. They need not be equally spaced but should be laid out to uncover possible weak spots.

Test borings, where required, shall be carried to sufficient depths to disclose any deep-lying soft or insufficiently consolidated strata beneath the surface. If such strata is discovered, its effects on the bearing properties at the surface of the grade shall be carefully evaluated, giving due consideration to the loaded-area size effect of the total area loaded by the tank.

In general, test loadings of subgrade at the bottom of test pits need be resorted to only when such heavy loading as may be imposed by footings for major column supports for spheres or similarly elevated low-pressure tanks is specified. Results may be deceptive if average load-bearing capacity over a considerable area is wanted. All field data shall be recorded with maps, and copies shall be supplied to all engineers concerned with design, erection, and later operation.

C.6 Minimum Depth of Footings

The depth of the bottom of footings shall be determined by local subgrade conditions. The base of these footings shall be placed below the expected frost line, away from any nearby excavations, and below any nearby sewers or piping which, if leaky, could cause serious impairment of the foundation.

C.7 Concrete in Foundations

ACI Standard 318 shall govern the design of all concrete and the specifications for the cement, the aggregate, and the mixing and placing thereof, unless otherwise specified in the contract.

C.8 Installation of Foundations

C.8.1 Except for what is standard practice to be specified on the plans, the limitations described in C.8.2 through C.8.7 are suggested.

C.8.2 The lowest footing course shall be bedded directly against the sides of the excavation when the sides are self-supporting. Before the concrete is poured, adjacent dry soils shall be thoroughly moistened by sprinkling with water. Likewise, all loose material from cave-in, plus any soft rain-soaked soil, shall be removed from the bottom of the excavation.

C.8.3 The tops of all concrete slabs or mats shall be at least 6 in. above the final grade to be provided, and the tops of the pedestals and other foundations to support steelwork shall be at least 12 in. above the final grade or any mats or paving surfaces, if built adjacent.

C.8.4 The tops of foundations shall be large enough to project at least 3 in. outside of any steel baseplates of the superstructure.

C.8.5 The exposed surfaces, other than the tops of concrete pedestal and wall foundations, shall be smooth finished down to 6 in. below the proposed final grade. Any small holes left in the faces of pedestals, down to the first footing top, shall be troweled over with 1:3 mortar as soon as possible after forms have been removed.

C.8.6 Under column-type superstructures, base plates shall be provided, and allowance shall be made for 1-in. minimum grout.

C.8.7 Concrete ring walls or slab foundations for flat-bottom tanks, where the foundations specified are nominally true to the horizontal plane, shall be level within $\pm 1/8$ in. in any 30 ft of circumference and within $\pm 1/4$ in. in the total circumference measured from the average elevation.

C.9 Anchorage

C.9.1 Anchor bolts or straps and reinforcing steel for foundations may be supplied by the contractor or purchaser, as specified in the contract.

C.10 Backfill and Grading

All backfill around and over foundations shall be carefully deposited and rammed where it is next to concrete. No water

streams shall be used to compact the backfill, except where no clay is present and quick drainage is assured by the general contours. Bulldozers, scrapers, and crane-bucket discharge may be used if they are kept completely clear of the pedestals and walls.

If special adverse conditions are met, a foundation engineer shall be consulted regarding compaction control.

Particular attention shall be given to surface regrading around the finished structure to permit efficient erection of the superstructure and to provide proper drainage that is consistent with the records of local weather conditions.

The finished grade under a flat-bottom tank shall be crowned from the periphery to the center. A slope of 1 in. in 10 ft is suggested as a minimum. This crown will partly compensate for slight settlement, which is likely to be greater at the center; it will also aid in draining and cleaning the tank.

C.11 Inspection During the Hydrostatic Test

As a final check on the adequacy of the foundations and subgrade, the purchaser shall take level readings with surveyor's instruments around the entire periphery of the tank before water is introduced into the tank for the hydrostatic test. The readings shall be continued at reasonable intervals during the entire filling operation and shall be plotted promptly in suitable form to indicate whether any undue or uneven settlement is occurring. The results of these observa-

tions shall be reported to the tank erector and the purchaser's engineering representative. If at any time any questionable amount or rate of settlement does occur, further filling of the tank shall be stopped until a decision is reached as to what, if any, corrective measures are needed. Reference points on a tank or its foundations for use in making such observations shall be selected with care to ensure that the readings accurately reflect settlement of the subgrade and are not affected by possible changes in the shape of the tank walls.

If a minor amount of settlement is observed during the course of the filling operation and still continues after a tank is filled to the highest level required in the hydrostatic test, the water level in the tank shall not be lowered until further settlement has substantially ceased or a decision is reached that it might be unsafe to hold the water at that level any longer.

In no event, however, shall the water test be used as a planned means of soil compaction.

C.12 References

1. *Standard for Welded Steel Elevated Tank, Standpipes, and Reservoirs of Water Storage*, AWS-AWWA D5.2.
2. "Oil Storage Tank Foundations," *Technical Bulletin*, Chicago Bridge and Iron Co., March 1951.
3. K. Terzaghi and R.B. Peck, *Soil Mechanics in Engineering Practice*, John Wiley and Sons, Inc., New York, 1948.

**For Committee
Use Only**

APPENDIX D—SUGGESTED PRACTICE REGARDING SUPPORTING STRUCTURES

D.1 General

When a tank is supported on columns, a supporting ring or skirt, brackets, or comparable members, it will have concentrated loads imposed on its walls in the region where the supports are attached. When tanks of certain shapes are subject to internal pressure, secondary stresses may exist in the wall adjacent to the attachment of such supports that are lower than when the tank is filled with liquid before any pressure is imposed other than that caused by the static head. Methods for calculating the forces involved are not given in this standard because they involve so many variables that depend on the size, shape, and weight of the tank; the temperature of service; the internal pressure; the arrangement of the supporting structure; and the piping attached to the tank as installed.

D.2 Details of Supporting Structures

D.2.1 The details of supports shall conform to good structural practice, bearing in mind the considerations described in D.2.2 through D.2.5 (see 5.13 and the *Manual of Steel Construction*).

D.2.2 All supports shall be designed to prevent excessive localized stresses by temperature changes in the tank or deformations produced by variations in the pressure and liq-

uid-level conditions within the tank. Any arrangement of the structure that does not permit a reasonably free expansion and contraction of the tank walls will tend to weaken the tank.

D.2.3 External stays and ring girders or certain internal framing may exert a stiffening effect on the tank wall where exterior supporting members of the tank are to be attached. This stiffening effect may be beneficial or harmful, depending on the operating temperature and the location of the stiffening members.

D.2.4 In many cases it is preferable to use details that permit continuous welds which extend completely around the periphery of the attachment and avoid intermittent or dead-end welds at which there may be local stress concentration. A thicker wall plate at the support may serve to reduce secondary stresses, and if desired, a complete ring of thicker wall plates may be installed.

D.2.5 When forces acting on a tank wall at the attachment areas for supports of any kind can produce high bending stresses, and thicker wall plates do not seem appropriate, an oval or circular reinforcing plate may be used. The attachment of such reinforcing plates shall be designed to minimize flexing of the plate under forces normal to the surface of the tank wall.

**For Committee
Use Only**

APPENDIX E—SUGGESTED PRACTICE REGARDING ATTACHED STRUCTURES (INTERNAL AND EXTERNAL)

E.1 General

Some tanks constructed according to the rules of this standard may have internal structural bracing. Should these or their attachments fail, severe damage to the tank would result. The designer shall keep this possible hazard in mind and shall design such members and their attachments with sufficient strength and due allowance for corrosion.

E.2 Cautionary Suggestions

E.2.1 Cautionary suggestions, which shall be considered in the design of internal and external structures, are described in E.2.2 through E.2.5.

E.2.2 Where the structures are connected to the tank wall, details shall be provided that will prevent excessive localized tensile stress outward from the wall face because of the connection.

E.2.3 If platforms or stairways have separate supports, they shall preferably rest on top of the supports instead of hanging by bolts or rods.

E.2.4 If corrosion is expected, additional metal shall be provided. The corrosion allowance does not have to be the same as in the tank wall if the supports and structures can be readily and economically replaced without replacing the entire tank.

E.2.5 Corrosion-resistant metals may be used in the fabrication of the structural supports, but whenever the supports are attached by welding, the parts joined shall be weldable. These welds shall not introduce any objectionable conditions at or near the attachment, including hard or brittle zones, or both, or differences in electrical potential that might result in electrolytic corrosion.

**For Committee
Use Only**

APPENDIX F—EXAMPLES ILLUSTRATING APPLICATION OF RULES TO VARIOUS DESIGN PROBLEMS

F.1 Determination of Allowable Stress Values for Biaxial Tension and Compression

F.1.1 EXAMPLE 1

F.1.1.1 Given Conditions

In this example, an area of tank wall is constructed of ASTM A 131, Grade B, steel plate that is $\frac{3}{4}$ in. thick and has fully radiographed, double-welded butt joints. The wall is subject to tension in a latitudinal direction and to compression in a meridional direction. The values of R_1 and R_2 at the point under consideration are 60 in. and 315 in., respectively. A corrosion allowance of $\frac{1}{16}$ in. is required. The computed (meridional) compressive stress, s_{cc} , in the net thickness after deduction of the corrosion allowance is 3400 lbf/in.².

F.1.1.2 Problem

The problem in this example is to find the maximum allowable (latitudinal) tensile stress value for the given conditions, in conformance with the provisions of 5.5.3.3.

F.1.1.3 Solution

Since the compressive stress is meridional, the governing value of R in this situation is R_2 , or 315 in. Then,

$$\frac{t-c}{R} = \frac{0.75 - 0.0625}{315} = 0.00218$$

Figure 5-1 shall be entered in the text at a value of $(t-c)/R = 0.00218$. The ordinate shall be proceeded along vertically from this point to its intersection with the horizontal line for $s_c = 3400$ lbf/in.², and the value of N should be read at this intersection. In the case under consideration, $N = 0.867$. As determined from Table 5-1, the maximum allowable tensile stress value, S_{ts} , for ASTM A 131, Grade B, Steel plate in simple tension is 16,000 lbf/in.². Therefore, the maximum allowable tensile stress, s_{ta} , for the conditions cited in this example is as follows:

$$\begin{aligned} s_{ta} &= NS_{ts} \\ &= (0.867)(16,000) \\ &= 13,870 \text{ lbf/in.}^2 \end{aligned}$$

An efficiency factor need not be applied to this value because E for fully radiographed, double-welded butt joints exceeds the value of N as determined in the foregoing procedure. However, if the joints were spot radiographed—not fully radiographed—butt joints, E would have a value of only 85%.

In this case, the net allowable tensile stress, ES_{ts} , would be only $0.85 \times 16,000 = 13,600$ lbf/in.² determined from Figure 5-1, would govern.

Alternatively, s_{ta} could be determined by entering the computed value of M in Figure F-1 and obtaining the allowable coexistent value of N . For this particular example, the value of S_{cs} would be 15,000 lbf/in.². Hence,

$$M = \frac{S_{cc}}{S_{cs}} = \frac{3,400}{15,000} = 0.227$$

Note: An initial check shall be made to assure that the actual compressive stress, S_{cc} , equaling 3400 lbf/in.² does not exceed 1,800,000 $[(t-c)/R]$, which is calculated as follows: $1,800,000 \times 0.00218 = 3920$ lbf/in.².

Entering this value of M in Figure F-1 obtains the value $N = 0.867$. Therefore,

$$\begin{aligned} S_{ta} &= NS_{ts} \\ &= (0.867)(16,000) \\ &= 13,870 \text{ lbf/in.}^2 \end{aligned}$$

F.1.2 EXAMPLE 2

F.1.2.1 Given Conditions

In this example, the area of tank wall used is of the same construction, material, and geometry as that described in F.1.1.1 except that the thickness of the plate is $\frac{9}{16}$ in. The wall is stressed in the same manner as is described in F.1.1.1. A corrosion allowance of $\frac{1}{16}$ in. is required. The computed (meridional) compressive stress, s_{cc} , in the net thickness after deduction of the corrosion allowance is 4600 lbf/in.².

F.1.2.2 Problem

The problem in this example is to find the maximum allowable (latitudinal) tensile stress value for the given conditions, in conformance with the provisions of 5.5.3.3.

F.1.2.3 Solution

Since the compressive stress is meridional, the governing value of R in this situation is R_2 , or 315 in. Then,

$$\frac{t-c}{R} = \frac{0.5625 - 0.0625}{315} = 0.00158$$

Figure 5-1 shall be entered in the text at a value of $(t-c)/R = 0.00158$. The ordinate shall be proceeded along vertically from this point, noting that this line intersects the line with

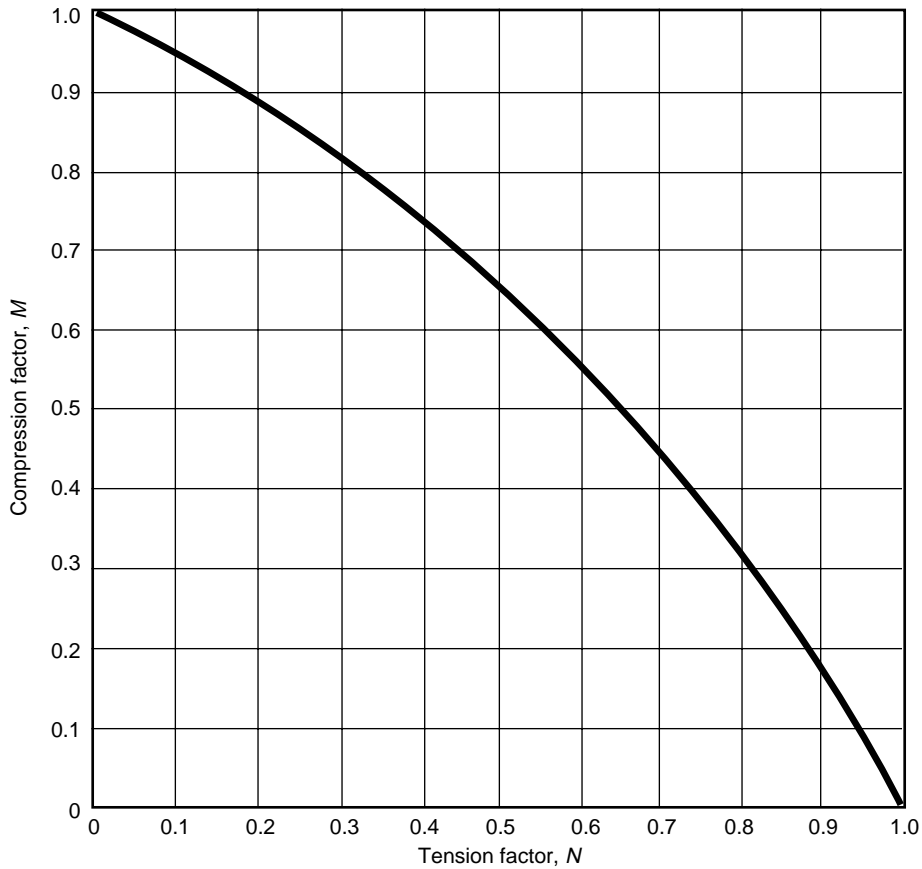

$$N^2 + MN + M^2 = 1$$

or

$$(s_t/S_{ts})^2 + (s_c/S_{ts})(s_c/S_{ts}) + (s_c/S_{ts})^2 = 1$$

Where

- N = (s_c/S_{ts}) .
- s_t = tensile stress, in pounds per square inch, at the point under consideration.
- S_{ts} = maximum allowable stress for simple tension, in pounds per square inch, as given in Table 5-1.
- M = (s_c/S_{cs}) .
- s_c = compressive stress, in pounds per square inch, at the point under consideration.
- S_{cs} = maximum allowable longitudinal compressive stress, in pounds per square inch, for a cylindrical wall acted upon by an axial load with neither a tensile nor a compressive force acting concurrently in a circumferential direction.

Figure F-1—Reduction of Design Stresses Required to Allow for Biaxial Stress of the Opposite Sign

the value $s_c = 4600 \text{ lbf/in.}^2$ on the chart to the left of line 0-A and that an extrapolation of the N curves would be required to determine the value of N . Since such an extension or extrapolation of the N curves is not permissible, no coexistent tensile stress is permissible under the conditions cited in this example. In fact, the compressive stress of 4600 lbf/in.^2 greatly exceeds the allowable stress, S_{cs} , of 2840 lbf/in.^2 for simple compression for the thickness-to-radius ratio involved. Consequently, either the thickness must be increased or the shape of the wall must be changed.

F.1.3 EXAMPLE 3

F.1.3.1 Given Conditions

In this example, an area of tank wall is constructed of ASTM A 285, Grade C, steel plate that is $5/8$ -in. thick and has spot-radiographed, double-welded butt joints. The wall is subject to tension in a meridional direction and to compression in a latitudinal direction. The values of R_1 and R_2 at the point under consideration are 75 in. and 300 in. respectively. A corrosion allowance of $1/16$ in. is required. The computed

(meridional) tensile stress, s_{tc} , in the net thickness after deduction of the corrosion allowance is 6000 lbf/in.².

F.1.3.2 Problem

The problem in this example is to find the maximum allowable (latitudinal) compressive stress value for the given conditions, in conformance with the provisions of 5.5.4.5.

F.1.3.3 Solution

As determined from Table 5-1, the maximum allowable tensile stress value, S_{ts} , for ASTM A 285, Grade C, steel plate in simple tension is 16,500 lbf/in.². Since the compressive stress is latitudinal, the governing value of R in this situation is R_1 , or 75 in. Then,

$$\frac{t-c}{R} = \frac{0.626-0.0625}{75} = 0.0075$$

The value $N = s_{tc}/S_{ts} = 6000/16,500 = 0.364$ shall be computed. The $(t-c)/R$ value of 0.0075 in Figure 5-1 shall be entered in the text, and the ordinate shall be proceeded along vertically at this value until it intersects with an N curve that represents the value $N = 0.364$; proceeding horizontally from this point to the left-side ordinate scale, the value $s_c = 11,500$ lbf/in.² should be read. In this case, the value represents the allowable compressive stress, s_{ca} .

Alternatively, s_{ca} could be determined by entering the computed value $N = 0.364$ in Figure F-1 and obtaining the corresponding allowable value $M = 0.767$. The allowable compressive stress, s_{ca} , could be calculated by substituting this value of M in the equation $s_{ca} = 15,000M$. Thus, $s_{ca} = 15,000 \times 0.767 = 11,500$ lbf/in.².

Note: A check shall be made to ensure that the compressive stress does not exceed 1,800,000 $[(t-c)/R]$ which is calculated as follows: $1,800,000 \times 0.0075 = 13,500$ lbf/in.².

F.1.4 EXAMPLE 4

F.1.4.1 Given Conditions

In this example, the area of tank wall used is of the same construction, material, and geometry as that described in F.1.3.1 except that the thickness of the plate is $3/8$ in. The wall is stressed in the same manner as is described in F.1.3.1. A corrosion allowance of $1/16$ in. is required. The computed (meridional) tensile stress, s_{tc} , in the net thickness after deduction of the corrosion allowance is 8000 lbf/in.².

F.1.4.2 Problem

The problem in this example is to find the maximum allowable (latitudinal) compressive stress value for the given conditions, in conformance with the provisions of 5.5.4.5.

F.1.4.3 Solution

As determined from Table 5-1, the maximum allowable tensile stress value, S_{ts} , for ASTM A 285, Grade C, steel plate in simple tension is 16,500 lbf/in.². Since the compressive stress is latitudinal, the governing value of R in this situation is R_1 , or 75 in. Then,

$$\frac{t-c}{R} = \frac{0.375-0.0625}{75} = 0.00415$$

The value $N = s_{tc}/S_{ts} = 8000/16,500 = 0.485$ shall be computed. The $(t-c)/R$ value of 0.00415 shall be entered at the bottom of Figure 5-1 in the text. The ordinate shall be proceeded along vertically at this value, noting that the N curves would have to be extrapolated to the left of line 0-A to intersect with the vertical line that represents the $(t-c)/R$ value of 0.00415. Since no extrapolation is permitted to the left of line 0-A, the intersection of this vertical line with line 0-A yields a value on the left ordinate scale of 7500 lbf/in.², which represents the maximum allowable compressive stress, s_{ca} , for this particular value of $(t-c)/R$. A higher value of tensile stress is permissible, since the allowable coexistent value of N equals 0.65. Thus, in this particular example, the allowable compressive stress is governed by the $(t-c)/R$ value rather than by the coexistent tensile stress.

F.2 Determination of Minimum Required Thicknesses for Walls Subject to Biaxial Tension and Compression

F.2.1 EXAMPLE 1

F.2.1.1 Given Conditions

In this example, an elemental area of tank wall used is constructed of ASTM A 442, Grade 55, steel plate subjected to a meridional unit force, T_1 , of 4000 lbf/in.² tension and a latitudinal unit force, T_2 , of 5060 lbf/in.² compression. The meridional radius of curvature, R_1 , is 75 in., and the length of the normal from the surface to the axis of revolution, R_2 , is 300 in. The joints in the wall are of double-welded butt-joint construction with a tensile efficiency of 85%. A corrosion allowance of $1/16$ in. is required.

F.2.1.2 Problem

The problem in this example is to graphically find the minimum thickness of tank wall required for the given conditions (see 5.10.3.3).

F.2.1.3 Solution

As determined from Table 5-1, the maximum allowable tensile stress value, S_{ts} , for ASTM A 442, Grade 55, steel plate in simple tension is 16,500 lbf/in.². Since the compressive stress is latitudinal, the governing value of R in this situation is R_1 , or 75 in.

Table F-1—Computed Values of $(t - c)R$, s_c , s_t , and N for the Assumed Thicknesses:
Example 1 (see F2.1.3)

Assumed Thickness, t (in.)	$\frac{t-c}{R_1}$	$s_t = \frac{T_2}{t-c}$	$s_t = \frac{T_1}{t-c}$	$N = \frac{s_t}{S_{ts}}$
1	0.0125	5.400	4270	0.258
$3/4$	0.0092	7.360	5820	0.353
$5/8$	0.0075	9.000	7110	0.431
$9/16$	0.0066	10.120	8000	0.485
$1/2$	0.0058	11.570	9140	0.554

A series of four or five different plate thicknesses should be assumed, covering the range in which the required thickness will probably be found. The values of $(t - c)R$, s_c , s_t , and N shall be computed and tabulated for each of the assumed thicknesses, as shown in Table F-1.

The values of s_c shall be plotted on Figure F-2³⁹ at the respective values of $(t - c)R$ associated with them, and a smooth curve U-U shall be drawn that connects the points located in this manner. The N and $(t - c)R$ points shall also be plotted, and a smooth curve V-V shall be drawn to connect them.

The intersection of these two curves represents the minimum $(t - c)R$ value that will satisfy both the compressive stress and tensile stress limitations involved in this example. At this point s_c (which is equivalent to s_{ca} in this problem) equals 10,000 lbf/in.²; N equals approximately 0.480; and $(t - c)R$ equals 0.0067. The efficiency, E , for the type of joints involved is 85%. Since this is greater than N , the value of s_t (or s_{ta}) for the conditions under consideration is equal to the value of NS_{ts} , or $0.480 \times 16,500 = 7920$ lbf/in.².

Therefore,

$$t = \frac{T_1}{S_{ta}} + c = \frac{4000}{7920} + 0.063 = 0.505 + 0.063$$

$$= 0.568 \text{ in.}$$

or

$$t = \frac{T_2}{S_{ca}} + c = \frac{5060}{10,000} + 0.063 = 0.506 + 0.063$$

$$= 0.569 \text{ in.}$$

or

$$t = \left(\frac{t-c}{R} \right) R_1 + c = (0.0067)(75) + 0.063$$

$$= 0.503 + 0.063 + 0.566 \text{ in.}$$

³⁹Figure F-3 is a copy of this chart without the illustrative example lines. It may be reproduced by the designer for use in graphical solutions.

F.2.2 EXAMPLE 2

F.2.2.1 Given Conditions

In this example, an elemental area of tank wall is constructed of ASTM A 516, Grade 55, steel plate subjected to a meridional unit force, T_1 , of 2620 lbf/in. tension and a latitudinal unit force, T_2 , of 2880 lbf/in. compression. The meridional radius of curvature, R_1 , is 132 in., and the length of the normal from the surface to the axis of revolution, R_2 , is 409 in. The joints in the wall are spot-radiographed, double-welded butt joints, and no corrosion allowance is required.

F.2.2.2 Problem

The problem in this example is to graphically find the minimum thickness of tank wall required for the given conditions (see 5.10.3.3).

F.2.2.3 Solution

As determined from Table 5-1, the maximum, allowable tensile stress value, S_{ts} , for ASTM A 516, Grade 55, steel plate in simple tension is 16,500 lbf/in.². Since the compressive stress is latitudinal, the governing value of R for this situation is R_1 , or 132 in.

A series of four or five different plate thicknesses shall be assumed, covering the range in which the required thickness will probably be found. The values of $(t - c)R$, s_c , s_t , and N shall be computed and tabulated for each assumed thickness, as shown in Table F-2.

The value of s_c shall be plotted on Figure F-2 at the respective values of $(t - c)R$ associated with them, and a smooth curve W-W shall be drawn between the points located in this manner. The N and $(t - c)R$ points shall also be plotted, and a smooth curve X-X shall be drawn to connect them.

These two curves intersect each other on the left-hand side of line A-A. The use of values represented by points in this area is prohibited. All values of N in the vicinity of these two

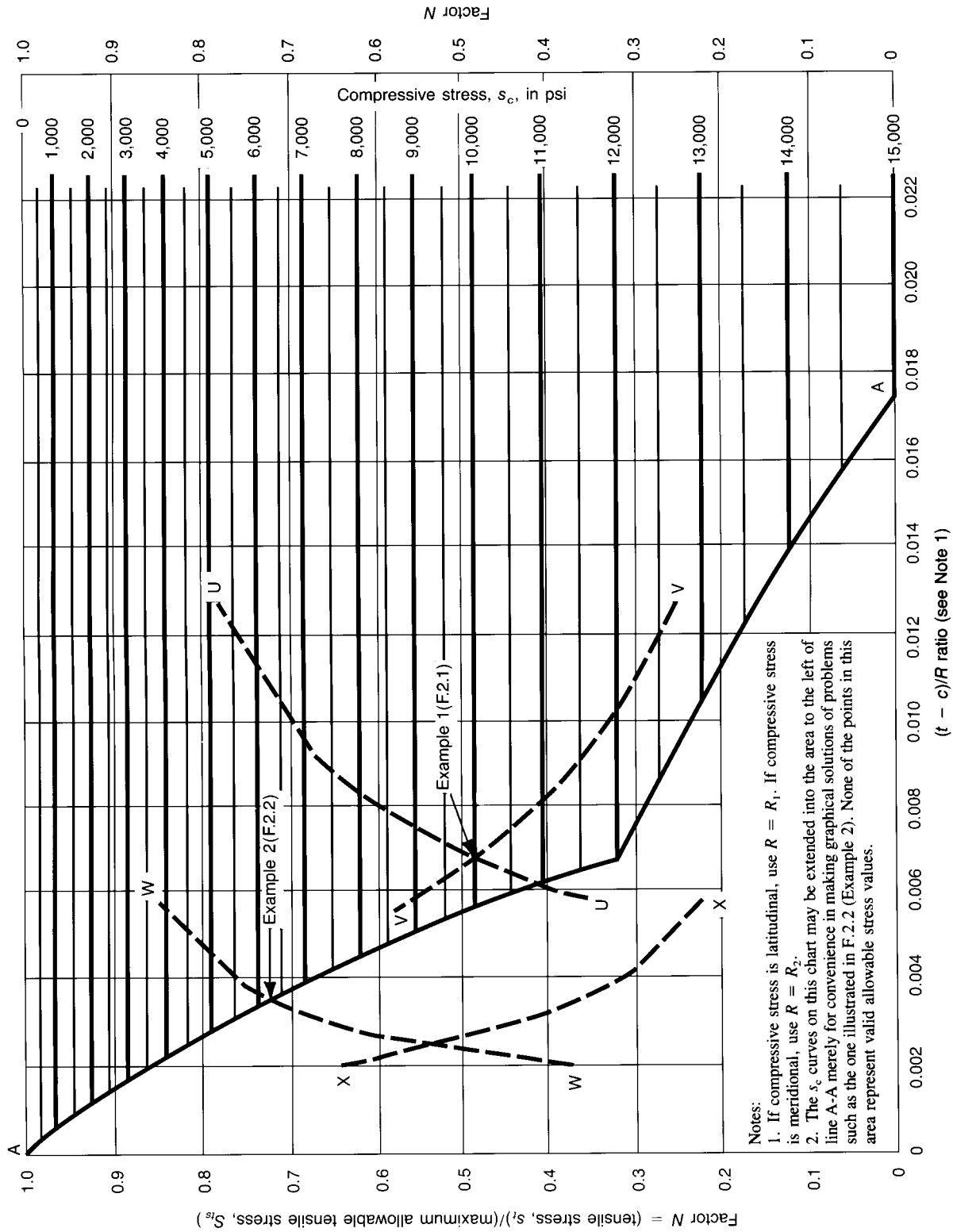
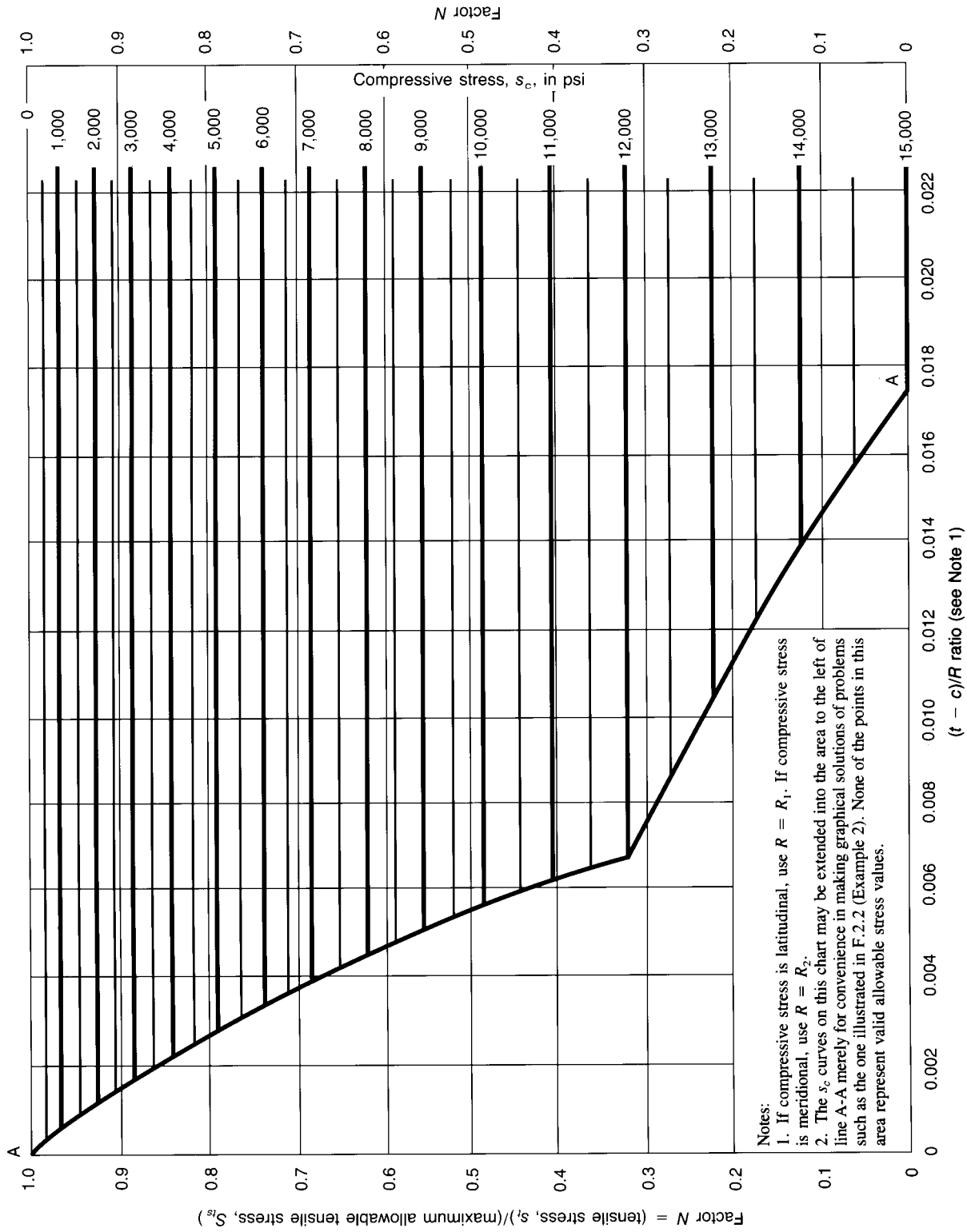

Figure F-2—Examples Illustrating the Use of a Biaxial Stress Chart for Combined Tension and Compression, 30,000–38,000 Pounds per Square Inch Yield Strength Steels



Notes:
 1. If compressive stress is latitudinal, use $R = R_1$. If compressive stress is meridional, use $R = R_2$.
 2. The s_c curves on this chart may be extended into the area to the left of line A-A merely for convenience in making graphical solutions of problems such as the one illustrated in F.2.2 (Example 2). None of the points in this area represent valid allowable stress values.

Figure F-3—Form for Use in Graphical Solutions of Problems Involving Biaxial Tension and Compression, 30,000–38,000 Pounds per Square Inch Yield Strength Steels

Table F-2—Computed Values of $(t - c)R$, s_c , s_t , and N for the Assumed Thicknesses:
Example 2 (see F2.2.3)

Assumed Thickness, t (in.)	$\frac{t-c}{R_1}$	$s_t = \frac{T_2}{t-c}$	$s_t = \frac{T_1}{t-c}$	$N = \frac{s_t}{S_{ts}}$
$3/4$	0.05680	3.840	3.490	0.212
$1/2$	0.00378	5.760	5.240	0.318
$3/8$	0.00284	7.680	6.990	0.424
$5/16$	0.00237	9.200	8.380	0.507
$1/4$	0.00189	11.520	10.480	0.635

curves are well below the efficiency, E , of the type of joints involved; thus, the allowable compressive stress is obviously the critical factor in this problem. A point must be found where the computed compressive stress, represented by points on the curve W-W, does not exceed the allowable compressive stress. This will be at the intersection of curve W-W and line A-A, where $s_c = 6300$. This value is the allowable compressive stress, s_{ca} , for the conditions given in this example. Therefore,

$$t = \frac{T_2}{S_{ca}} + c = \frac{2880}{6300} + 0 = 0.457 \text{ in.}$$

This value is the minimum required thickness. The computed tensile stress for this thickness is only $2620 \div 0.457 = 5730 \text{ lbf/in.}^2$, whereas the values of N at the intersection of curve W-W and line A-A indicates that a tensile stress of $16,500 \times 0.72 = 11,880 \text{ lbf/in.}^2$ would have been permissible. Thus, the plate at this level will not be stressed to its fullest potential for tensile loading.

F.3 Determination of Minimum Required Thicknesses for Walls Subject to Biaxial Compression From Meridional and Latitudinal Unit Forces

F.3.1 GIVEN CONDITIONS

In this example, the tank used to store liquid has a dome-shaped, self-supporting roof with varying values for R_1 and R_2 . The size and vacuum settings of the vacuum-relieving devices are such that the partial vacuum developed in the tank at the maximum air inflow is 0.40 lbf/in.^2 gauge (see 5.3.1). The roof is covered with insulation weighing 2 lb/ft^2 . The design requirements include a live snow load of 25 lb/ft^2 on the horizontal projection of the surface of the roof, which has a slope of 30° or less with the horizontal and a $1/16$ in. corrosion allowance.

F.3.2 PROBLEM

The problem in this example is to find the required plate thicknesses for the vacuum and external loading (a) at the center of the roof, where $R_1 = R_2 = 1200$ in. and (b) at a radial distance of 12.5 ft from the center of the roof, where $R_1 = 1117$ in. and $R_2 = 1172$ in.

F.3.3 SOLUTION

F.3.3.1 General

Figure F-4 is a free-body sketch of the roof above the plane of the level under consideration. Specific values for the variables used in this figure are as follows (see Figure 5-4 for typical free-body diagrams and 5.10.1 for definitions of the other variables):

- $P = -0.40 \text{ lbf/in.}^2$ gauge, a negative value because of the internal vacuum,
- $W =$ sum of the weights of the steel plate, insulation load, and snow load. W must be given the same sign as P in this case because it acts in the same direction as the pressure on the plane of the level under consideration; therefore, W is negative (see 5.10.1 of the definition of W),
- $F =$ zero because no ties, braces, supports, or other similar members are cut by the plane of the level under consideration.

F.3.3.2 Finding the Thickness at the Center of the Roof

As a trial, a plate thickness of $27/32$ in. (0.844 in.) at the center of the roof is assumed, including a $1/16$ in. corrosion allowance, which is equivalent to a unit weight of 34.4 lb/ft^2 .

On a 1 in.^2 area at the corner of the roof,

$$\frac{W}{A} = \frac{2 + 25 + 34.4}{144} = 0.426 \text{ lb/in.}^2$$

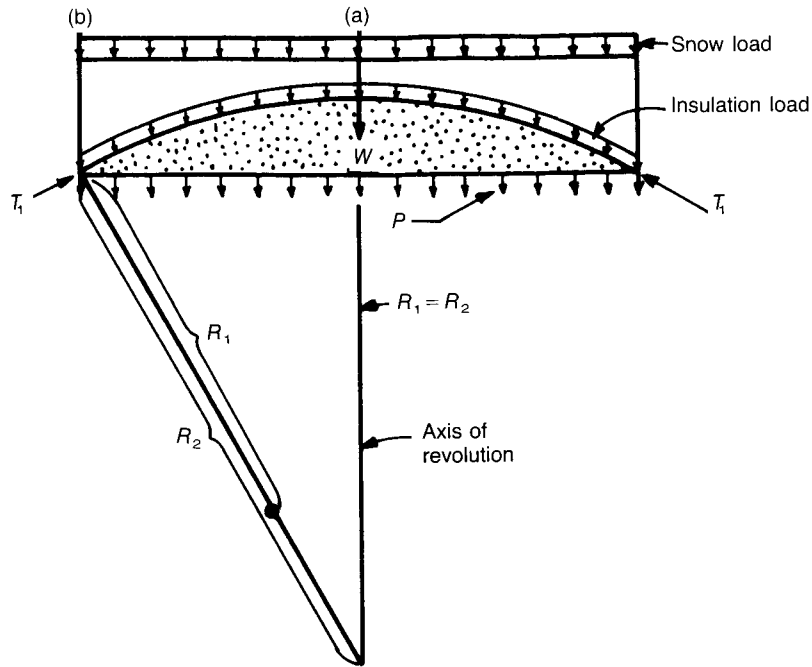

Figure F-4—Free-Body Sketch (See F.3)

From 5.10.2.5, using Equations 4 and 5,

$$T_1 = \frac{1200}{2} [(-0.40 - 0.426)]$$

$$= -495.6 \text{ lbf/in.}$$

$$T_2 = 1200 (-0.40 - 0.426) - (-495.6)$$

$$= -495.6 \text{ lbf/in.}$$

From 5.10.3.4, using Equation 17,

$$t = \frac{495.6}{s_{ca}}$$

where

$$s_{ca} = 1,000,000[(t - c)/R].$$

Substituting $s_{ca} = 1,000,000 [(t - c)/R]$ for s_{ca} in Equation 17 yields the following:

$$(t - c)^2 = \frac{495.6R}{1,000,000}$$

$$t = \frac{\sqrt{(495.6)(1200)}}{1000} + 0.063 = 0.834 \text{ in.}$$

This value is slightly less than the assumed thickness.

A more exact solution could be worked out using a second thickness whose value is between the first assumption and the calculated value.

F.3.3.3 Finding the Thickness at a Radial Distance of 12.5 ft

As a trial, a plate thickness of $13/16$ in. (0.813 in.) at a radial distance of 12.5 ft is assumed, including a $1/16$ in. corrosion allowance, which is equivalent to a unit weight of 33.2 lbs/ft².

$$W = (\pi)(12.5)^2(2 + 25 + 33.2) = 29,550 \text{ lbs}$$

$$\sin \theta = \frac{(12.5)(12)}{1172} = 0.1280$$

$$\cos \theta = 0.9918$$

$$\theta = 7.35^\circ$$

Note: Technically, the surface area of the roof above the level under consideration shall be used in the preceding calculation of W ; however, from a practical standpoint, in this example the difference between the actual surface area and the area of the horizontal plane bounded by the free-body is relatively small and can be ignored in the calculation of W . The designer is cautioned that in many cases a more exact calculation of the roof area and weight will be necessary.

Normal-to-the-surface components of the metal, insulation, and snow loads are given per unit area of plate surface as follows:

a. For metal, $33.2 \text{ lb/ft}^2 \div 144$;

$$\cos \theta = 0.229 \text{ lb/in.}$$

b. For insulation, $2.0 \text{ lb/ft}^2 \div 144$;

$$\cos \theta = 0.014 \text{ lb/in.}^2$$

c. For snow, $25.0 \text{ lb/ft}^2 \div 144$;

$$\cos 2 \theta = 0.171 \text{ lb/in.}^2.$$

The total of the normal components of load is 0.414 lbf/in.^2 .

From 5.10.2.1, using Equations 1 and 2 with the foregoing normal components of load,

$$T_1 = \frac{1172}{2} \left[-0.40 + \frac{-29,550}{(\pi)(12.5)^2(144)} \right]$$

$$= -479 \text{ lbf/in.}$$

$$T_2 = 1172 \left[(-0.40 - 0.414) - \left(\frac{-479}{1117} \right) \right]$$

$$= -451 \text{ lbf/in.}$$

From 5.10.3.5, using Equation 18 and 19 where $T' = T_1$, $T'' = T_2$, $R' = R_2$, and $R'' = R_1$:

In this first step, according to Equation 18,

$$t = \sqrt{\frac{479 + (0.8)(451)(1172)}{1342}} + 0.063 \text{ in.}$$

$$= 0.802 \text{ in.}$$

According to Equation 19,

$$t = \frac{\sqrt{(451)(1117)}}{1000} + 0.063 \text{ in.} = 0.773 \text{ in.}$$

In the second step, for the thickness determined by Equation 18,

$$\frac{t-c}{R'} = \frac{0.802 - 0.063}{1172} = 0.000631$$

For the thickness determined by Equation 19,

$$\frac{t-c}{R''} = \frac{0.773 - 0.063}{1117} = 0.000636$$

Since both $(t-c)/R$ ratios are less than 0.0067, the larger of the thicknesses calculated in the first step is the required thickness if it is consistent with the assumed thickness. Further calculations using Steps 3–6 are unnecessary.

The calculated thickness of 0.802 in. is slightly smaller than the assumed thickness of $13/16$ in. (0.813 in.) and is thus consistent from a practical standpoint with the assumed roof loading. A recalculation using a new assumed thickness shall be made whenever the calculated thickness is appreciably greater than the thickness assumed for the determination of the total roof load.

F.4 Design of Compression-Ring Regions

F.4.1 EXAMPLE 1

F.4.1.1 Given Conditions

In this example, a cylindrical tank 30 ft in diameter is designed for an internal pressure of 5 lbf/in.^2 gauge in the vapor space. The plate material is ASTM A 131, Grade A, for thicknesses of $1/2$ in. and less. The top course of the butt-welded cylindrical sidewall is $1/4$ in. thick, including a $1/16$ in. corrosion allowance. The roof is a butt-welded spherical dome with an internal radius of 30 ft and a thickness of $1/4$ in., including a $1/16$ in. corrosion allowance. The maximum design liquid level is 6 in. below the plane of the juncture of the roof and sidewall.

F.4.1.2 Problem

The problem in this example is to design the compression-ring region at the juncture of the roof and cylindrical sidewall.

F.4.1.3 Solution

From Figure 5-5, $\cos = 15/30 = 0.5$. Hence, $\theta = 60$ degrees and $\sin \theta = 0.866$.

Equations 7 and 13 in 5.10.2.5 govern the design of the roof and sidewall because the term $(W + F) \div A_r$ is negligible compared with P_g .

$$T_1 = T_2 = (0.5)(5)(360) = 900 \text{ lbf/in.}$$

$$T_{2s} = (5)(180) = 900 \text{ lbf/in.}$$

From 5.12.4.2 and 5.12.4.3, using Equations 24–27,

$$w_h = 0.6\sqrt{360(0.25 - 0.0625)} = 4.9 \text{ in.}$$

$$w_c = 0.6\sqrt{180(0.25 - 0.0625)} = 3.5 \text{ in.}$$

$$Q = (900)(4.9) + (900)(3.5) - (900)(180)(0.866) \\ = -133,000 \text{ lbs}$$

$$A_c = 133,000/15,000 = 8.86 \text{ in.}^2$$

The area of participating width of the roof plate is determined as follows:

$$4.9(0.25 - 0.0625) = 0.92 \text{ in.}^2$$

The area of participating width of the sidewall plate is determined as follows:

$$3.5(0.25 - 0.0625) = 0.66 \text{ in.}^2$$

The total area provided is 1.58 in.².

From 5.12.5.3, the required additional area is 8.86 – 1.58 = 7.28 in.².

From 5.12.5.1, the required horizontal projection of the effective compression-ring region is $0.015R_c = 0.015 \times 180 = 2.7$ in.

The horizontal projection of the roof plate within the compression-ring region is $4.9 \times 0.866 = 4.25$ in., which fulfills the requirement of 5.12.5.1.

The required area and horizontal projection can be provided by any of the standard angles listed in Table F-3.

Any of these angles may be used in accordance with the details of Figure 5-6, detail a or b, but if details c, h, or i in Figure 5-6 were intended, the net area of the angle must be calculated by deducting the area expected to be lost by corrosion from that part of the angle surface that is exposed to the interior of the tank. The net area of the angle must equal or exceed the calculated required additional area. The area can also be provided with a bar or channel section as illustrated in Figure 5-6, details d–g, with proper consideration given to the $0.015R_c$ minimum width, the $16t$ maximum width, and the net area after deduction of the corroded thickness.

No bracing is required for any of the previously listed angles because in no case does the width of any leg exceed 16 times its thickness (see 5.12.5.8).

The centroid of the compression region shall be checked to meet the conditions of 5.12.5.2.

F.4.2 EXAMPLE 2

F.4.2.1 Given Conditions

In this example, a cylindrical tank 75 ft in diameter is designed for an internal pressure of 0.5 lbf/in.² gauge in the vapor space. The plate material is ASTM A 131, Grade B, steel for thicknesses of 1/2 in. and less.

Table F-3—Cross-Sectional Area of Standard Angles: Example 1 (See F.4.1.3)

Angle Dimensions (in.)	Cross-Sectional Area (in. ²)
6 × 6 × 3/4	8.44
5 × 5 × 7/8	7.98
9 × 4 × 5/8	7.73
8 × 6 × 9/16	7.56
8 × 4 × 3/4	8.44
7 × 4 × 3/4	7.69
6 × 4 × 7/8	7.98

The top course of the butt-welded cylindrical sidewall is 1/4 in. thick. The roof is a conical shape with a 2:12 slope and a 1/4 in. thickness with single full-fillet welded lap joints. The maximum design liquid level is 6 in. below the plane of juncture of the roof and sidewall.

F.4.2.2 Problem

The problem in this example is to design the compression-ring region at the juncture of the roof and cylindrical sidewall.

F.4.2.3 Solution

From Figure 5-5, $\tan \alpha = 12/2 = 6.0$. Hence, $\alpha = 80.54^\circ$, $\sin \alpha = 0.9864$, and $\cos \alpha = 0.1643$. $R_c = R_3 = 37.5$ ft = 450 in.

At the edge of the roof, $R_2 = 450/0.1643 = 2740$ in.

Because of the relatively low pressure, the weight of the roof plate is a practical factor. In view of the small difference between the conical area of the roof and the projected area on a horizontal plane, W can be calculated with sufficient accuracy by using the unit weight of 10.2 lbs/ft² for the 1/4-in. roof plate and the cross-sectional area of the tank at the roof-side-wall juncture. F is zero because no internal or external ties, braces, diaphragms, trusses, columns, skirts, or other structural supports are attached to the roof.

For practical purposes, in this example $(W + F)/A_t = 10.2/144$. W must be given a negative sign in this case because it acts in the direction opposite from P , and P is positive (see the definition of W in 5.10.1).

From 5.10.2.5, using Equations 8 and 9,

$$T_1 = \left[\frac{450}{(2)(0.1643)} \right] \left[(0.5) + \frac{-10.2}{144} \right] \\ = 588 \text{ lbf/in.}$$

$$T_2 = \frac{(0.5)(450)}{0.1643} = 1370 \text{ lbf/in.}$$

$$T_{2s} = (0.5)(450) = 225 \text{ lbf/in.}$$

From 5.12.4.2 and 5.12.4.3, using Equations 24-27,

$$w_h = 0.6\sqrt{(2740)(0.25)} = 15.7 \text{ in.}$$

$$w_c = 0.6\sqrt{(450)(0.25)} = 6.4 \text{ in.}$$

$$Q = (1370)(15.7) + (225)(6.4)$$

$$- (588)(450)(0.9864)$$

$$= 240,000 \text{ lb}$$

$$A_c = 240,000/15,000 = 16.0 \text{ in.}^2$$

Note: The width of lap-welded roof plate, w_h , must be used in calculating the force Q , but the lap-welded roof plates cannot be given credit for contributing to the area required for resisting the compressive force or providing a width of horizontal projection of the compression-ring region (see 5.12.2).

The area of the participating width of the roof plate (lap-welded) is 0.00 in.^2 .

The area of the participating width of the shell plate is $6.4 \times 0.25 = 1.6 \text{ in.}^2$.

The required additional area (see 5.12.5.3, Item a) is $16.0 - 1.6 = 14.4 \text{ in.}^2$.

The required horizontal projection of the effective compression-ring region (see 5.12.5.1) is $0.015R_c = 0.015 \times 450 = 6.75 \text{ in.}$

Because the lap-welded construction of the roof may not be used to satisfy the horizontal width requirement, the horizontal projection of the roof plate with the compression-ring region must be provided by the added member.

Angles may not be a practical method of providing the required additional area and horizontal projection. Bars or channels may be furnished as illustrated in Figure 5-6, details d-g, with proper consideration given to the $0.015R_c$ minimum width requirement and the requirements concerning the bracing of the compression ring, where applicable.

F.4.3 EXAMPLE 3

F.4.3.1 Given Conditions

In this example, a cylindrical tank 62 ft 6 in. in diameter is designed for an internal pressure of 4 lbf/in.² gauge in the vapor space. The plate material is ASTM A 131 steel with appropriate grades for different plate thicknesses in accordance with Table 4-1 for a design metal temperature less than 65°F but not less than 25°F. No corrosion allowance is

required for any portion of the tank. The top course of the butt-welded cylindrical sidewall is $\frac{1}{4}$ in. thick. The roof is a single lap-welded spherical dome with an internal radius of 50 ft and a thickness of $\frac{1}{4}$ in. The maximum design liquid level is 6 in. below the plane of the juncture of the roof and sidewall.

F.4.3.2 Problem

The problem in this example is to design the compression-ring region at the juncture of the roof and cylindrical sidewall.

F.4.3.3 Solution

From Figure 5-5, $\cos \alpha = 31.25/50 = 0.625$. Hence, $\alpha = 51.4$ degrees and $\sin \alpha = 0.781$.

Equations 7 and 13 in 5.10.2.5 govern the design of the roof and sidewall, since the term $(W + F)/A_t$ is negligible compared with P_g .

$$T_1 = T_2 = (1/2)(4)(600) = 1200 \text{ lbf/in.}$$

$$T_{2s} = (4)(375) = 1500 \text{ lbf/in.}$$

From 5.12.4.2 and 5.12.4.3, using Equations 24-27,

$$w_h = 0.6\sqrt{(600)(0.25)} = 7.34 \text{ in.}$$

$$w_c = 0.6\sqrt{(375)(0.25)} = 5.80 \text{ in.}$$

$$Q = (1200)(7.34) + (1500)(5.80)$$

$$- (1200)(375)(0.781)$$

$$= -334,000 \text{ lb}$$

$$A_c = 334,000/15,000 = 22.3 \text{ in.}^2$$

Note: The width of the lap-welded roof plate, w_h , must be used in calculating the force Q , but the lap-welded roof plates cannot be given credit for contributing to the area required for resisting the compressive force or providing a width of horizontal projection of the compression-ring region (see 5.12.2).

The area of the participating width of the roof plate (lap-welded) is 0.00 in.^2 . The area of the participating width of the sidewall plate is $5.80 \times 0.25 = 1.45 \text{ in.}^2$. The total area provided is 1.45 in.^2 .

From 5.12.5.3, the required additional area is $22.3 - 1.45 = 20.85 \text{ in.}^2$. Since this area cannot be provided by standard angles, a detail employing a bar, ring girder, or channel must be used.

A bar 1-in. thick should be assumed, as illustrated in Figure 5-6, detail e.

From 5.12.4.2 and 5.12.4.3, using Equations 24-27,

$$w_h = 0.6\sqrt{(600)(1)} = 14.7 \text{ in.}$$

$$w_c = 0.6\sqrt{(375)(0.25)} = 5.80 \text{ in.}$$

$$Q = (1200)(14.7) + (1500)(5.8)$$

$$- (1200)(375)(0.781)$$

$$= -325,160 \text{ lb}$$

$$A_c = 325,160/15,000 = 21.68 \text{ in.}^2$$

The area of the participating width of the compression ring is $14.7 \times 1 = 14.70 \text{ in.}^2$. The area of the participating width of the sidewall plate is $5.8 \times 0.25 = 1.45 \text{ in.}^2$. The total area provided is 16.15 in.^2 .

Since the required area, A_c , is larger than the total area provided, the area of the compression ring must be increased. This can be accomplished by extending the bar outside the sidewall.

The additional width required is computed as follows:

$$\frac{(21.68 - 15.15)}{1.00} = 5.53 \text{ in.}$$

The bar extension is less than $16t$ maximum for projecting parts of a compression ring that is not braced (see 5.12.5.8).

The total width of the compression bar is $14.7 + 5.53 = 20.23 \text{ in.}$

From 5.12.5.1, the required horizontal projection of the effective compression-ring region is $0.015R_c = 0.015 \times 375 = 5.62 \text{ in.}$

The horizontal projection of the compression ring is $14.7 \times 0.781 = 11.5 \text{ in.}$, which fulfills the requirement of 5.12.5.1.

The centroid of the compression region shall be checked to meet the conditions of 5.12.5.2.

F.5 Design of Reinforcement for Single Openings in Tank Walls

F.5.1 EXAMPLE 1

The 20 in. \times 29 in. obround manhole shown in Figure F-5 is located in solid plate in the sidewall of a cylindrical storage tank 45 ft in diameter in an area where the thickness of the wall plate, t_w , is $1/2 \text{ in.}$ No corrosion allowance is required. The total internal pressure, $P_1 + P_g$, at the horizontal centerline of the opening is 27.5 lbf/in.^2 gauge. The thickness of the wall plate, t , required by 5.10.3 for the latitudinal unit forces, T_2 , acting at this level is 0.485 in. The manhole neck is fabricated by welding from $3/8 \text{ in.}$ plate. The materials in the tank wall, the manhole neck, and the reinforcing pad conform to

ASTM A 516, Grade 60. The joints in the tank wall and the longitudinal joint or joints in the manhole neck are double-welded butt joints, spot radiographed in accordance with 7.16 and 7.17. The adequacy of the reinforcement and attachment welds shown in Figure F-5 shall be determined.

The net thickness required for a seamless tank wall at the horizontal centerline of the opening is calculated as follows:

$$t_r = (0.485)(0.85) = 0.412 \text{ in.}$$

The thickness required for the semicircular ends of the manhole neck and for the roundabout stresses in the flat portions of the neck for the pressure at the horizontal centerline of the opening is calculated as follows:

$$t_{rn} = \frac{(27.5)(10)}{(18,000)(0.85)} = 0.018 \text{ in.}$$

Note: A thickness of 0.17 in. is required in the flat portions of the neck for the stresses that are parallel to the axis of the manhole; these stresses result from the beam action of the elements calculated as simple beams supported by the tank wall and the manhole flange. A thickness of not less than $3/8 \text{ in.}$ must be provided in the entire neck to satisfy the provisions of 5.19.2, item b. Neither of these requirements affects the value of t_{rn} used for reinforcement.

To determine the length of the manhole neck within the limits of reinforcement, the smaller of the following calculated values shall be used:

$$(2.5)(0.5) = 1.25 \text{ in.}$$

$$(2.5)(0.375) + 0.5 = 1.438 \text{ in.}$$

The minimum size of the outer fillet weld permitted by Figure 5-8, panel k, is calculated as follows:

$$\frac{(0.5)(0.5)}{0.707} = 0.35 \text{ in.}$$

The minimum size of the inner fillet weld permitted by Figure 5-8, panel k, is calculated as follows:

$$\frac{(0.7)(0.375)}{0.707} = 0.37 \text{ in.}$$

Therefore, the weld sizes used meet the minimum requirements of Figure 5-8, panel k.

The area of reinforcement requirement at and between the vertical centerlines of the semicircular ends is calculated as follows:

$$A_r = (20)(0.485)(0.85) = 8.25 \text{ in.}^2$$

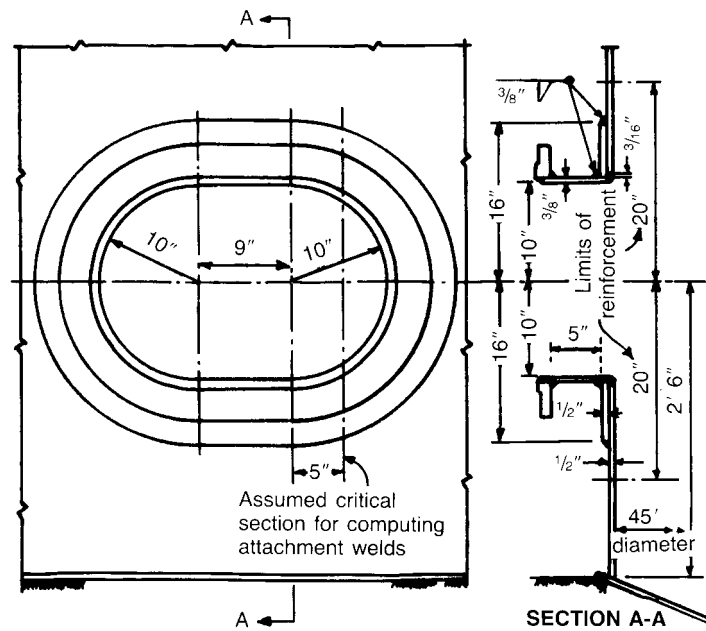

Figure F-5—Example of a Reinforced Opening (See F.5.1)

The areas of reinforcement provided are as follows:

- a. From excess thickness in the tank wall,

$$A_1 = 20 \times (0.5 - 0.412) = 1.76 \text{ in.}^2$$

- b. From excess thickness in the manhole neck,

$$A_2 = 2 \times 1.25 \times (0.375 - 0.018) = 0.89 \text{ in.}^2$$

- c. In fillet welds,

$$A_3 = 4 \times 0.5 \times (0.375)^2 = 0.28 \text{ in.}^2$$

- d. In the reinforcing pad,

$$A_4 = (32 - 20.75) \times 0.5 = 5.62 \text{ in.}^2$$

The total area of reinforcement provided is 8.55 in.², which is adequate.

The allowable unit stress values for the attachment elements are as follows:

- a. For the outer and inner fillet welds,

$$18,000 \times 0.60 = 10,800 \text{ lbf/in.}^2$$

- b. For shear across the groove weld,

$$18,000 \times 0.8 \times 0.875 \times 0.75 = 9450 \text{ lbf/in.}^2$$

- c. For tension across the groove weld,

$$18,000 \times 0.875 \times 0.75 = 11,810 \text{ lbf/in.}^2$$

- d. For shear in the manhole neck,

$$18,000 \times 0.8 \times 0.875 = 12,600 \text{ lbf/in.}^2$$

The strengths of the attachment elements beyond the critical section shown in Figure F-5 are as follows:

- a. *Element 1.* For the outer fillet weld,

$$\left[\left(\frac{\pi}{2} \right) (32) - (2)(5) \right] (0.375)(0.707)(10,800) = 115,300 \text{ lb}$$

- b. *Element 2.* For the inner fillet weld,

$$\left(\frac{\pi}{3} \right) (20.75)(0.375)(0.707)(10,800) = 62,200 \text{ lb}$$

- c. *Element 3.* For the groove weld in shear,

$$\left(\frac{\pi}{3} \right) (20.75)(0.1875)(9,450) = 38,600 \text{ lb}$$

d. *Element 4.* For the groove weld in tension,

$$\left(\frac{\pi}{3}\right)(20.75 + 0.375)(0.5)(11.810) = 131,000 \text{ lb}$$

e. *Element 5.* For the manhole neck in shear,

$$\left(\frac{\pi}{3}\right)(20.375)(0.375)(12.600) = 101,100 \text{ lb}$$

For the investigation of possible paths of failure through the attachment elements, the following loads and strengths shall be compared.

The combined load on Elements 1, 3, and 5, which attach the added reinforcement to the tank wall, is calculated as follows:

$$(8.25 - 1.76)(18,000) = 116,900 \text{ lb}$$

The combined strength of Elements 1, 3, and 5 is as follows:

$$115,300 + 38,600 + 101,100 = 255,000 \text{ lb}$$

This value is more than adequate.

The combined load on Elements 1 and 4, which attach to the tank wall the added reinforcement plus that section of the manhole neck which coincides with the thickness of the tank wall, is calculated as follows:

$$[8.25 - 1.76 + (2)(0.5)(0.375)](18,000) = 123,600 \text{ lb}$$

The combined strength of Elements 1 and 4 is as follows:

$$115,300 + 131,000 = 246,300 \text{ lb}$$

This value is more than adequate.

The combined load on Elements 2 and 5, from the standpoint of developing the strength of the reinforcement in the manhole neck, is as follows:

$$(0.89)(18,000) = 16,000 \text{ lb}$$

The strength of either of these elements alone exceeds this requirement.

F.5.2 EXAMPLE 2

The 20-in. inside-diameter nozzle shown in Figure F-6 is located in solid plate in the sidewall of a cylindrical storage tank 148 ft in diameter in an area where the thickness of the wall plate, t_w , is 1½ in. A corrosion allowance of 0.10 in. is required on all surfaces of the tank exposed to the stored liquid. The total internal pressure, $P_1 + P_g$, at the center of the

opening is 24.9 lbf/in.² gauge. The thickness of the wall plate, t , required by 5.10.3 for the latitudinal unit forces, T_2 , acting at this level is 1.44 in. The nozzle neck is fabricated by welding from ½-in. plate. The materials in the tank wall, the nozzle neck, and the reinforcing pad conform to ASTM A 442, Grade 55. The main joints in the tank wall are fully radiographed, double-welded butt joints. The longitudinal joint in the nozzle neck is of the same type but is not radiographed; however, the longitudinal joint and all other parts of the nozzle-and-wall-plate assembly have been shop stress relieved after fabrication, as required by 5.25. The adequacy of the reinforcement and attachment welds shown in Figure F-6 shall be determined.

The net thickness required for a seamless tank wall at the horizontal centerline of the opening, exclusive of the corrosion allowance, is calculated as follows:

$$t_r = (1.44 - 0.1)(1.00) = 1.34 \text{ in.}$$

The net thickness required for the nozzle neck, exclusive of the corrosion allowance, is calculated as follows:

$$t_{rn} = \frac{(24.9)(10 + 0.1)}{(16,500)(0.85)} = 0.018 \text{ in.}$$

Note: A net thickness of not less than 3/8 in., exclusive of the corrosion allowance, must be provided in the nozzle neck to satisfy the provisions of 5.19.2, Item b, but this requirement does not affect the value of t_{rn} used for reinforcement computations.

To determine the length of the nozzle neck within the limits of reinforcement, the smaller of the following calculated values shall be used:

$$(2.5)(1.5 - 0.1) = 3.5 \text{ in.}$$

$$(2.5)(0.5 - 0.1) + 1.5 = 2.5 \text{ in.}$$

The minimum sizes of the attachment welds permitted by Figure 5-8, panel I, are calculated as follows:

a. For the outer fillet weld,

$$\frac{(0.5)(0.75)}{0.707} = 0.53 \text{ in.}$$

b. For the inner fillet weld,

$$\frac{(0.25)}{0.707} = 0.35 \text{ in.}$$

c. For the groove weld between the tank wall and the nozzle neck,

$$(0.7)(0.5 - 0.1) + 0.1 = 0.38 \text{ in.}$$

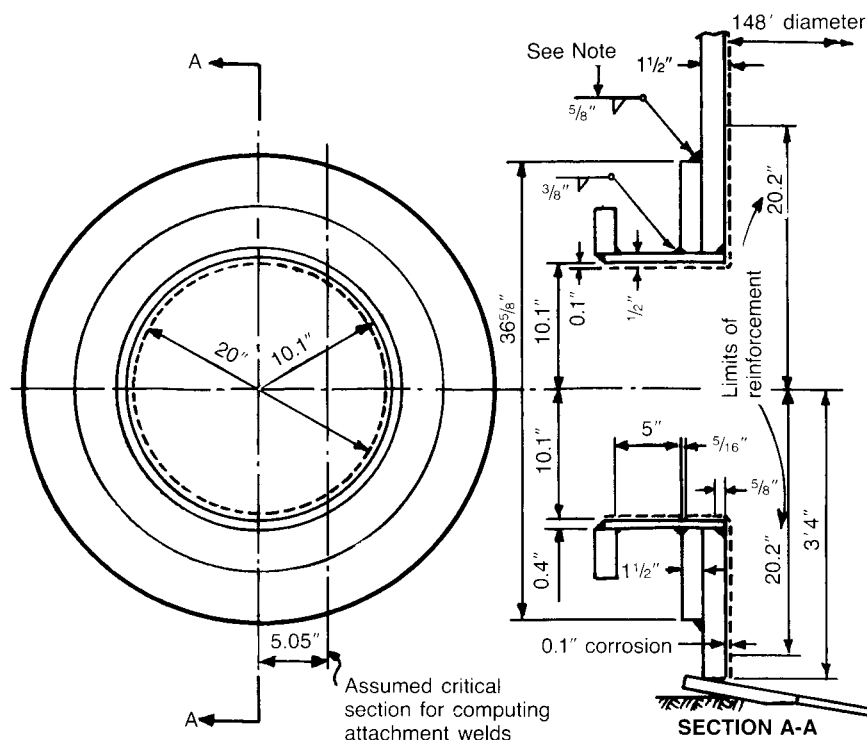

Note: Upon computation, a $\frac{5}{8}$ -inch outer fillet weld was found to be inadequate for strength requirements. The outer weld should be a 1-inch fillet weld.

Figure F-6—Example of a Reinforced Opening (See F.5.2)

d. For the groove weld between the pad and the nozzle neck,

$$(0.7)(0.5 - 0.1) = 0.28 \text{ in.}$$

Therefore, the weld sizes used meet the minimum requirements of Figure 5-8, panel 1.

The area of reinforcement required at the vertical centerline of the opening is calculated as follows:

$$\begin{aligned} A_r &= [20 + (2)(0.1)](1.44 - 0.1)(1.00) \\ &= 27.07 \text{ in.}^2 \end{aligned}$$

The areas of reinforcement provided are as follows:

a. From excess thickness in the tank wall,

$$A_1 = (20 + 0.2) \times (1.5 - 0.1 - 1.34) = 1.21 \text{ in.}^2$$

b. From excess thickness in the nozzle neck,

$$A_2 = 2 \times 2.5 \times (0.5 - 0.1 - 0.018) = 1.91 \text{ in.}^2$$

c. In fillet welds,

$$A_3 = 2 \times 0.5 \times [(0.625)^2 + (0.375)^2] = 0.53 \text{ in.}^2$$

d. In the reinforcing pad,

$$A_4 = 1.5 \times (36.625 - 21) = 23.44 \text{ in.}^2$$

The total area of reinforcement provided is 27.09 in.² which is adequate.

The allowable unit stress values for the attachment elements are as follows:

a. For the outer and inner fillet welds,

$$16,500 \times 0.60 = 9900 \text{ lbf/in.}^2$$

b. For tension across the groove welds,

$$16,500 \times 0.875 \times 0.70 = 10,100 \text{ lbf/in.}^2$$

c. For shear in the nozzle neck,

$$16,500 \times 0.8 \times 0.875 = 11,500 \text{ lbf/in.}^2$$

The strengths of the attachment elements beyond the critical section shown in Figure F-6 are as follows:

- a. Element 1. For the outer fillet weld,

$$\left[\left(\frac{\pi}{2} \right) (36.625) - (2)(5.05) \right] (0.625)(0.707)(9900) \\ = 207,400 \text{ lb}$$

- b. Element 2. For the inner fillet weld,

$$\left(\frac{\pi}{3} \right) (21)(0.375)(0.707)(9900) = 57,9000 \text{ lb}$$

- c. Element 3. For the groove weld between the tank wall and the nozzle neck, in tension,

$$\left(\frac{\pi}{3} \right) (21)(0.625 - 0.1)(10.100) = 116,900 \text{ lb}$$

- d. Element 4. For the groove weld between the pad and the nozzle neck, in tension,

$$\left(\frac{\pi}{3} \right) (21)(0.3125)(10.100) = 69,400 \text{ lb}$$

- e. Element 5. For the nozzle neck in shear,

$$\left(\frac{\pi}{3} \right) (20.6)(0.4)(11.500) = 99,500 \text{ lb}$$

For the investigation of possible paths of failure through the attachment elements, the following loads and strengths shall be compared.

The combined load on Elements 1 and 5, which attach the added reinforcement to the tank wall, is calculated as follows:

$$(27.07 - 1.21)(16,500) = 426,700 \text{ lb}$$

The combined strength of Elements 1 and 5 is as follows:

$$207,400 + 99,500 = 306,900 \text{ lb}$$

This value is inadequate.

If the size of the outer fillet weld were increased to 1 in. instead of $\frac{5}{8}$ in., the strength of Element 1 would become the following:

$$\left[\left(\frac{\pi}{2} \right) (36.625) - (2)(5.05) \right] (1.0)(0.707)(9900) \\ = 331,800 \text{ lb}$$

The combined strength of Elements 1 and 5 would now become the following:

$$331,800 + 99,500 = 431,300 \text{ lb}$$

This value would be adequate. Hence, the size of the outer fillet weld shall be increased to 1 in.

The combined load on Elements 1 and 3, which attach to the tank wall the added reinforcement plus that section of the nozzle neck which coincides with the thickness of the tank wall, is calculated as follows:

$$[(27.07 - 1.21) + (2)(1.4)(0.4)](16,500) = 445,670 \text{ lb}$$

The combined strength of Elements 1 and 3, based on the size of the outer fillet weld being increased to 1 in., is as follows:

$$331,800 + 116,900 = 448,700 \text{ lb}$$

This value is adequate.

The combined load on Elements 2, 4, and 5, from the standpoint of developing the strength of the reinforcement in the nozzle neck, is calculated as follows:

$$(1.91)(16,500) = 31,500 \text{ lb}$$

The strength of any one of these three elements alone exceeds this requirement.

F.5.3 EXAMPLE 3

A cylindrical nozzle with a 12-in. inside diameter is located in solid plate in the sidewall of a cylindrical storage tank 60 ft in diameter so that its axis lies in a horizontal plane and forms an angle of 55° with a perpendicular to the sidewall at the point of intersection, as shown in Figure F-7. The thickness of the sidewall plate, t_w , in this area is $\frac{5}{8}$ in., and no corrosion allowance is required. The total internal pressure, $P_1 + P_g$, at the center of the opening is 26.1 lbf/in.² gauge. The thickness of the wall plate, t , required by 5.10.3 for the latitudinal unit forces, T_2 , acting at this level is 0.57 in. The nozzle neck is seamless steel pipe and conforms to ASTM A 53, Grade A; the materials in the tank wall and reinforcing pad conform to ASTM A 442, Grade 55. The main joints in the tank walls are fully radiographed, double-welded butt joints. The adequacy of the reinforcement and attachment welds shown in Figure F-7 shall be determined.

The net thickness required for a seamless tank wall at the horizontal centerline of the opening is calculated as follows:

$$t_r = (0.57)(1.00) = 0.57 \text{ in.}$$

The thickness required for the nozzle neck is calculated as follows:

$$t_{rn} = \frac{(26.1)(6)(1.00)}{(14,400)(1.00)} = 0.011 \text{ in.}$$

Note: A thickness of $\frac{3}{8}$ in. must be provided in the nozzle neck to satisfy the provisions of 5.19.2, item b, but this requirement does not affect the value of t_{rn} used for reinforcement computations.

To determine the length of the nozzle neck within the limits of reinforcement, the smaller of the following calculated values shall be used:

$$(2.5)(0.625) = 1.56 \text{ in.}$$

$$(2.5)(0.375) + 0.75 = 1.69 \text{ in.}$$

The minimum size of the outer fillet weld permitted by Figure 5-8, panel m, is calculated as follows:

$$\frac{(0.5)(0.625)}{0.707} = 0.44 \text{ in.}$$

The minimum size of the inner fillet weld permitted by Figure 5-8, panel m, is calculated as follows:

$$\frac{0.25}{0.707} = 0.35 \text{ in.}$$

Therefore, the weld sizes used meet the minimum requirements of Figure 5-8, panel m.

The area of reinforcement required at the vertical centerline of the opening is calculated as follows:

$$A_r = (12)(0.57)(1.00) = 6.84 \text{ in.}^2$$

The areas of reinforcement provided are as follows:

a. From excess thickness in the tank wall,

$$A_1 = (12)(0.625 - 0.57) = 0.66 \text{ in.}^2$$

b. From excess thickness in the nozzle neck,

$$A_2 = \frac{(2)(1.56)(0.375 - 0.011)(14,400)}{16,500} \\ = 0.99 \text{ in.}^2$$

c. In fillet welds,

$$A_3 = (2)(0.5)[(0.5)^2 + (0.375)^2] 0.39 \text{ in.}^2$$

d. In the reinforcing pad,

$$A_3 = (19.5 - 12.75)(0.75) = 5.06 \text{ in.}^2$$

The total area of reinforcement provided is 7.10 in.^2 , which is adequate.

The allowable unit stress values for the attachment elements are as follows:

a. For the outer fillet weld,

$$16,500 \times 0.60 = 9900 \text{ lbf/in.}^2$$

b. For the inner fillet weld,

$$14,400 \times 0.60 = 8640 \text{ lbf/in.}^2$$

c. For groove welds in tension against the nozzle neck,

$$14,400 \times 0.75 \times 0.875 = 9320 \text{ lbf/in.}^2$$

d. For groove welds in tension against the tank wall,

$$16,500 \times 0.75 \times 0.875 = 10,660 \text{ lbf/in.}^2$$

e. For the groove weld in shear,

$$16,500 \times 0.8 \times 0.75 \times 0.875 = 8530 \text{ lbf/in.}^2$$

f. For the nozzle neck in shear,

$$14,400 \times 0.8 \times 0.875 = 10,080 \text{ lbf/in.}^2$$

The strengths of the attachment elements beyond the critical section shown in Figure F-7 are as follows:

a. Element 1. For the outer fillet weld,

$$[2.22\sqrt{(14.25)^2 + (9.75)^2} - (2)(5.1)] \times (0.500)(0.707)(9900) \\ = 98,500 \text{ lb}$$

b. Element 2. For the inner fillet weld,

$$2.22\sqrt{(10.77)^2 + (6.56)^2} - (2)(5.1) \times (0.375)(0.707)(8640) \\ = 39,400 \text{ lb}$$

c. Element 3. For the groove weld between the tank wall and the nozzle neck, in tension,

$$(17.2)(0.625)(10,660) = 114,500 \text{ lb}$$

d. Element 4. For the groove weld between the pad and the nozzle neck, in tension,

$$[2.22\sqrt{(10.58)^2 + (6.375)^2} - (2)(5.1)] \times (0.75)(9320) \\ = 120,000 \text{ lb}$$

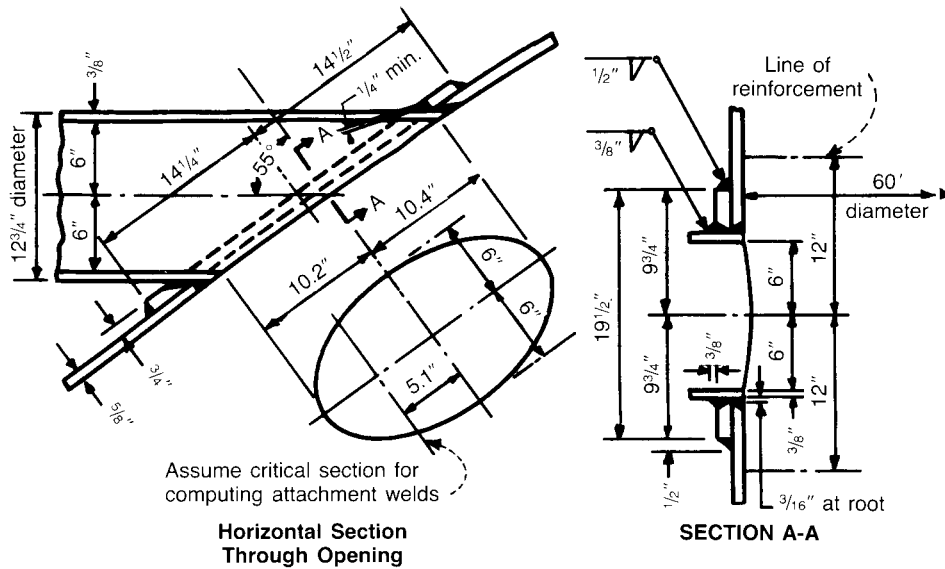

Figure F-7—Example of a Reinforced Opening (See F.5.3)

e. Element 5. For the nozzle neck in shear,

$$[2.22\sqrt{(10.39)^2 - (6.19)^2} - (2)(5.1)] \times (0.375)(10,080) = 62,900 \text{ lb}$$

f. Element 6. For groove welds in shear,

$$(17.2)(0.1875)(8530) = 27,500 \text{ lb}$$

For the investigation of possible paths of failure through the attachment elements, the following loads and strengths shall be compared.

The combined load on Elements 1, 5, and 6, which attach the added reinforcement to the tank wall, is calculated as follows:

$$(6.84 - 0.66)(16,500) = 102,000 \text{ lb}$$

The combined strength of Elements 1, 5, and 6 is as follows:

$$98,500 + 62,900 + 27,500 = 188,900 \text{ lb}$$

This value is adequate.

The combined load on Elements 1 and 3, which attach to the tank wall the added reinforcement plus that section of the nozzle neck which coincides with the thickness of the tank wall, is calculated as follows:

$$\left[(6.84 - 0.66) + (2)(0.625)(0.375) \left(\frac{14.400}{16.500} \right) \right] \times (0.500) (0.707) (9900) = 98,500 \text{ lb}$$

The combined strength of Elements 1 and 3 is as follows:

$$98,500 + 114,500 = 213,000 \text{ lb}$$

This value is adequate.

The combined load on Elements 2, 4, and 5, from the standpoint of developing the strength of the reinforcement in the nozzle wall, is calculated as follows:

$$(0.99)(16,500) = 16,400 \text{ lb}$$

The strength of any one of these three elements alone exceeds this requirement.

The combined load on Elements 1 and 6, from the standpoint of developing the strength of the reinforcing pad, is calculated as follows:

$$(5.06)(16,500) = 83,490 \text{ lb}$$

The combined strength of Elements 1 and 6 is as follows:

$$98,500 + 27,500 = 126,000 \text{ lb}$$

This value is adequate.

F.5.4 EXAMPLE 4

The pressed-steel, round manhole with a 20-in. inside diameter shown in Figure F-8 is located in solid plate in spherical portion of a torispherical roof on a cylindrical storage tank 72 ft in diameter. The internal pressure, P_g , on the underside of the roof is 15 lbf/in.² gauge. The thickness, t , of the roof plate required by 5.10.3 for the spherical portion of

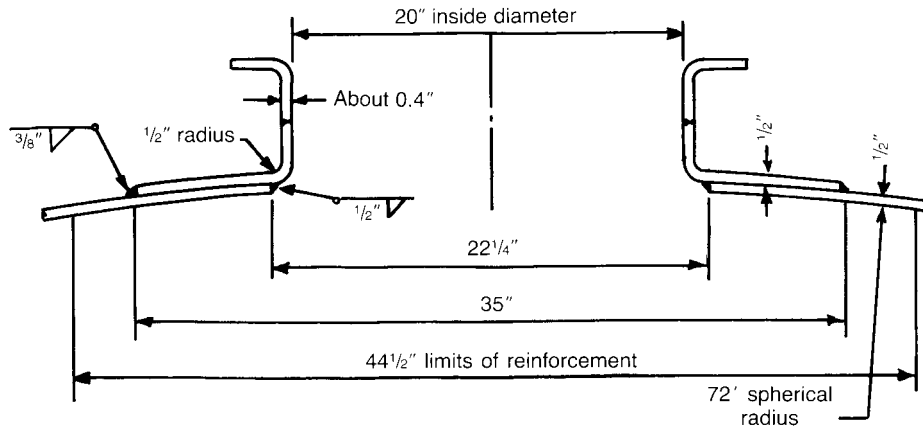

Figure F-8—Example of a Reinforced Opening (See F5.4)

the roof is 1/2 in., which is exactly the thickness provided. No corrosion allowance is required. The materials in the roof plates and manhole frame conform to ASTM A 283, Grade C; the main joints in the roof are double-welded butt joints, spot radiographed in accordance with 7.16 and 7.17. The adequacy of the reinforcement and attachment welds shown in Figure F-8 shall be determined.

The net thickness required for a seamless tank wall at the location of the manhole is calculated as follows:

$$t_r = (0.5)(0.85) = 0.425 \text{ in.}$$

The thickness required for the manhole neck is calculated as follows:

$$t_{rn} = \frac{(15)(10)(1.00)}{15.200} = 0.010 \text{ in.}$$

Note: A thickness of not less than 3/8 in. must be provided in the manhole neck to satisfy the provisions of 5.19.2, item b, but this requirement does not affect the value of t_{rn} used for reinforcement computations.

To determine the length of the manhole neck within the limits of reinforcement, the smaller of the following calculated values shall be used:

$$(2.5)(0.5) = 1.25 \text{ in.}$$

$$(2.5)(0.4) + 0.5 = 1.5 \text{ in.}$$

The minimum size of the outer fillet weld permitted by Figure 5-8, panel i, is calculated as follows:

$$\frac{(0.5)(0.5)}{0.707} = 0.35 \text{ in.}$$

The minimum size of the inner fillet weld permitted by Figure 5-8, panel i, is calculated as follows:

$$\frac{(0.5)(0.7)}{0.707} = 0.50 \text{ in.}$$

Therefore, the weld sizes used meet the minimum requirements of Figure 5-8, panel i.

The area required at the centerline of the opening is calculated as follows:

$$A_r = (22.25)(0.5)(0.85) = 9.46 \text{ in.}^2$$

The areas of reinforcement provided are as follows:

a. From excess thickness in the spherical head,

$$A_1 = (22.25)(0.500 - 0.425) = 1.67 \text{ in.}^2$$

b. From excess thickness in the formed manhole neck,

$$A_2 = 2 \left[\frac{\pi(1^2 - 0.5^2)}{4} + (1.25 - 1)(0.4) - (1.25)(0.010) \right] = 1.36 \text{ in.}^2$$

c. In fillet welds,

$$A_3 = 2(0.5)[(0.375)^2 + (0.5)^2] = 0.39 \text{ in.}^2$$

d. In the dished reinforcing collar,

$$A_4 = (0.5)(35 - 21.8) = 6.60 \text{ in.}^2$$

The total area of reinforcement provided is 10.02 in.², which is adequate.

The allowable unit stress value for the outer and inner fillet welds is calculated as follows:

$$(15,200)(0.6) = 9120 \text{ lbf/in.}^2$$

The strength of the attachment elements beyond the critical section is as follows:

a. Element 1. For the outer fillet weld,

$$\frac{\pi}{2}(35)(9120)(0.707)(0.375) = 132,000 \text{ lb}$$

Note: It should be assumed that the critical section for computing the strength of the attachment is at the centerline of the opening as indicated in 5.16.8.1.

b. Element 2. For the inner fillet weld,

$$\frac{\pi}{2}(22.25)(9120)(0.707)(0.50) = 112,600 \text{ lb}$$

For the investigation of possible paths of failure through the attachment elements, the following loads and strengths shall be compared.

The combined load on Elements 1 and 2, which attach the added reinforcement to the roof, is calculated as follows:

$$(9.46 - 1.67)(15,200) = 118,400 \text{ lb}$$

The combined strength of Elements 1 and 2 is as follows:

$$132,900 + 112,600 = 245,500 \text{ lb}$$

This value is more than adequate.

For Committee Use Only

APPENDIX G—CONSIDERATIONS REGARDING CORROSION ALLOWANCE AND HYDROGEN-INDUCED CRACKING

G.1 Tank Groups Based on Corrosion Rate

All large low-pressure tanks of the type covered by this standard may be classified under one of the following general groups based on corrosion:

- a. Tanks in which corrosion rates may be definitely established by reason of accurate knowledge, available to the designer, covering the chemical characteristics of whatever substances the tanks are to contain. Such knowledge may, in the case of standard commercial products, be obtained from published sources or, whenever special processes are involved, from reliable records compiled from results of previous observations by the user or others under similar conditions of operation.
- b. Tanks in which corrosion rates, although known to be relatively high, are either variable or indeterminate in magnitude.
- c. Tanks in which corrosion rates, although indeterminate, are known to be relatively low.
- d. Tanks in which corrosion effects are known to be negligible or entirely absent.

G.2 Corrosion Allowance

G.2.1 In cases in which the rate of corrosion is closely predictable, additional metal thickness over and above that required for the initial operating conditions shall be provided and shall be at least equal to the expected corrosion loss during the desired life of the tank.

G.2.2 When corrosion effects are indeterminate before the tank is designed (although they are known to be inherent to some degree in the service for which the tank is to be used), and when corrosion is incidental, localized, or variable in rate and extent, the best judgement of the designer must be exer-

cised in establishing reasonable maximum excess tank wall thicknesses. For all tanks that come under this classification, a minimum corrosion allowance of $1/16$ in. shall be provided. This minimum allowance may, of course, be increased according to the judgement of the designer.

G.2.3 In all cases in which corrosion effects can be shown to be negligible or entirely absent, no excess thickness need be provided.

G.3 Service Conditions and Hydrogen-Induced Cracking

When the service conditions might include the presence of hydrogen sulfide or other conditions that may promote hydrogen-induced cracking effects, particularly near the bottom of the shell at the shell-to-bottom connections, care shall be taken to ensure that the materials and details of construction of the tank are adequate to resist hydrogen-induced cracking. The purchaser shall consider restricting the sulphur content of the material to be stored through thickness testing of the steel, laboratory surveillance tests, and the use of internal tank coatings to reduce the possibility of hydrogen-induced cracking. The hardness of the welds contacting these environments, including the heat-affected zones, shall be considered. The weld metal and adjacent heat-affected zone often contain a zone of hardness that is well in excess of a value of 22 on the Rockwell C scale and could be expected to be more susceptible to cracking than would unwelded metal. Any hardness criteria shall be a matter of agreement between the purchaser and the manufacturer and shall be based on an evaluation of the expected hydrogen sulfide concentration in the product, the possibility of moisture being present on the inside metal surface, and the strength and hardness characteristics of base metal and weld metal.

**For Committee
Use Only**

APPENDIX H—RECOMMENDED PRACTICE FOR USE OF PREHEAT, POST-HEAT, AND STRESS RELIEF

H.1 Introduction

The majority of tanks covered by this standard are usually not subjected to a conventional stress-relief post-heat treatment after erection is completed. However, the very nature of these tanks and their expected service requires that the utmost care be taken to obtain completed tanks that have the highest safety factor possible with regard to notch toughness.

The thermal stress-relief treatment performed on pressure vessels is recognized as a means for reducing the probability of brittle failures. Evidence is accumulating that shows the benefit of improving notch toughness by metallurgical changes rather than by relief of residual stresses.

H.2 Thickness as It Affects Preheat and Post-Heat Requirements

Plate with thicknesses below $\frac{1}{2}$ in. is reasonably notch tough. In most steels, when the plate thickness exceeds $\frac{3}{4}$ –1 in., notch toughness, particularly as welded, decreases sharply. The decrease in notch toughness can be minimized by the conventional post-heat treatment and, in many steels, by preheat treatment. The benefits of preheat treatment in steels $\frac{3}{4}$ –1 in. thick have been demonstrated; similar benefits could be expected in thicker steels, but sufficient experimental data are currently lacking.

H.3 Post-Heat Treatment (Stress Relief)

The post-heat treatment now performed on pressure vessels is of established value, although the mechanism by which the improvement is realized may be open to debate. Post-heat treatment of tank sections when the plate thickness exceeds $1\frac{1}{4}$ in. is required as stated in 5.25. In special cases, the possibilities of post-heat treatment after erection should be explored. Post-heating an insulated tank may be possible if an ample source of heat is readily available and if the rigidity of the tank is adequate.

When the service conditions are expected to produce stress corrosion cracking, relief of stresses is necessary. Preheat treatment has not been shown to be an adequate substitute for post-heat treatment when it is applied to avoid stress corrosion cracking.

H.4 Preheat Treatment

Many laboratory tests have shown preheat treatment of carbon steel to 300°F–400°F to be the equivalent of the post-heat treatment at no less than 1100°F insofar as the physical properties of the weldment are concerned.^{40,41} Some tests have indicated a slight advantage of the post-heat treatment. Most of the tests have been made on plates $\frac{3}{4}$ –1 in. thick; results must be viewed with caution if preheating is applied appreciably beyond this thickness range. However, for all practical purposes, improvement resulting from preheating is sufficiently well established so that preheat should be considered for field fabrication of plates over $\frac{3}{4}$ -in. thick whenever toughness of the tank is highly desired and the thermal post-heat treatment is impractical.

Preheating should be performed by heating and maintaining this heat in appreciable lengths of the joint to be welded, preferably using a strip burner with a mild flame rather than a harsh flame such as that from a cutting torch. Electrical strip heaters are available and have been found to be satisfactory. The preheat of 300°F should be checked with a temperature-sensitive crayon, or similarly accurate means, so that the steel 4 in. (or four times the plate thickness, whichever is greater) on each side of the joint will be maintained at the minimum preheat temperature. Ring burners or heaters are recommended for nozzle and manway welds. At no time during the welding should the base metal fall below a temperature of 300°F.

⁴⁰Robert D. Stout, "The Preheating and Postheating of Pressure Vessel Steels," *Welding Journal New York*, Research Supplement 32 [1], 14s–22s, 1953 (including bibliography).

⁴¹Harry Uldine, "Preheat Versus Postheat", a paper prepared in connection with the work of Subcommittee 8 of ASME B31.1.

**For Committee
Use Only**

APPENDIX I—SUGGESTED PRACTICE FOR PEENING

I.1 General

Peening is used to eliminate distortion in thin plates and to prevent cracking in thick plates when the weld is built up of several layers of weld metal. Peening is intended to reduce the internal stresses introduced in welded structures because the weld shrinks more than the relatively cold adjacent base metal. Proper peening strains the stressed weld metal above its yield point and, in this manner, adjusts the stresses in proportion to the amount of flow caused by peening.

I.2 Effective Peening

Effective peening occurs below the red-hot temperature. Peening is wasted when it occurs above a temperature at which the weld metal begins to take on strength. The first two layers and the last layer of weld metal must not be peened.

To be effective, peening must move the weld metal. The shape, size, and hardness of peening tools are important. Bruises and surface roughness of the weld metal caused by peening are not objectionable, since these are melted by the deposition of subsequent layers of weld metal.

I.3 Peening as an Alternative to Thermal Stress Relief

When peening occurs as an alternative to thermal stress relief under permissible procedures, it shall be done carefully to minimize distortion of the weldment. Some steels that are weldable have to be peened sufficiently to temporarily create stresses in the reverse direction, which will disappear on cooling. These are the steels which get so hard when they are cold that the metal is only burnished by the peening tool instead of being cold-worked. When peening is done to avoid the formation of cracks on welds that are subsequently to be stress relieved, underpeening may be satisfactory.

I.4 Factors Involved in Peening

I.4.1 GENERAL

For peening to be acceptable or dependable as a means of stress relief, a thorough study must be made of all the factors involved, including the type of steel, the thickness of the weld, and the thicknesses of successive layers of welding (see 6.19.2). Two guides to satisfactory results are outlined in I.4.2 and I.4.3.

I.4.2 AMOUNT OF PEENING NECESSARY

An approximation of the amount of peening that is necessary may be obtained by welding two small plates of a given material and thickness, with one plate held rigidly and the other free to move as the weld shrinks. The peening required to overcome the shrinkage gives a fair idea of the degree of peening that will be required in the actual operation.

I.4.3 MEASUREMENTS DURING WELDING AND PEENING

Punch marks shall be made on opposite sides of the weld, and the distance between these marks shall be kept within $\frac{1}{32}$ in. by peening during the welding of the seam. The initial measurement shall be made after two layers of weld metal have been deposited. After the weld has been built up to a depth of $1\frac{1}{4}$ – $1\frac{1}{2}$ in., the likelihood of deviation in the distance between punch marks is greatly reduced, since the stresses caused by shrinkage of the recently deposited weld metal are more fully resisted by the cooler prior layers. Cracking of unpeened welds in ordinary steel is most likely to occur at this point. If the peening has been done so that the deviation in distance between punch marks is kept to a minimum up to this point, the same degree of peening for the remainder of the weld will protect the weld from cracking.

**For Committee
Use Only**

APPENDIX J—(RESERVED FOR FUTURE USE)

**For Committee
Use Only**

**For Committee
Use Only**

APPENDIX K—SUGGESTED PRACTICE FOR DETERMINING THE RELIEVING CAPACITY REQUIRED

K.1 General

This appendix attempts to outline a safe and reasonable practice to be used for the usual environment and operating conditions. The many variables that must be considered in connection with tank venting problems make it impracticable to set forth definite, simple rules. Engineering studies for any particular tank may show that it is desirable to use either a larger or smaller venting capacity than that estimated in accordance with these rules.

K.2 Determination of Required Capacity

The aggregate capacities required for any vent valves, pressure-relieving valves, and/or vacuum-relieving valves to be provided should be determined as follows:

- a. For thermal breathing and product movement, the rules given in API Std 2000 shall be followed. The required capacity as the result of the product movement into the tank, given in Std 2000, shall be multiplied by the ratio of the absolute tank pressure to atmospheric pressure (14.7 lbf/in.² absolute).
- b. For supplemental safety pressure-relieving devices to take care of extra venting capacity required in case of external fire exposure, the rules in API Standard 2000 shall be followed.

For Comment Use Only

**For Committee
Use Only**

APPENDIX L—SEISMIC DESIGN OF STORAGE TANKS

L.1 Scope

This appendix establishes recommended minimum basic requirements that the purchaser may specify for the design of storage tanks subject to seismic load.⁴² These requirements represent accepted practices used for application to flat-bottom tanks; however, other procedures and applicable factors or additional requirements may be specified by the purchaser or jurisdictional authorities. Any deviation from the requirements of this appendix must be agreed to by the purchaser and the manufacturer.

Although the factors *Z*, *I*, and *S* may apply to any structure, the seismic design requirements of Appendix L are intended for flat-bottom tanks, not for skirt or column supported tanks.

L.2 General

L.2.1 The design procedure considers the following two response modes of the tank and its contents:

- a. The relatively high-frequency amplified response to lateral ground motion of the tank shell and roof, together with the portion of the liquid contents that moves in unison with the shell.
- b. The relatively low-frequency amplified response of the portion of the liquid contents in the fundamental sloshing mode.

L.2.2 The design requires the determination of the hydrodynamic mass associated with each mode and the lateral force and overturning moment applied to the shell, which result from the response of the masses to lateral ground motion. Provisions are included to ensure the stability of the tank shell against overturning and to preclude buckling of the tank shell due to longitudinal compression.

L.2.3 No provisions are included regarding the increase in hoop tension due to horizontal and vertical seismic forces. Shell thicknesses are not affected by the lateral-force coefficients specified in L.3.3, taking into account generally accepted allowable stress increase and ductility ratios. Coefficients determined by the alternative method in L.3.3.3 may produce significant dynamic hoop tension that should then be considered.

⁴²The basis for these provisions, together with the formulas for the design curves in Figures L-2 through L-5, and information for calculating other seismic effects, is covered in a paper by R.S. Wozniak and W.W. Mitchell, "Basis of Seismic Design Provisions for Welded Steel Oil Storage Tanks," 1978 Proceedings-Refining Department, API, Washington DC, 1978, Volume 57, pp.485 – 501.

Table L-1—Seismic Zone Tabulation for Some Areas Outside the United States

Location	Seismic Zone
ASIA	
Turkey	
Ankara	2B
Karamursel	3
ATLANTIC OCEAN AREA	
Azores	2B
Bermuda	1
CARIBBEAN SEA	
Bahama Islands	1
Canal Zone	2B
Leeward Islands	3
Puerto Rico	3
Trinidad Island	2B
NORTH AMERICA	
Greenland	1
Iceland	
Keflavik	3
PACIFIC OCEAN AREA	
Caroline Island	
Koror, Paulau	2B
Ponape	0
Johnston Island	1
Kwajalein	
Mariana Islands	
Guam	3
Saipan	3
Tinian	3
Marcus Island	1
Okinawa	3
Philippine Islands	3
Samoa Islands	3
Wake Island	0

Note: No earthquake design is required for Zone 0.

L.3 Design Loading

L.3.1 OVERTURNING MOMENT

Note: The overturning moment determined in this section is the moment applied to the bottom of the shell only. The tank foundation is subjected to an additional overturning moment due to the lateral displacement of the tank contents; this additional moment may need to be considered in the design of some foundations, such as pile-supported concrete mats.

The overturning moment due to seismic forces applied to the bottom of the shell shall be determined using the following equation:

$$M = ZI(C_1 W_s X_s + C_1 W_r H_t + C_1 W_1 X_1 + C_2 W_2 X_2)$$

where

M = overturning moment applied to the bottom of the tank shell, in ft-lbs,

Z = seismic zone factor (horizontal seismic acceleration) as determined by the purchaser or the appropriate governmental authority having jurisdiction. The seismic zone maps of Figure L-1 or the seismic zone tabulation, Table L-1 for areas outside the United States or the National Building Code of Canada may be used as an aid to determine the seismic zone. Table L-2 can be used to determine the seismic zone factor,

I = importance factor

= 1.0 for all tanks, except when a larger importance factor is specified by the purchaser. It is recommended that the I factor not exceed 1.25 and that this maximum value be applied only to tanks used for storage of toxic or explosive substances in areas where an accidental release of product would be considered to be dangerous to the safety of the general public,

C_1, C_2 = lateral earthquake force coefficients determined in accordance with L.3.3,

W_s = total weight of the tank shell and any insulation, in lbs,

X_s = height from the bottom of the tank shell to the center of gravity of the shell, in ft,

W_r = total weight of the tank roof, including any insulation, suspended deck, or snow load (furnished or as specified by the purchaser), in lbs,

H_r = total height of the tank shell, in ft,

W_1 = weight of the effective mass of the tank contents that moves in unison with the tank shell, as determined in accordance with L.3.2.1, in lbs,

X_1 = height from the bottom of the tank shell to the centroid of lateral seismic force applied to W_1 , as determined in accordance with L.3.2.2, in ft,

W_2 = weight of the effective mass of the first mode sloshing contents of the tank, as determined in accordance with L.3.2.1, in lbs,

X_2 = height from the bottom of the tank shell to the centroid of lateral seismic force applied to W_2 , as determined in accordance with L.3.2.2, in ft,

Table L-2—Seismic Zone Factor
(Horizontal Acceleration)

Seismic Zone (from Fig. L-1 or Other Source)	Seismic Zone Factor Horiz. Acceleration
1	0.075
2A	0.15
2B	0.20
3	0.30
4	0.40

Note: No earthquake design is required for Zone 0.

L.3.2 EFFECTIVE MASS OF TANK CONTENTS

L.3.2.1 The effective masses W_1 and W_2 may be determined by multiplying W_T by the ratios W_1/W_T and W_2/W_T , respectively, obtained from Figure L-2 for the ratio D/H . The variables are defined as follows:

W_T = total weight of the tank contents, in lbs. (The product's specific gravity shall be specified by the purchaser.)

$D = 2R_c$ = diameter of the tank, in ft. (See 5.12.4.1 for a definition of R_c .)

H = maximum design product height, in ft.

L.3.2.2 The heights from the bottom of the tank shell to the centroids of the lateral seismic forces applied to W_1 and W_2 and X_1 and X_2 may be determined by multiplying H by the ratios X_1/H and X_2/H , respectively, obtained from Figure L-3 for the ratio of D/H .

L.3.2.3 The curves in Figures L-2 and L-3 are based on a modification of the equations presented in ERDA Technical Information Document 7024. Alternative, W_1 , W_2 , X_1 , and X_2 may be determined by other analytical procedures based on the dynamic characteristics of the tank.

L.3.3 LATERAL-FORCE COEFFICIENTS

L.3.3.1 The lateral force coefficient C_1 shall be 0.60, unless the total product of ZIC_1 and ZIC_2 are determined by the method in L.3.3.3.

L.3.3.2 The lateral-force coefficient C_2 shall be determined as a function of the natural period of the first mode sloshing, T , and the soil conditions at the tank site unless otherwise determined by the method in L.3.3.3.

When T is less than or equal to 4.5,

$$C_2 = \frac{0.75S}{T}$$

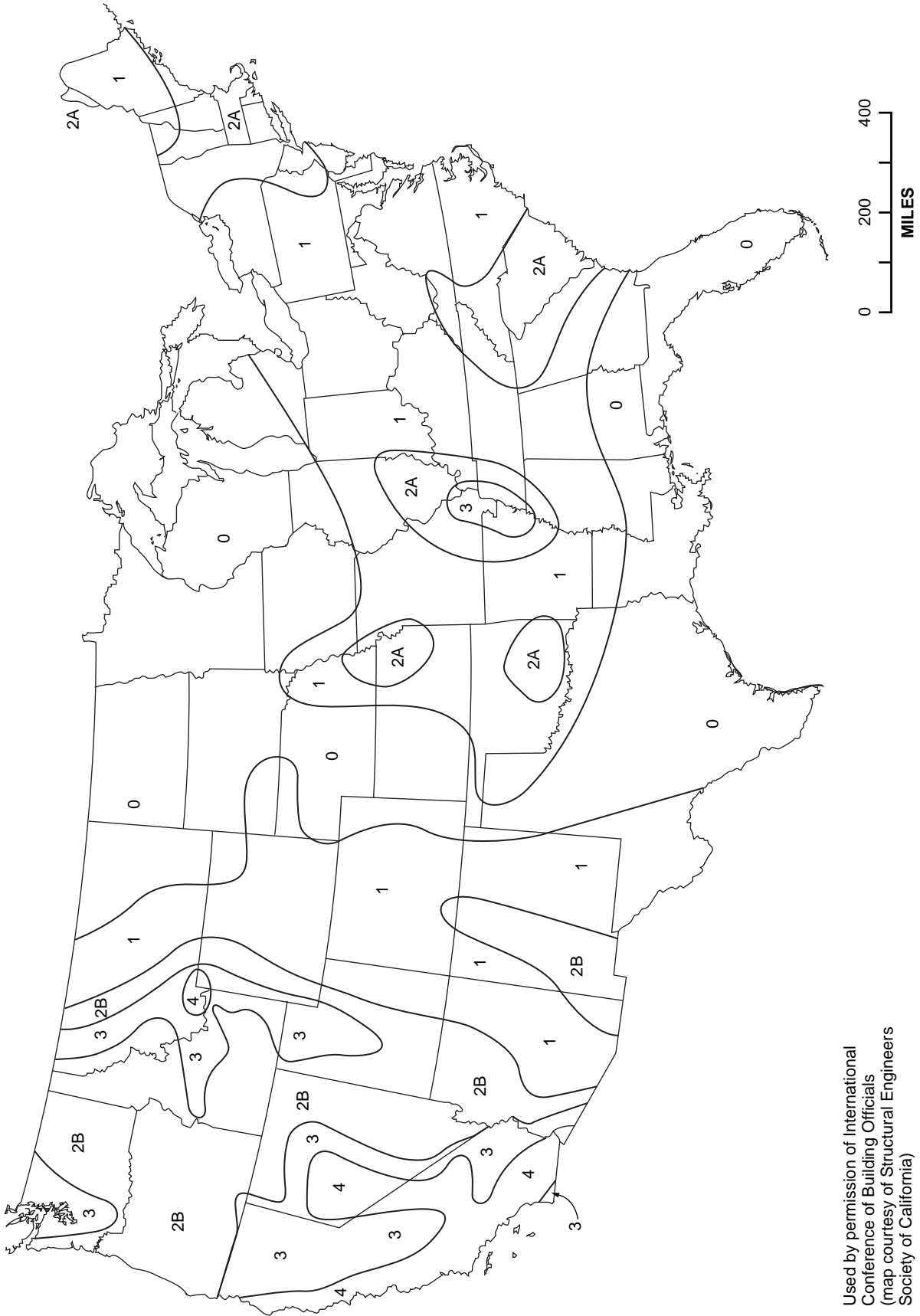

Used by permission of International
Conference of Building Officials
(map courtesy of Structural Engineers
Society of California)

Note: For Canadian seismic zones, refer to the National Building Code of Canada, Supp. No. 1.

Figure L-1—Seismic Zone Map

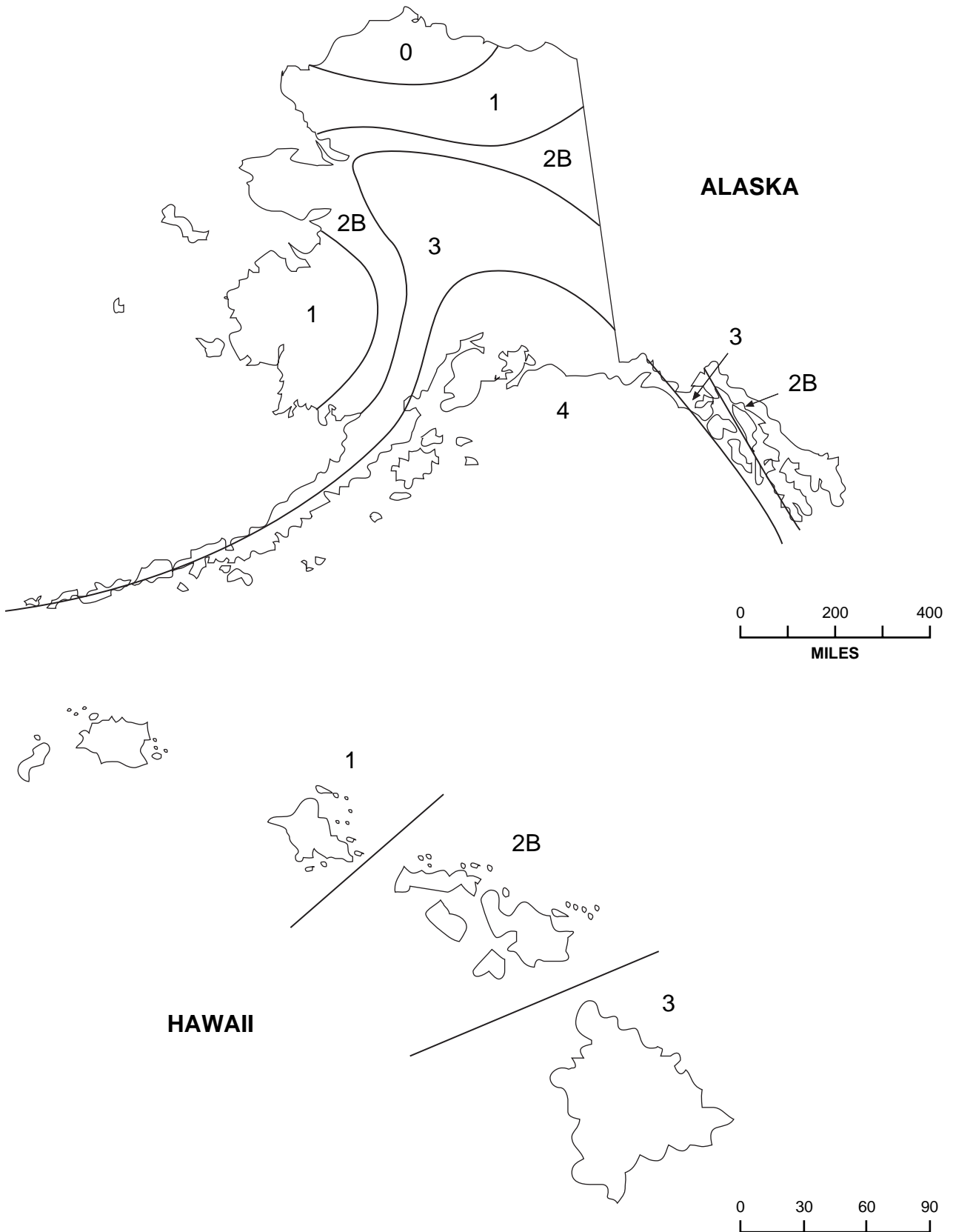

Figure L-1-Part 2—Seismic Zone Map

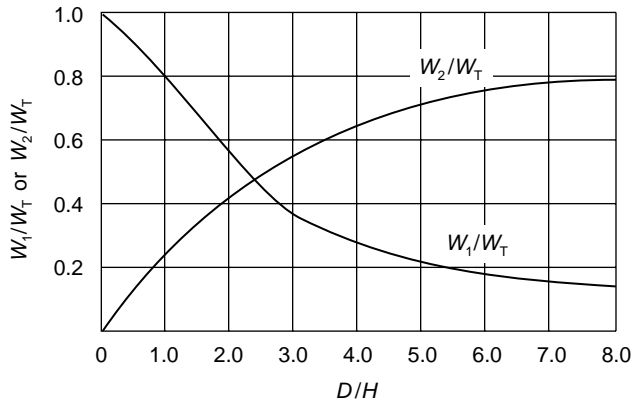

Figure L-2—Curves for Obtaining Factors W_1/W_T and W_2/W_T for the Ratio D/H

When T is greater than 4.5,

$$C_2 = \frac{3.375S}{T^2}$$

where

- S = site coefficient from Table L-3,
- T = natural period of first mode sloshing, in seconds. T may be determined using the following equation: $T = kD^{0.5}$,
- k = factor obtained from Figure L-4 for the ratio D/H .

L.3.3.3 Alternatively, by agreement between the purchaser and the manufacturer, the lateral force factors determined by the products ZIC_1 and ZIC_2 may be determined from response spectra established for the specific site of the tank and furnished by the purchaser. In no case shall the lateral force factor ZIC_1 be less than that determined in accordance with L.3.1 and L.3.3.1.

L.3.3.4 The response spectra for a specific site shall be established by considering the active faults within the region, the types of faults, the magnitude of the earthquake that could be generated by each fault, the regional seismic activity rate, the proximity of the site to the potential source faults, the attenuation of the ground motion between the faults and the site, and the soil conditions at the site. The spectrum for the factor ZIC_1 shall be established for a damping coefficient of 2% of critical. Scaling the response spectrum to account for the reserve capacity of the tank is permissible. The acceptable reserve capacity shall be specified by the purchaser. The reserve capacity may be determined by considering shaking table tests, field observations that demonstrate tank response to actual earthquakes, and the ductility of the structure.

L.3.3.5 The spectrum for the factor ZIC_2 shall correspond to the spectrum for ZIC_1 except that it should be modified for

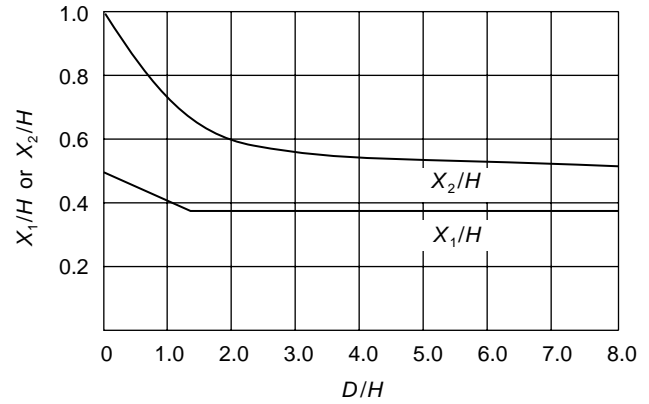

Figure L-3—Curves for Obtaining Factors X_1/H and X_2/H for the Ratio D/H

a damping coefficient of 0.5% of critical. Unless the maximum spectral acceleration is used, the fundamental period of the tank with its contents shall be taken into account in determining the factor ZIC_1 from the spectrum.

L.4 Resistance to Overturning

L.4.1 Resistance to the overturning moment at the bottom of the shell may be provided by the weight of the tank shell and the weight of a portion of the tank contents adjacent to the shell for unanchored tanks or by anchorage of the tank shell. For unanchored tanks, the portion of the contents that may be utilized to resist overturning depends on the width of the bottom plate under the shell that lifts off the foundation. The portion may be determined using the following equation:

$$W_L = 7.9t_b\sqrt{F_{by}GH}$$

where

- W_L = maximum weight of the tank contents that may be utilized to resist the shell overturning moment, in lbs/ft of shell circumference; W_L shall not exceed $1.25GHD$,
- t_b = thickness of bottom plate under the shell, in in.,

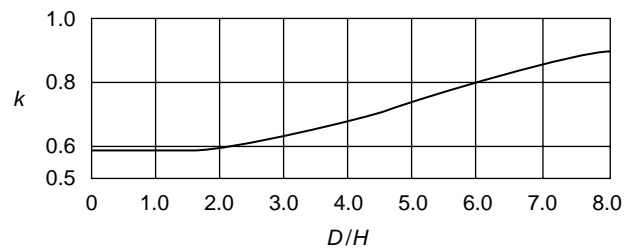

Figure L-4—Curve for Obtaining Factor k for the Ratio D/H

Table L-3—Site Coefficients

Type	Description	S Factor
S_1	A soil profile with either: (a) A rock-like material characterized by a shear-wave velocity greater than 2,500 ft per second or by other suitable means of classification, or (b) Stiff or dense soil condition where the soil depth is less than 200 ft	1.0
S_2	A soil profile with dense or stiff soil conditions, where the soil depth exceeds 200 ft	1.2
S_3	A soil profile 70 ft or more in depth and containing more than 20 ft of soft to medium stiff clay but not more than 40 ft of soft clay.	1.5
S_4	A soil profile containing more than 40 ft of soft clay characterized by a shear wave velocity less than 500 ft per second.	2.0

Note: ¹The site factor shall be established from properly substantiated geotechnical data. In locations where the soil properties are not known in sufficient detail to determine the soil profile type, soil profile S_3 shall be used. Soil profile S_4 need not be assumed unless the building official determines that soil profile S_4 may be present at the site, or in the event that soil profile S_4 is established by geotechnical data.

F_{by} = minimum specified yield strength of the bottom plate under the shell, in lbf/in.² gauge,

G = design specific gravity of the product to be stored, as specified by the purchaser.

L.4.2 The thickness of the bottom plate under the shell, t_b , shall not exceed the thickness of the bottom shell course or $1/4$ in., whichever is greater. Where the bottom plate under the shell is thicker than the remainder of the bottom, the width of the thicker plate under the shell, in ft, measured radially inward from the shell, shall be greater than or equal to the value obtained from the following equation:

$$0.0274 \frac{W_L}{GH}$$

L.5 Shell Compression

L.5.1 UNANCHORED TANKS

The maximum longitudinal compressive force at the bottom of the shell may be determined as follows:

When $M/[D_2(w_t + w_L)]$ is equal to or less than 0.785,

$$b = W_t + \frac{1.273M}{D^2}$$

When $M/[D_2(w_t + w_L)]$ is greater than 0.785 but less than or equal to 1.5, b may be computed from the value of the following parameter obtained from Figure L-5:

$$\frac{b + W_L}{W_t + W_L}$$

When $1.5 < M/[D_2(w_t + w_L)] \leq 1.57$,

$$\frac{b + W_L}{W_t + W_L} = \frac{1.490}{\left[1 - \frac{0.637M}{D^2(W_t + W_L)}\right]^{0.5}}$$

When $M/[D_2(W_t + W_L)]$ is greater than 1.57 or when $b/12t$ exceeds F_a (see L.5.3), the tank is structurally unstable. One of the following measures must then be taken:

- Increase the thickness of the bottom plate under the shell, t_b , to increase W_L if the limitations of L.4.1 and L.4.2 are not exceeded.
- Increase the shell thickness, t .
- Change the proportions of the tank to increase the diameter and reduce the height.
- Anchor the tank according to the provisions of L.6.

The variables used in the previous equations are defined as follows:

b = maximum longitudinal shell compressive force, in lbs/ft of shell circumference,

W_t = weight of the tank shell and the portion of the fixed roof and insulation, if any, supported by the shell, in lbs/ft of shell circumference.

L.5.2 ANCHORED TANKS

The maximum longitudinal compressive force at the bottom of the shell may be determined using the following equation:

$$b = W_t + \frac{1.273M}{D^2}$$

L.5.3 MAXIMUM ALLOWABLE SHELL COMPRESSION

The maximum longitudinal compressive stress in the shell, $b/12t$, shall not exceed the maximum allowable stress, F_a , determined by the following formulas for F_a that take into account the effect of internal pressure due to the liquid contents and need not be further reduced to satisfy 5.5.4.5, 5.5.4.6 and Figure 5-1:

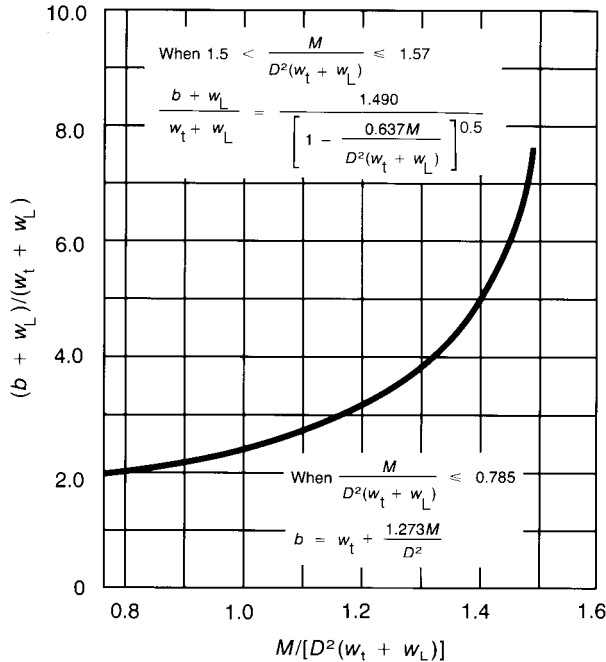

Figure L-5—Curve for Obtaining the Value of *b* when $M/[D^2(w_t + w_L)]$ Exceeds 0.785

When GHD^2/t^2 is greater than or equal to 10^6 ,

$$F_a = \frac{10^6 t}{D}$$

When GHD^2/t^2 is less than 10^6 ,

$$F_a = \frac{10^6 t}{2.5D} + 600\sqrt{GH}$$

where

t = thickness of the bottom shell course, excluding corrosion allowance, in.,

F_a = maximum allowable longitudinal compressive stress in the shell, in lbf/in.². In no case shall the value of *F_a* exceed $0.5F_{ty}$,

F_{ty} = minimum specified yield strength of the bottom shell course, in lbf/in.².

L.5.4 UPPER SHELL COURSES

If the thickness of the lower shell course calculated to resist the seismic overturning moment is great than the thickness required for hydrostatic pressure, both excluding any corrosion allowance, then the calculated thickness of each upper shell course for hydrostatic pressure shall be increased in the same proportion unless a special analysis is made to deter-

mine the seismic overturning moment and corresponding stresses at the bottom of each upper shell course.

L.6 Anchorage of Tanks

When anchorage is considered necessary (usually by combined internal pressure and wind), it shall be designed to provide for at least the following minimum seismic anchorage resistance in lbs/ft of shell:

$$\frac{1.273M}{D^2} - w_t$$

The stresses due to anchor forces in the tank shell at the points where the anchors are attached shall be investigated.

L.7 Piping

Suitable flexibility shall be provided in the vertical direction for all piping attached to the shell or bottom of the tank. On unanchored tanks that are subject to bottom uplift, piping connected to the bottom shall be free to lift with the bottom or shall be located so that the horizontal distance measured from the shell to the edge of the connecting reinforcement is equal to the width of the bottom hold-down as calculated in L.4.2, plus 12 in.

L.8 Additional Consideration

L.8.1 The purchaser shall specify if freeboard is desired to minimize or prevent overflow and damage to the roof and upper shell due to sloshing of the liquid contents. The theoretical height of the sloshing wave may be determined using the following equation:

$$d = 1.124ZIC_2T^2 \tanh \left[4.77 \left(\frac{H}{D} \right)^{0.5} \right]$$

where

d = height of the sloshing wave, in ft. A minimum of 1 ft should be added to allow for liquid run-up on the tank shell.

L.8.2 The base of the columns that support the roof shall be restrained to prevent lateral movement during earthquakes. When specified by the purchase, the columns shall be designed to resist the forces caused by the sloshing of the liquid contents.

L.8.3 The additional vertical forces at the shell due to the seismic overturning moment shall be considered in the design of the tank foundation.

L.8.4 Unless otherwise required, tanks that may be subject to sliding due to earthquake may use a sliding friction of 0.40 times the force against the tank bottom.

**For Committee
Use Only**

APPENDIX M—RECOMMENDED SCOPE OF THE MANUFACTURER'S REPORT

M.1 General

This appendix does not set down rigid rules for the preparation of the manufacturer's report. The extent of the information contained in the report—with the accompanying supplementary sketches, graphs of tests, and possibly special items required by the purchaser, as shown on purchase orders—cannot possibly be listed here (see 7.13).

M.2 Shop Stress Relief

When parts of the structure are shop assemblies, which are stress relieved as called for in 5.25 and 6.18, the plans shall indicate this in the customary general notes.

M.3 Field Repairs or Changes

When more than minor repairs or changes and/or additions are made to the structure in the field for any reason, it is assumed that both the manufacturer and the purchaser will

want to have a record of these repairs or changes attached to the manufacturer's report.

M.4 Tank Certification

A certificate shall be supplied for each tank. This practice is intended to simplify keeping the records of future inspection in separate files for convenience. When a group of tanks is being constructed on one order and in one general location some specific form of reporting other than a manufacturer's report may be preferred by both parties. It would seem desirable that the details on each contract be settled when the purchase order is placed; if they are not covered in the proposal, then they shall be given as information in the inquiry.

M.5 Tank Certificate Wording

The suggested format and wording for a certificate is as follows:

WE CERTIFY that the design, materials, construction and workmanship on this low-pressure tank conforms to the requirements of API Std 620, *Design and Construction of Large, Welded, Low-Pressure Storage Tanks*.

Date _____ 20____ Signed _____ by _____

I have inspected the tank described in this manufacturer's report dated _____, and state that to the best of my knowledge, the manufacturer has constructed this tank in accordance with the applicable sections of API Std 620. The tank was inspected and subjected to a test of _____ lbf/in.² gauge.

Date _____ 20____ Signed _____ by _____

**For Committee
Use Only**

APPENDIX N—INSTALLATION OF PRESSURE-RELIEVING DEVICES

N.1 General

Pressure-relieving devices shall be installed so that they are readily accessible for inspection and removable for repairs. The practices suggested in API RP 520, Part II, for the installation of ASME approved safety relief valves shall generally apply, with due consideration given to the difference in pressure ranges.

N.2 Location

If the relieving devices for gases are not located on the roof, they shall be installed on the piping connected to the vapor space, if any, as close to the tank as is practicable; if the relieving devices are vented to atmosphere, they shall be at a sufficient height to prevent chance ignition (see API Std 2000).

N.3 Size of Tank Opening

The opening from the tank leading to the relieving device shall have a size at least as large as the inlet nominal pipe size of the relieving device.

N.4 Discharge Pipes

N.4.1 When a discharge pipe is used on the outlet side of such relieving devices, its area shall be not less than the area of the valve outlet, or if a single pipe provides for discharge from several relief devices, its area shall be not less than the aggregate area of the valve outlets. The discharge pipe shall

be fitted with an open drain to prevent water or other liquids from lodging in the discharge side of the valves.

N.4.2 Discharge pipes shall be supported so that no undue stress is placed on the valve body. Open discharges shall be placed and oriented so that the outflow is directed away from the tank and will not create a hazard over walkways, stairways, or operating platforms.

N.5 Security Against Damage

The assemblies of relieving devices shall be secured against damage in service, the effects of storms, or mishandling. Access ladders and platforms that meet plant safety rules are suggested.

N.6 Vacuum-Relieving Devices

A vacuum-relieving device, when used, shall be as direct in inflow as possible with no pockets where moisture can collect, and it shall have no piping except a weather hood ahead of the inlet. An adequate vacuum-air inlet shall also be provided.

N.7 Stop Valves

Stop valves, if used between the relieving devices and the tank to help service these devices, shall be locked or sealed open, and an authorized person shall be present if this condition is changed. If the tank is in use, the authorized person shall remain there until the locked or sealed-open position of the affected relieving devices is restored.

**For Committee
Use Only**

APPENDIX O—SUGGESTED PRACTICE REGARDING INSTALLATION OF LOW-PRESSURE STORAGE TANKS

O.1 Introduction

The practices recommended in this appendix are intended for general guidance only. They are not essentially a part of the construction rules for low-pressure storage tanks because in most instances sound engineering principles for safe and efficient operation will dictate the proper procedure for each installation.

O.2 Marking

When the owner or operator provides an additional plate to show the current operating pressure range in a tank, the plate shall be securely attached, preferably near the manufacturer's nameplate (showing the markings required by these rules). Such markings shall not be covered by the additional plate.

O.3 Access

All openings and accessories for tanks constructed according to this standard shall be installed so that any periodic inspections required can be readily made.

O.4 Corrosion

When a tank bottom rests directly on the ground, a survey shall be made to establish the need for cathodic protection.

O.5 Drainage

All tanks in which water might accumulate under the hydrocarbon contents shall be provided with adequate drains that are suitably protected from freezing.

O.6 Fireproofing

O.6.1 Although general fire prevention and fire protection measures are expected to be fully covered by other safety codes, tanks constructed according to these rules, which may be subject to fire exposure resulting from any cause, shall have their supports suitably fireproofed.

O.6.2 Special consideration shall be given to provisions for ample drainage facilities for accidental spills or leakage of flammable contents from such tanks or adjacent piping and other equipment if the contents may become ignited.

O.6.3 Subject to special considerations in isolated locations, tanks in which flammable liquid products are stored at temperatures well above their average boiling point shall be suitably fireproofed or otherwise protected.

**For Committee
Use Only**

APPENDIX P—NDE AND TESTING REQUIREMENTS SUMMARY

Process	Welds for which the Inspection and Testing is Required	Reference Section
Air Test	Through tell-tale holes, all welds of nozzles with single thickness reinforcing plates, saddle flanges, or integral reinforcing pads. Does not include nozzles on the underside of tank bottoms or reinforcements that are too narrow.	5.16.10, 7.18.2.3
Air Test	Completed tank	7.18.2.6
Air Test	Roofs of tanks not designed for liquid loading.	7.18.3.1
Air Test	Appendix R tanks: Shell-to-bottom welds which are not complete penetration.	R8.2.3
Air Test	Appendix R tanks: Completed tank.	R.8.4
Air Test	Appendix R tanks: Outer tank of a double wall refrigerated tank.	R.9
Air Test	Appendix Q: The shell-to-bottom welds that are not full penetration.	Q.8.2.2
Air Test	Appendix Q: Vapor space above hydrostatic test level when the tank is subjected to pneumatic pressure.	Q.8.5.1 & Q.8.5.4
Hydro	Shell only if the roof is not designed for liquid loading.	7.18.3.1
Hydro	Complete tank including the roof if so designed.	7.18.4.1
Hydro	Appendix R tanks.	R.8
Hydro	Appendix Q:	Q.8.1.1
MT	Flush type shell connections: Nozzle-to-tank shell, Repad welds, shell-to-bottom reinforcing pad welds on the root pass, every 1/2 in. of deposited weld, and completed weld.	5.27.11
MT	Welds attaching nozzles, manways, and clean out openings unless given a liquid penetrant test.	7.18.2.2
MT	Appendix R carbon steel tanks: all butt welds not completely radiographed, cylindrical wall to bottom annular plate weld, all welds of openings that are not completely radiographed (includes progressive MT) attachment welds to primary components, and the second layer of weld on joints with permanent backing strips.	R.7.5
MT	Permanent and temporary attachments if not examined by PT.	7.16.3, R.7.8
PT	Appendix R stainless steel tanks: all butt welds not completely radiographed, cylinder wall to bottom annular plate weld, all welds of openings that are not completely radiographed (includes progressive PT) attachment welds to primary components, and the second layer of weld on joints with permanent backing strips.	R.7.5
PT	Welds attaching nozzles, manways, and clean out openings instead of MT if approved. Not for Appendix Q tanks.	7.16.4
PT	Appendix Q: All longitudinal and circumferential butt-welds not completely radiographed.	Q.7.5.a
PT	Appendix Q: Cylindrical wall-to-annular plate welds.	Q.7.5.b
PT	Appendix Q: Opening welds that are not radiographed. PT the root pass and every 1/2 in. of deposited weld metal.	Q.7.5.c
PT	Appendix Q: Attachment welds of non-pressure parts to primary components.	Q.7.5.d
PT	Appendix Q: The second pass of joints on which backing strips are to remain.	Q.7.5.e
PT	Appendix Q: Base metal repairs for erection lug removal areas on primary components.	Q.7.9

Process	Welds for which the Inspection and Testing is Required	Reference Section
RT	100% butt welds of joints with plate thicker than 1.25 in. and tension stress greater than 0.1 times the specified minimum tensile stress of the material and where required by joint efficiency.	5.26.2, 5.26.3
RT	Spot examination for all butt-welded main joints that are not 100% radiographed except for roof joints exempted by Table 5-2, tank bottoms fully supported, and components designed for compressive stress only (5.26.4).	7.17.2.1
RT	Flush-type shell connections.	5.27.11
RT	Appendix Q: 100% of butt-welds with operating stress greater than 0.1 times plate tensile strength.	Q.7.6.1
RT	Appendix Q: Spot RT butt-welds with operating stress less than or equal to 0.1 times the plate tensile strength.	Q.7.6.2
RT	Appendix Q: 100% of butt-welds around thickened insert plates.	Q.7.6.3
RT	Appendix Q: All three plate butt joints except flat bottoms uniformly supported.	Q.7.6.4
RT	Appendix Q: 25% of butt-welded annular plate radial joints shall have 6-in. radiographs taken at the outside of the selected joints.	Q.7.6.5
RT	Appendix Q: 25% of butt-welded compression bar radial joints shall have 6-in. radiographs except as required by 5.26.3.3.	Q.7.6.6
RT	Appendix Q: 100% of longitudinal butt welds in pipes and pipe fittings containing liquids within the limitations of 1.3.2 except for pipe 12 in. diameter or less that has been welded without filler metal and has been hydrotested.	Q.7.7.2
RT	Appendix Q: 100% of longitudinal butt welds in pipes and pipe fittings containing vapor within the limitations of 1.3.2 except for pipe 18 in. diameter or less that has been welded without filler metal and has been hydrotested.	Q.7.7.3
RT	Appendix Q: 30% of all circumferential welded pipe joints.	Q.7.7.4
RT	Appendix Q: 100% of butt-welded joints used to fabricate tank fittings.	Q.7.7.5
RT	Appendix R tanks: Primary-component butt welds.	R.7.6
RT	Appendix R tanks: Butt welds in piping.	R.7.7
VB	Bottom Welds unless tested by tracer gas.	7.18.2.4
VB	Appendix R tanks: all bottom welds, full penetration shell-to-bottom welds, and fillet welds around bottom openings that do not receive repad pressure test.	R.8.2.1, R.8.2.2, R.8.2.5
VB	Appendix Q: All bottom welds and full penetration joints between the shell and bottom.	Q.8.2.1
VB	Appendix Q: Welds above hydro test level when the inner tank pneumatic pressure is equalized on both sides.	Q.8.2.4
VB	Appendix Q: Attachment fillets around bottom openings that cannot be tested by air pressure behind the repads.	Q.8.2.5
VE	Tack welds left in place.	6.9.1.4
VE	All welds.	7.15.5
VE	Shell-plate butt welds.	7.16.1
VE	Appendix Q: Base metal repairs for erection lug removal areas on secondary components.	7.16.1
VE	Welds attaching nozzles, manways, and clean out openings.	7.16.4

Process	Welds for which the Inspection and Testing is Required	Reference Section
Definitions:		
	MT= Magnetic Particle Examination PT = Liquid Penetrant Examination Pen Oil = Penetrating Oil Test RT = Radiographic Testing VB = Vacuum Box Testing VE = Visual Examination	
Acceptance Standard:		
	MT: ASME Section VIII, Appendix 6, Paragraphs 6-3, 6-4, and 6-5 PT: ASME Section VIII, Appendix 8, Paragraphs 8-3, 8-4, and 8-5 VE: API 620, Sections 7.15.5.2 and 7.15.5.3 RT: ASME Section VIII, Paragraph UW-51(b)	
Examiner Qualifications:		
	MT: API 620, Section 7.15.2.3 PT: API 620, Section 7.15.4.3 VE: none VB: none RT: ASNT Level II or III	
Procedure Requirements:		
	MT: ASME Section V, Article 1, T-150 PT: ASME Section V, Article 6 VE: none VB: none RT: A procedure is not required. However, the examination method must comply with ASME Section V, Article 2.	

**For Committee
Use Only**

APPENDIX Q—LOW-PRESSURE STORAGE TANKS FOR LIQUEFIED HYDROCARBON GASES

Q.1 Scope

Q.1.1 GENERAL

The provisions in this appendix form a guide for the materials, design, and fabrication of tanks to be used for the storage of liquefied ethane, ethylene, and methane.

The requirements for a basic API Std 620 tank are superseded by any requirements of this appendix. All other requirements for an API Std 620 tank shall apply.

A refrigerated tank may be a single-wall insulated tank or a double-wall tank that consists of an inner tank for storing the refrigerated liquid and an outer tank that encloses an insulating space around the inner tank. A double-wall tank is a composite tank; the outer tank is not required to contain the product of the inner tank. In a double-wall tank, differences in materials, design, and testing exist between the inner and outer tanks.

Q.1.2 PRESSURE RANGE

The provisions in this appendix apply to all design pressures within the scope of this standard.

Q.1.3 TEMPERATURE

The provisions in this appendix apply to design metal temperatures encountered in the storage of liquefied hydrocarbon gases, but they do not apply to temperatures lower than -270°F .

Q.1.4 PRIMARY COMPONENTS

Q.1.4.1 In general, primary components include those components that may be stressed to a significant level, those whose failure would permit leakage of the liquid being stored, those exposed to a refrigerated temperature between -60°F and -270°F , and those that are subject to thermal shock. The primary components shall include, but will not be limited to, the following parts of a single-wall tank or of the inner tank in a double-wall tank: shell plates; bottom plates; roof plates; knuckle plates; compression rings; shell stiffeners; and manways and nozzles including reinforcement, shell anchors, pipe, tubing, forgings, and bolting.

Q.1.4.2 When roof plates, knuckle plates, compression rings, and manways and nozzles including reinforcement are primarily subjected to atmospheric temperature, the rules in Q.2.3 shall govern.

Q.1.5 SECONDARY COMPONENTS

In general, secondary components include those components that will not be stressed to a significant level by the refrigerated liquid, those whose failure will not result in leakage of the liquid being stored, those exposed to product vapors, and those that have a design metal temperature of -60°F or higher.

Q.2 Materials

The materials requirements are based on the storage of refrigerated products at the design metal temperature.

Q.2.1 PRIMARY COMPONENTS

Materials for primary components shall comply with the requirements of Q.2.2 and Table Q-1.

Q.2.2 IMPACT TEST REQUIREMENTS FOR PRIMARY COMPONENTS

Q.2.2.1 All primary components of 9% or 5% nickel steel shall be impact tested in accordance with Q.2.2.2 through Q.2.2.4. Impact testing is not required for primary components of austenitic stainless steel, nickel alloy, and aluminum materials. Welds in high-alloy (austenitic) stainless steel shall be impact tested if required by Q.6.3.

Q.2.2.2 Impact testing of plates, including structural members made of plate, shall comply with the following:

- Impact test specimens shall be taken transverse to the direction of final plate rolling.
- Charpy V-notch specimens shall be cooled to a temperature of -320°F for A 353, A 553, and A 645 steels for impact testing.

Note: This temperature is selected to be consistent with the standard requirements of the ASTM specifications. The temperature of -320°F also provides a convenient and safe medium (liquid nitrogen) for cooling; for testing techniques, see ASTM A 370. For ethylene and ethane service, the test temperature of -220°F is also acceptable.

- The transverse Charpy V-notch impact values shall conform to Table Q-2.
- Each test shall consist of three specimens, and each specimen shall have a lateral expansion opposite the notch of not less than 0.015 in. (15 mils) as required by ASTM A 353, A 553, and A 645.
- Retests shall be in accordance with ASTM A 353, A 553, and A 645.

Table Q-1—ASTM Materials for Primary Components

Plates and Structural Members	Piping and Tubing	Forgings	Bolting
A 353 (See note 1)	A 333, Grade 8 (see note 2) B 444 (UNS-N06625), Gr. 1	A522 —	— —
A 553, Type 1 (see note 1)	A 334, Grade 8 (see note 2) B 444 (UNS-N06625), Gr. 2	— —	— —
A 645	B 619 (UNS-N10276)(see note 3) B 622 (UNS-N10276)	— —	— —
A 240, Type 304 A 240, Type 304L — — —	A 213, Grade TP 304 A 213, Grade TP 304 L A 312, Grade TP 304 (see note 3) A 313, Grade TP 304L (see note 3) A 358, Grade 304, Class 1 (see note 4)	A 182, Grade F 304 A 182, Grade F 304L — — —	A 320, Grades B8, B8C, B8M and B8T — — —
B 209, Alloy 3003-0 (see note 5) B 209, Alloy 5052-0 (see note 5) B 209, Alloy 5083-0 (see note 5) B 209, Alloy 5086-0 (see note 5) B 209, Alloy 5154-0 (see note 5)	B 210, Alloy 3003-0 B 210, Alloy 3003-H112 B 210, Alloy 5052-0 B 210, Alloy 5086-0 B 210, Alloy 5154-0	B 247, Alloy 3003-H112 B 247, Alloy 5083-H112Mod — — —	B211, Alloy 6061-T6 — — — —
B 209, Alloy 5456-0 (see note 5) B 221, Alloy 6061-T4 and T6 B 308, Alloy 6061-T2 and T6 — —	B 241, Alloy 5052-0 B 241, Alloy 5083-0 B 241, Alloy 5086-0 B 241, Alloy 5454-0 B 241, Alloy 5456-0	— — — — —	— — — — —

Notes:

1. When pressure parts are made of ASTM A 353 or A 553 material or nickel alloy, pipe flanges or pipe may be austenitic stainless steel of a type that cannot be hardened by heat treatment. Pipe flanges or pipe may be welded to nozzle necks of the pressure part material if the butt weld is located more than a distance equal to the r , measured from the face of the reinforcement where r = inside radius of the nozzle neck, in in., and t = thickness of the nozzle neck, in in. The design of the nozzle neck shall be based on the allowable stress value of weaker material.

2. Seamless piping and tubing only.

3. Welded pipe shall be welded from the outside only by the tungsten-arc insert gas-shielded (TG) process without the addition of filler metal and shall be hydrostatically tested.

4. Impact test of welds shall be made for the welding procedure when required by Q.6.3.

5. ASTM B 221 structural sections are also permitted.

Q.2.2.3 Impact testing of structural members shall comply with the following:

a. For each different shape in each heat-treatment lot, one set of three specimens taken in the longitudinal direction from the thickest part of each shape shall be tested. If the heat-treatment lot consists of shapes from several ingots, tests shall be conducted on the various shapes of each ingot.

b. Charpy V-notch specimens shall be cooled to a temperature of -320°F (see Q.2.2.2, item b) for A 353, A 553, and A 645 steels for impact testing.

c. The longitudinal Charpy V-notch impact values shall conform to Table Q-2.

d. Each test shall consist of three specimens, and each specimen shall have a lateral expansion opposite the notch of not

less than 0.015 in. (15 ml) as required by ASTM A 353, A 553, and A 645.

e. Retests shall be in accordance with ASTM A 353, A 553, and A 645.

Q.2.2.4 Impact testing of forgings, piping, and tubing shall comply with the following:

a. Impact test specimens shall be taken from each heat included in any heat-treatment lot.

b. Charpy V-notch specimens shall be cooled to a temperature of -320°F (see Q.2.2.2, item b) for A 522, A 333 (Grade 8), and A 334 (Grade 8) steels for impact testing.

c. The minimum Charpy V-notch impact values shall conform to the longitudinal values in Table Q-2.

Table Q-2—Charpy V-Notch Impact Values^a

04

04

04

Size of Specimen (mm)	Transverse		Longitudinal	
	Value Required for Acceptance ^b (ft-lb)	Minimum Value Without Requiring Retest ^c (ft-lb)	Value Required for Acceptance ^b (ft-lb)	Minimum Value Without Requiring Retest ^c (ft-lb)
10 × 10.00	20	16	25	20
10 × 7.50	15	12	19	16
10 × 6.67	13	10	17	13
10 × 5.00	10	8	13	10
10 × 3.33	7	5	8	7
10 × 2.50	5	4	6	5

Notes:

^aWhen the alternate flaw acceptance criteria of Table U-2 are applied, the higher impact values of Table U-3 are required for plates.^bAverage of three specimens.^cOnly one specimen of a set.

d. Each test shall consist of three specimens, and each specimen shall have a lateral expansion opposite the notch of not less than 0.015 in. (15 ml) as required by ASTM A 522, A 333, (Grade 8), and A 334 (Grade 8).

e. Retests shall be in accordance with ASTM A 522, A 333 (Grade 8), and A 334 (Grade 8).

Q.2.3 SECONDARY COMPONENTS

Materials for secondary components shall comply with Q.2.3.1 and Q.2.3.2.

Q.2.3.1 Material for the outer tank that contains the vaporized liquefied gas but is primarily subjected to atmospheric temperatures may conform to one of the following:

- Table 4-1 for design metal temperatures down to -35°F (lowest one-day mean ambient temperature of -35°F) without impact tests unless they are required by Table 4-1 or by the purchaser.
- Table R-4 for design metal temperatures down to -60°F without impact tests unless they are required by Table R-4 or by the purchaser.
- Paragraph Q.2.1 without impact tests unless they are specified by the purchaser.
- If approved by the purchaser, the material may be selected according to the requirements of 4.2.2.

Q.2.3.2 Material for the outer tank that does not contain the vaporized liquefied gas may conform to any of the approved materials listed in Table 4-1. Consideration of the design metal temperature is not required if the actual stress in the outer tank does not exceed one-half the allowable tensile design stress for the material.

Q.2.4 STRUCTURAL SHAPES

Structural shapes of 9% and 5% nickel steel may be furnished to the chemical and physical requirements of ASTM A 353, A 553, or A 645. Physical tests shall be in accordance with the requirements of ASTM A 6.

Q.2.5 PIPING, TUBING, AND FORGINGS

Q.2.5.1 Material used for piping, tubing, and forgings shall be compatible in welding and strength with the tank shell material. In addition to the specific requirements of this appendix, all piping within the limitations of 1.3.2 shall fulfill the minimum requirements of ASME B31.3.

Q.2.5.2 Nickel alloy material B 444 (UNS-N06625), B 622 and B 619 (UNS-N10276) in Table Q-1 may be used for piping and tubing as a substitute for A 333, Grade 8 or A 334, Grade 8 for 9% In (A 353, A 553) and 5% In (A 645) storage tanks, providing these materials meet the applicable requirements in this appendix and are not used for reinforcement.

Q.3 Design

Q.3.1 WEIGHT OF LIQUID STORED

The weight of liquid stored shall be assumed to be the maximum weight per ft^3 of the specified liquid within the range of operating temperatures, but in no case shall the assumed minimum weight be less than 29.3 lb/ft^3 for methane, 34.21 lb/ft^3 for ethane, and 35.5 lb/ft^3 for ethylene.

Q.3.2 DESIGN METAL TEMPERATURE

The design metal temperature of each component exposed to the liquid or vapor being stored shall be the lower of the temperatures specified as follows:

- a. The design metal temperature of the components of the single-wall tank or the inner tank of a double-wall tank shall be the minimum temperature to which the tank contents shall be refrigerated, including the effect of subcooling at reduced pressure.
- b. The design metal temperature of the secondary components shall be the lower of the minimum atmospheric temperature conditions (see 4.2.1) and the vaporized liquefied gas temperature, if the components are in contact with the vapor. The effectiveness of the insulation in keeping the metal temperature above the minimum atmospheric or refrigerated temperature shall be considered.

Q.3.3 ALLOWABLE DESIGN STRESSES

Q.3.3.1 The maximum allowable design stresses for the materials outlined in Q.2.1 shall be in accordance with Table Q-3.

Q.3.3.2 The values for the allowable design tensile stress given in Table Q-3 for materials other than bolting steel are the lesser of (a) 33¹/₃% of the specified minimum ultimate tensile strength for the material or (b) 66²/₃% of the specified minimum yield strength, but they are 75% of the specified minimum yield strength for the stainless steel, nickel alloy, and aluminum materials. Allowable test stresses are based on the limitation of Q.8.1.3. If the weld filler metal has an unspecified yield strength, or specified minimum yield or ultimate tensile strength below the specified minimums for the base metal, the base metal allowable stresses shall be based on the weld metal and heat-affected zone strengths as determined by Q.6.1. Where welding procedure qualification testing shows the deposited weld metal and heat affected zone strengths, the base metal strengths shall be used, except for Table Q-3, notes (a) and (b).

Q.3.3.3 Where plates or structural members are used as anchor bars for resisting the shell uplift, the allowable design and test stresses for the material shall be used for the design and overload test conditions, respectively.

Q.3.3.4 Allowable compressive stresses shall be in accordance with 5.5.4 except that for aluminum alloy plate the allowable compressive stresses shall be reduced by the ratio of the modulus of compressive elasticity to 29,000 for values of $(t - c)/R$ less than 0.0175 and by the ratio of the minimum yield strength for the aluminum alloy in question to 30,000 for values of $(t - c)/R$ equal to or greater than 0.0175 (see 5.5.2 for definitions). In all other equations in this standard where yield strength or modulus of elasticity is used, such as

Equations 27 and 28, similar corrections shall be made for aluminum alloys.

Q.3.3.5 The maximum allowable tensile stress for design loadings combined with wind or earthquake loadings shall not exceed 90% of the minimum specified yield strength for stainless steel or aluminum.

Q.3.3.6 For allowable stresses in aluminum alloy structural members and minimum modulus of compressive elasticity, see the Aluminum Association "Specifications for Aluminum Structures—Allowable Stress Design and Commentary." Materials shall be those permitted in Table Q-1.

Q.3.4 BOTTOM PLATES

Q.3.4.1 The tank shell that contains the liquid shall have butt-welded annular bottom plates with a radial width that provides at least 24 in. between the inside of the shell and any lap-welded joint in the remainder of the bottom and at least a 2-in. projection outside the shell. A greater radial width (L_{min}) of annular plate is required when calculated by the following equations:

For steel,

$$L_{min} = \frac{390t_b}{\sqrt{(H)(G)}} \text{ in.}$$

For aluminum,

$$L_{min} = \frac{255t_b}{\sqrt{(H)(G)}} \text{ in.}$$

where

t_b = nominal thickness of the annular plate, in in.,

H = maximum height of the liquid, in ft,

G = design specific gravity of the liquid to be stored.

Q.3.4.2 The thickness of the annular bottom plates shall be in accordance with Table Q-4 (for steel or aluminum, as applicable). The thicknesses shown are minimums.

Q.3.4.3 The ring of annual plates shall have a circular outside circumference, but it may have a regular polygonal shape inside the tank shell with the number of sides equal to the number of annular plates. These pieces shall be butt-welded in accordance with Q.7.1.1, Item b.

Q.3.4.4 The plates of the first shell course shall be attached to the annular bottom plates by a weld as required by 5.9.5 except when a full-penetration weld is used or required (see Q.7.1.1).

Table Q-3—Maximum Allowable Stress Values

ASTM Specifications	Stress Value (lbf/in. ²)			
	Specified Minimum		Allowable Stress	
	Tensile Strength	Yield Strength	Design	Test
Plate and Structural Members				
A 353	100,000	75,000	a	a
A 553, Type 1	100,000	85,000	a	a
A 645	95,000	65,000	31,700 ^b	42,000 ^b
A 240, Type 304	75,000	30,000	22,500	27,000
A 240, Type 304L	70,000	25,000	18,750	22,500
B 209, Alloy 3003-0	14,000	5,000	3,750	4,500
B 209, Alloy 5052-0	25,000	9,500	7,100	8,550
B 209, Alloy 5083-0	40,000 ^g	18,000 ^g	13,300 ^g	16,200 ^g
B 209, Alloy 5086-0	35,000	14,000	10,500	12,600
B 209, Alloy 5154-0	30,000	11,000	8,250	9,900
B 209, Alloy 5456-0	42,000 ^g	19,000 ^g	14,000 ^g	17,100 ^g
B 221, Alloy 3003-0	14,000	5,000	3,750	4,500
B 221, Alloy 5052-0	25,000	10,000	7,500	9,000
B 221, Alloy 5083-0	39,000	16,000	12,000	14,400
B 221, Alloy 5086-0	35,000	14,000	10,500	12,600
B 221, Alloy 5154-0	30,000	11,000	8,250	9,900
B 221, Alloy 5456-0	41,000	19,000	13,600	17,100
B 221, Alloys 6061-T4 and T6	24,000		8,000	10,000
B 308, Alloys 6061-T4 and T6	24,000		8,000	10,000
Piping and Tubing				
A333, Grade 8	100,000	75,000	a	a
A 334, Grade 8	100,000	75,000	a	a
A 213, Grade TP, Type 304	75,000	30,000	22,500	27,000
A 213, Grade TP, Type 304L	70,000	25,000	18,750	22,500
A 312, Grade TP, Type 304 ^c	75,000	30,000	22,500	27,000
A 312, Grade TP, Type 304L ^c	70,000	25,000	18,750	22,500
A 358, Grade 304, Class I	75,000	30,000	22,500	27,000
B 210, Alloy 3303-0	14,000	5,000	3,750	4,500
B 210, Alloy 3003-H112	14,000	5,000	3,750	4,500
B 210, Alloy 5052-0	25,000	10,000	7,500	9,000
B 210, Alloy 5086-0	35,000	14,000	0,500	12,600
B 210, Alloy 5154-0	30,000	11,000	8,250	9,900
B 241, Alloy 5052-0	25,000	10,000	7,500	9,000
B 241, Alloy 5083-0	39,000	16,000	12,000	14,400

Table Q-3—Maximum Allowable Stress Values (Continued)

ASTM Specifications	Stress Value (lbf/in. ²)			
	Specified Minimum		Allowable Stress	
	Tensile Strength	Yield Strength	Design	Test
B 241, Alloy 5086-0	35,000	14,000	10,500	12,600
B 241, Alloy 5454-0	31,000	12,000	9,000	10,800
B 241, Alloy 5456-0	41,000	19,000	13,650	17,100
B 444 (UNS-N06625), Grade 1	120,000	60,000	40,000 ^f	54,000 ^f
B 444 (UNS-N06625), Grade 2	100,000	40,000	30,000 ^f	36,000 ^f
B 619 (UNS-N10276), Class I ^c	100,000	41,000	30,750 ^f	36,900 ^f
B 622 (UNS-N10276)	100,000	41,000	30,750 ^f	36,900 ^f
Forgings				
A 522	100,000	75,000	a	a
A 182, Grade F, Type 304	75,000	30,000	22,500	27,000
A 182, Grade F, Type 304L	65,000	25,000	18,750	22,500
B 247, Alloy 3003-H112	14,000	5,000	3,750	4,500
B 247, Alloy 5083-H112 Mod ^d	38,000	16,000	12,000	14,400
Bolting ^e				
B 211, Alloy 6061-T6	42,000	35,000	10,500	
A 320 (strain-hardened: Grade B8, B8C, B8M and B8T)				
≤ ¾ in.	125,000	100,000	30,000	
> ¾ – 1 in.	115,000	80,000	26,000	
> 1 – 1¼ in.	105,000	65,000	21,000	
> 1¼ – 1½ in.	100,000	50,000	16,000	
A 320 (solution-treated and strain-hardened grades when welded)				
Grades B8, B8M, and B8T-all sizes	75,000	30,000	15,000	

Notes:

^aThe allowable stresses for these materials are based on the lower yield and tensile strength of the weld metal or base metal, as determined by Q.6.1, and the design rules in Q.3.3.2. The minimum measured tensile strength shall be 95,000 lbf/in.² and minimum measured yield strength shall be 52,500 lbf/in.². The maximum permitted values to be used for determining the allowable stress are 100,000 lbf/in.². for tensile strength and 58,000 lbf/in.² for yield strength.

^bBased on the yield and tensile strength of the weld metal, as determined by Q.6.1. The minimum measured tensile strength shall be 95,000 lbf/in.² and the minimum measured yield strength shall be 52,500 lbf/in.².

^cFor welding piping or tubing, a joint efficiency of 0.80 shall be applied to the allowable stresses for longitudinal joints in accordance with 5.23.3.

^dThe designation Mod requires that the maximum tensile and yield strength and the minimum elongation of the material conform to the limits of B 209, Alloy 5083-0.

^eSee 5.6.6.

^gThese allowable stress values are for materials thickness up to and including 1.5 in. For thickness over 1.5 in., allowable stress values are to be established per Q.3.3.2 using ASTM data of tensile (ultimate) and yield strength for these grades.

^fNot to be used for opening reinforcement when used with A 353, A 553, and A 645.

Table Q-4A—Minimum Thickness for the Annular Bottom Plate: Steel Tanks

Nominal Thickness of First Shell Course (in.)	Design Stress ^a in First Shell Course (lbf/in. ²)					
	≤ 19,000	22,000	25,000	28,000	31,000	34,000
≤ 0.75	1/4	1/4	1/4	9/32	11/32	13/32
> 0.75 – 1.00	1/4	1/4	9/32	11/32	7/16	17/32
> 1.00 – 1.25	1/4	1/4	11/32	7/16	17/32	21/32
> 1.25 – 1.50	—	9/32	13/32	17/32	21/32	25/32

Notes:

The thicknesses and widths (see Q.3.4.1) in this table are based on the foundation providing a uniform support under the full width of the annular plate. Unless the foundation is properly compacted, particularly at the inside of a concrete ringwall, settlement will produce additional stresses in the annular plate. The thickness of the annular bottom plates need not exceed the thickness of the first shell course. The minimum thicknesses for annular bottom plates were derived based on a fatigue cycle life of 1000 cycles for aluminum tanks.

^aThe stress shall be calculated using the formula $[(2.6D) \times (HG)]/t$, where D = nominal diameter of the tank, in ft; H = maximum filling height of the tank for design, in ft; G = design specific gravity; and t = design thickness of the first shell course, excluding corrosion allowance, in in.

Table Q-4B—Minimum Thickness for the Annular Bottom Plate: Aluminum Tanks

Nominal Thickness of First Shell Course (in.)	Design Stress ^a in First Shell Course (lbf/in. ²)					
	12,000	13,000	14,000	15,000	16,000	17,000
≤ 0.50	1/4	1/4	9/32	9/32	5/16	5/16
> 0.50 – 0.75	11/32	3/8	13/32	15/32	1/2	17/32
> 0.75 – 1.00	15/32	17/32	19/32	5/8	11/16	23/32
> 1.00 – 1.25	5/8	11/16	3/4	13/16	7/8	29/32
> 1.25 – 1.50	3/4	13/16	29/32	31/32	1 1/32	1 1/8
> 1.50 – 1.75	7/8	1	1 1/16	1 5/32	1 1/4	1 5/16
> 1.75 – 2.00	1	1 1/8	1 7/32	1 5/16	1 13/32	1 1/2

Notes:

The thicknesses and widths (see Q.3.4.1) in this table are based on the foundation providing a uniform support under the full width of the annular plate. Unless the foundation is properly compacted, particularly at the inside of a concrete ringwall, settlement will produce additional stresses in the annular plate. The thickness of the annular bottom plates need not exceed the thickness of the first shell course. The minimum thicknesses for annular bottom plates were derived based on a fatigue cycle life of 1000 cycles for aluminum tanks.

^aThe stress shall be calculated using the formula $[(2.6D) \times (HG)]/t$, where D = nominal diameter of the tank, in ft; H = maximum filling height of the tank for design, in ft; G = design specific gravity; and t = design thickness of the first shell course, excluding corrosion allowance, in in.

Q.3.4.5 Butt-welds in annular plates shall be not closer than 12 in. from any vertical weld.

Q.3.4.6 Three-plate laps or butt-weld junctions in tank bottoms shall be not closer than 12 in. from each other or from the butt-welds of the annular plates.

Q.3.4.7 Bottom plates, other than annular bottom plates for a 9% or 5% nickel steel or stainless steel tank that contains liquid, may have a minimum thickness of $\frac{3}{16}$ in. exclusive of any specified corrosion allowance.

Q.3.5 SHELL STIFFENING RINGS FOR TANKS THAT CONTAIN LIQUID

Q.3.5.1 Internal or external shell stiffening rings may be required to maintain roundness when the tank is subjected to wind, vacuum, or other specified loads. When stiffening rings are required, the stiffener-to-shell weld details shall be in accordance with Figure Q-1 and Q.3.5.2 through Q.3.5.5.

Q.3.5.2 The stiffener ring and backing strip (if used) are primary components, and they shall comply with the requirements of Q.2.1. The stiffener rings may be fabricated from plate using an intermittent weld on alternating sides between the web and the flange.

Q.3.5.3 One rat hole with a minimum radius of $\frac{3}{4}$ in. shall be provided at each longitudinal shell joint and ring juncture weld (see Figure Q-1).

Q.3.5.4 Except for aluminum or stainless steel tanks, all fillet welds shall consist of a minimum of two passes. The ends of the fillet welds shall be 2 in. from the rat hole (see Figure Q-1), and these welds shall be deposited by starting 2 in. from the rat hole and welding away from the rat hole. An acceptable alternative to the detail that includes stopping fillet welds 2 in. short of the rat hole would be to weld continuously through the rat hole from one side of the stiffener to the opposite side. All craters in fillet welds shall be repaired by back welding.

Q.3.5.5 Any joints between the adjacent sections of stiffening rings, as shown in Figure Q-1, shall be made so that the required moment of inertia of the combined ring-shell section is provided. Weld joints between adjacent sections shall be made with full-thickness and full-penetration butt-welds. Stiffening-ring butt-welds may employ metal backing strips. Backing strips and the associated welding shall be made in a manner that provides a smooth contour in the rat hole and all other weld joint ends. All weld passes shall be started at the rat hole and other weld joint ends and shall be completed by moving away from these ends. Passes shall be overlapped away from edges to provide a smooth continuous weld.

Q.3.6 TANK ANCHORAGE

Q.3.6.1 In addition to the loads in Q.4, Q.5.1, and Q.5.2, the anchorage for the tank that contains liquid, whether it be a single-wall tank or the inner tank of a double-wall tank, shall be designed to meet the requirements of Q.3.6.2 through Q.3.6.5.

Q.3.6.2 The anchorage shall accommodate movement of the tank wall and bottom caused by thermal changes.

Q.3.6.3 For Appendix Q tanks, 9% or 5% nickel steel, stainless steel, or aluminum anchorage may be used; carbon steel may be used when a corrosion allowance is provided. Aluminum anchorage shall not be imbedded in reinforced concrete unless it is suitably protected against corrosion.

Q.3.6.4 For anchored flat-bottom tanks, the anchorage shall be designed as described in Q.3.6.4.1 through Q.3.6.4.3.

Q.3.6.4.1 When the topshell course is the minimum thickness indicated in 5.10.4 and Figure 5-6, details a–e, h, and i, the minimum anchorage shall be designed for normal loads as specified by the purchaser and by this standard. See 5.11.2.3 for the allowable stress.

Q.3.6.4.2 When the topshell course is thickened as in Figure 5-6, details f and g, or a knuckle is used, the minimum anchorage shall be designed for three times the internal design pressure. The allowable stress for this loading is 90% of the minimum specified yield strength of anchorage material.

Q.3.6.4.3 As an alternative to Q.3.6.4.2, the purchaser may specify a combination of normal anchorage design, (see Q.3.6.4.1) and emergency venting.

Q.3.6.5 The foundation design loading for Q.3.6.4 is described in Q.10.4.4.

Q.4 Design of a Single-Wall Tank

The purchaser shall specify the design metal temperature and pressures (internal and external), specific gravity of the content to be stored, roof live loads, wind load, earthquake load where applicable, and corrosion allowance, if any.

Q.5 Design of a Double-Wall Tank

Q.5.1 DESIGN SPECIFICATIONS

The outer bottom, shell, and roof of a double-wall tank shall enclose an insulating space around the bottom, shell, and roof or insulation deck of the inner tank that contains the stored liquid. The annular space shall be maintained at a low positive pressure, which necessitates that the enclosure be vapor-tight. The purchaser shall specify the design metal temperature and pressure of the inner tank and may specify the design temperature and pressure of the outer tank. The

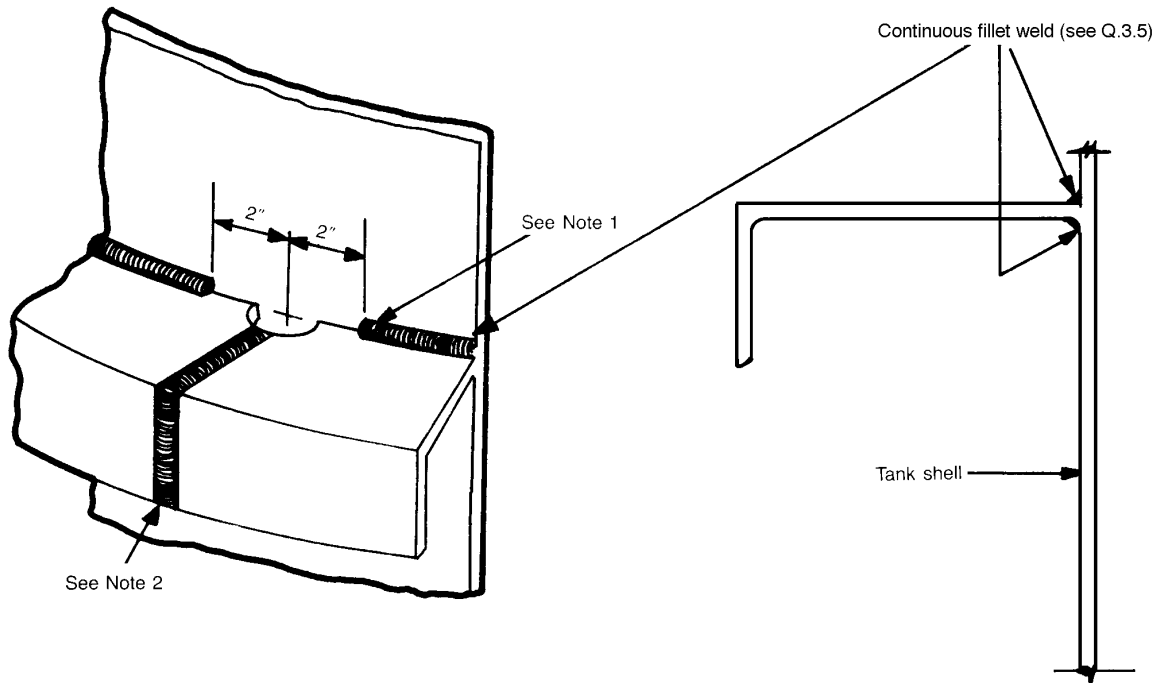

Notes:

1. See Q.3.5.4 for alternative fillet-weld termination details.
2. Backing strips are permitted on stiffening-ring junction welds.

Figure Q-1—Typical Stiffening-Ring Weld Details

purchaser shall state the specific gravity of the content to be stored, roof live loads, wind load, earthquake load where applicable, and corrosion allowance, if any.

Q.5.2 COMBINATION OF DESIGN LOADS

Q.5.2.1 Inner Tank

The inner tank shall be designed for the most critical combinations of loading that result from internal pressure and liquid head, the static insulation pressure, the insulation pressure as the inner tank expands after an in-service period, and the purging or operating pressure of the space between the inner and outer tank shells, unless the pressure is equalized on both sides of the inner tank.

Q.5.2.2 Outer Wall

The outer wall shall be designed for the purging and operating pressure of the space between the inner and outer tank shells and for the loading from the insulation, the pressure of wind forces, and the roof loading.

Q.5.3 MINIMUM WALL REQUIREMENTS

Q.5.3.1 Outer Tank

The outer tank bottom, shell, and roof shall have a minimum nominal thickness of $\frac{3}{16}$ in. (7.65 lbf/ft²) and shall conform to the material requirements of Q.2.3.

Q.5.3.2 Inner Tank

In no case shall the nominal thickness of the inner tank cylindrical sidewall plates be less than that described in Table Q-5; the plates shall conform to the material requirements of Q.2.1.

Note: The nominal thickness of cylindrical sidewall plates refers to the tank shell as constructed. The thicknesses specified are based on erection requirements.

Q.5.3.3 Inner Tank Tolerances

For inner cylindrical walls, the tolerances shall be in accordance with 6.4.2.1, 6.4.2.2.2, 6.4.2.3, and Table Q-6, which supersedes Table 6-1.

Table Q-5—Nominal Thickness of Inner Tank Cylindrical Sidewall Plates

Nominal Cylinder Diameter (ft)	Nominal Plate Thickness (in.)
Stainless steel and nickel steel	
< 60	$\frac{3}{16}$
60 – 140	$\frac{1}{4}$
> 140 – 220	$\frac{5}{16}$
> 220	$\frac{3}{8}$
Aluminum	
< 20	$\frac{3}{16}$
20 – 120	$\frac{1}{4}$
> 120 – 200	$\frac{5}{16}$
> 200	$\frac{3}{8}$

Table Q-6—Radius Tolerances for the Inner Tank Shell

Diameter Range (ft)	Radius Tolerance (in.)
Stainless steel and nickel steel	
< 140	$\pm \frac{3}{4}$
140 – 220	± 1
> 220	$\pm 1\frac{1}{4}$
Aluminum	
< 20	$\pm \frac{1}{2}$
20 – 120	$\pm \frac{3}{4}$
> 120 – 200	± 1
> 200	$\pm 1\frac{1}{4}$

Q.6 Welding Procedures

The rules in this section shall apply to all primary components of the tank. Covered electrodes and bare-wire electrodes used to weld 9% and 5% nickel steel shall be limited to those listed in AWS 5.11 and AWS 5.14. The secondary components shall be welded in accordance with the basic rules of this standard unless the requirements of this appendix or Appendix R are applicable.

The outer tank, which is not in contact with the vaporized liquefied gas, may be of single-welded lap or single-welded butt construction when the thickness does not exceed $\frac{3}{8}$ in.; at any thickness, the outer tank may be of double-welded butt construction without necessarily having full fusion and penetration. Single-welded joints shall be welded from the outside to prevent corrosion and the entrance of moisture.

When the outer tank is in contact with the vaporized liquefied gas, it shall conform to the lap- or butt-welded construction described in this standard except as required in Q.7.1.2.2.

Q.6.1 WELDING PROCEDURE QUALIFICATION

Specifications for the standard welding procedure tests and confirmation of the minimum ultimate tensile strength are found in 6.7. When the weld filler metal has an unspecified yield strength, a specified minimum yield or ultimate tensile strength below the specified minimums for the base metal, or the welding procedure qualification test shows the deposited weld metal tensile test strength is lower than the specified minimum ultimate tensile strength of the base metal; two all-weld-metal specimens that conform to the dimensional standard of Figure 9 of AWS A5.11 shall be tested to determine the minimum yield and ultimate tensile strength required by Table Q-3; or for determining allowable stress values in Q.3.3.2. The yield strength shall be determined by the 0.2% Offset Method.

Q.6.2 IMPACT TESTS FOR 9% AND 5% NICKEL STEEL

Impact tests for primary components of 9% and 5% nickel steel shall be made for each welding procedure as described in Q.6.2.1 through Q.6.2.5.

Q.6.2.1 Charpy V-notch specimens shall be taken from the weld metal and from the heat-affected zone of the welding procedure qualification test plates or from duplicate test plates.

Q.6.2.2 Weld metal impact specimens shall be taken across the weld with the notch in the weld metal. The specimen shall be oriented so that the notch is normal to the surface of the material. One face of the specimen shall be substantially parallel to and within $\frac{1}{16}$ in. of the surface.

Q.6.2.3 Heat-affected zone impact specimens shall be taken across the weld and as near the surface of the material as is practicable. The specimens shall be of sufficient length to locate the notch in the heat-affected zone after etching. The notch shall be cut approximately normal to the material surface to include as much heat-affected zone material as possible in the resulting fracture.

Q.6.2.4 Impact test specimens shall be cooled to the temperature stated in Q.22.

Q.6.2.5 The required impact values and lateral expansion values of the weld metal and the heat-affected zone shall be as given in Q.2.2.2, items c and d, respectively. Where erratic impact values are obtained, retests will be allowed if agreed upon by the purchaser and the manufacturer.

Q.6.3 IMPACT TESTS FOR HIGH ALLOYS

Q.6.3.1 Impact tests are not required for the high-alloy (austenitic stainless steel) base materials, nickel alloy based materials, aluminum base materials, and weld deposited for the nonferrous (aluminum) materials.

Q.6.3.2 Impact tests are not required for austenitic stainless steel welds deposited by all the welding processes for services of -200°F and above.

Q.6.3.3 Austenitic stainless steel welds deposited for service below -200°F by all welding processes shall be impact tested in accordance with Q.6.2 except that the required impact values shall be 75% of the values as given in Q.2.2.2, item c. Electrodes used in the production welding of the tank shall be tested to meet the above requirements.

Q.6.3.4 Impact tests are not required for nickel alloy welds made with electrodes/filler metals covered by AWS Specification A5.11 or AWS Specification A5.14, provided the nominal nickel content is 50% or greater, and the weld is deposited by the shielded metal-arc welding (SMAW), gas metal-arc welding (GMAW), gas tungsten-arc welding (GTAW), or plasma-arc welding (PAW) processes. When A5.11/A5.14 specifies the nickel content as a "remainder," the nickel content shall be determined by summing the maximum specified values of the other elements (use the average specified value for elements with specified ranges) and subtracting from 100%.

Q.6.4 IMPACT TESTS FOR SECONDARY COMPONENTS

When impact tests are required by Q.2.3.1 for secondary components, they shall conform to the requirements of ASTM A 20, Supplementary Requirement, paragraph S 5, this appendix, or Appendix R, whichever is applicable.

Q.6.5 PRODUCTION WELDING PROCEDURES

The production welding procedures and the production welding shall conform to the requirements of the procedure qualification tests within the following limitations:

- Individual weld layer thickness shall not be substantially greater than that used in the procedure qualification test.
- Electrodes shall be of the same AWS classification and shall be of the same nominal size or smaller.
- The nominal preheat and interpass temperatures shall be the same.

Q.6.6 PRODUCTION WELD TESTS

Q.6.6.1 Production weld test plates shall be welded for primary-component butt-welded shell plates when welding procedure qualifications are required to be impact tested per Q.6.2 and Q.6.3. The number of production weld tests shall be based on the requirements of Q.6.6.3 and Q.6.6.4. The locations impact tested (i.e., HAZ and/or weld deposits) shall likewise be the same as required for weld procedure qualifications per Q.6.2 and Q.6.3. Weld testing shall be in accordance with Q.6.6.5. Test plates shall be made from plates produced only from the heats that are used to produce the shell plates for the tank.

Q.6.6.2 Test plates shall be welded using the same qualified welding procedure and electrodes that are required for the tank shell plate joints. The test plates need not be welded as an extension of the tank shell joint but shall be welded in the required qualified positions.

Q.6.6.3 One test weld shall be made on a set of plates from each specification and grade of plate material, using a thickness that would qualify for all thicknesses in the shell. Each test welded of thickness t shall qualify for plate thicknesses from $2t$ down to $t/2$, but not less than $5/8$ in. For plate thicknesses less than $5/8$ in., a test weld shall be made for the thinnest shell plate to be welded; this test weld will qualify plate thicknesses from t up to $2t$.

Q.6.6.4 Test welds shall be made for each position and for each process used in welding the tank shell, but a manual vertical weld will qualify manual welding of all positions. Test welds are not required for machine welded circumferential joints in cylindrical shells.

Q.6.6.5 The impact specimens and testing procedure shall conform to Q.6.2.1 through Q.6.2.5 for 9-percent and 5-percent nickel steel. The impact specimens and testing procedure shall conform to Q.6.3.3 for austenitic stainless steel welds deposited for service below -200°F .

Q.6.6.6 By agreement between the purchaser and the manufacturer, production test welds for the first tank shall satisfy the requirements of this paragraph for similar tanks at the same location if the tanks are fabricated within 6 months of the time the impact tests were made and found satisfactory. A change in any essential variable shall require additional production testing.

Q.7 Requirements for Fabrication, Openings, and Inspection

Q.7.1 WELDING OF PRIMARY COMPONENTS

Q.7.1.1 The following primary components shall be joined with double butt-welds that have complete penetration and complete fusion except as noted:

- Longitudinal and circumferential shell joints.
- Joints that connect the annular bottom plates together.
- Joints that connect sections of compression rings and sections of shell stiffeners together. Backup bars may be used for these joints with complete penetration and complete fusion detail.
- Joints around the periphery of a shell insert plate.
- Joints that connect the shell to the bottom, unless a method of leak checking is used (see Q.8.2.1), in which case double fillet welds are acceptable (see Q.8.2.2).

Q.7.1.2 Fillet welds shall be made in the manner described in Q.7.1.2.1 through Q.7.1.2.3.

Q.7.1.2.1 All primary components joined together by fillet welds shall have a minimum of two passes, except aluminum material and as permitted for stiffening ring attachment to shell (see Q.3.5.4).

Q.7.1.2.2 Outer tank bottom components exposed to vaporized liquefied gas and joined together by fillet welds shall have a minimum of two passes.

Q.7.1.2.3 For 9% nickel material, sandblasting or other adequate means must be used to remove mill scale from all plate edges and surfaces before fillet welds in contact with the refrigerated liquid and vaporized liquefied gas are welded. Sandblasting, or other adequate means, is required to remove slag from the first welding pass if coated electrodes are used.

Q.7.1.2.4 Slip-on flanges may be used where specifically approved by the purchaser.

Q.7.1.3 Butt-welds in piping nozzles, manway necks, and pipe fittings, including weld neck flanges, shall be made using double butt-welded joints. When accessibility does not permit the use of double butt-welded joints, single butt-welded joints that ensure full penetration through the root of the joint are permitted.

Q.7.2 CONNECTIONS IN PRIMARY COMPONENTS

Q.7.2.1 All connections located in primary components shall have complete penetration and complete fusion.

Q.7.2.2 Acceptable types of welded opening connections are shown in Figure 5-8, panels a, b, c, g, h, m, and o.

Q.7.2.3 Flanges for nozzles and manways shall be in accordance with this standard; however, the material shall comply with the requirements of Q.2.1 or Q.2.2.

Q.7.3 POSTWELD HEAT TREATMENT

Q.7.3.1 Cold-formed 9% and 5% nickel plates shall be postweld heat treated (or stress relieved) when the extreme fiber strain from cold forming exceeds 3% as determined by the formula:

$$s = \frac{65t}{R_f} \left(1 - \frac{R_f}{R_o} \right)$$

where

s = strain, in percent,

t = plate thickness, in in.,

R_f = final radius, in in.,

R_o = original radius, in in. (infinity for flat plate).

Q.7.3.2 If postweld heat treatment (or stress relief) is required for 9% and 5% nickel, the procedure shall be in accordance with paragraph UCS-56 in Section VIII of the ASME Code (with a holding temperature range from 1025°F

to 1085°F), but the cooling rate from the postweld heat treatment shall be not less than 300°F per hour down to a temperature of 600°F. A vessel assembly, or plate that requires postweld heat treatment, must be postweld heat treated in its entirety at the same time. Methods for local or partial postweld heat treatment cannot be used. Pieces individually cold formed that require postweld heat treatment may be heat treated before being welded into the vessel or assembly.

Q.7.3.3 Postweld heat treatment of nonferrous materials is normally not necessary or desirable. No postweld heat treatment shall be performed except by agreement between the purchaser and the manufacturer.

Q.7.3.4 Postweld heat treatment of austenitic stainless steel materials is neither required nor prohibited, but paragraphs UHA-100 through UHA-109 in Section VIII of the ASME Code should be carefully reviewed in case postweld heat treatment should be considered by the purchaser or the manufacturer.

Q.7.4 SPACING OF CONNECTIONS AND WELDS

Q.7.4.1 In primary components, all opening connections 12 in. or larger in nominal diameter in a shell plate that exceeds 1 in. in thickness shall conform to the spacing requirements for butt and fillet welds described in Q.7.4.2 through Q.7.4.4.

Q.7.4.2 The butt-weld around the periphery of a thickened insert plate, or the fillet weld around the periphery of a reinforcing plate, shall be at least the greater of 10 times the shell thickness or 12 in. from any butt-welded seam or the bottom-to-shell or roof-to-shell joint. As an alternative, the insert plate (or the reinforcing plate in an assembly that does not require stress relief) may extend to and intersect a flat-bottom-to-shell corner joint at approximately 90 degrees.

Q.7.4.3 In cylindrical tank walls, the longitudinal weld joints in adjacent shell courses, including compression ring welds, shall be offset from each other a minimum distance of 12 in.

Q.7.4.4 Radial weld joints in a compression ring shall be not closer than 12 in. from any longitudinal weld in an adjacent shell or roof plate.

Q.7.5 INSPECTION OF WELDS BY THE LIQUID-PENETRANT METHOD

The following primary-component welds shall be inspected by the liquid-penetrant method after stress relieving, if any, and before the hydrostatic test of the tank:

- All longitudinal and circumferential butt-welds not completely radiographed. Inspection shall be on both sides of the joint.
- The welded joint that joins the cylindrical wall of the tank to the bottom annular plates.

c. All welds of opening connections that are not completely radiographed, including nozzle and manhole neck welds and neck-to-flange welds. Inspection shall also include the root pass and every 1/2 in. of thickness of deposited weld metal (see 5.27.11) as welding progresses.

d. All welds of attachments to primary components, such as stiffeners, compression rings, clips, and other nonpressure parts.

e. All welded joints on which backing strips are to remain shall also be examined by the liquid-penetrant method after the first two layers (or beads) of weld metal have been deposited.

04 | **Q.7.6 RADIOGRAPHIC/ULTRASONIC EXAMINATION OF BUTT-WELDS IN PLATES**

Primary-component butt-welds shall be examined by radiographic or ultrasonic methods. When the term "examination" is used in section Q.7.6 and its subsections, it shall be understood to refer to radiographic or ultrasonic examination.

04 | The extent of the examination shall be as described in Q.7.6.1 through Q.7.6.7. When the examination is by the ultrasonic method, it shall be done in accordance with the requirements of Appendix U.

04 | **Q.7.6.1** Butt-welds in all tank wall courses subjected to a maximum actual operating membrane tensile stress, perpendicular to the welded joint, greater than 0.1 times the specified minimum tensile strength of the plate material shall be completely examined.

04 | **Q.7.6.2** Butt-welds in all tank wall courses subjected to maximum actual operating membrane tensile stress, perpendicular to the welded joint, less than or equal to 0.1 times the specified minimum tensile strength of plate material shall be spot examined in accordance with Figure Q-2.

04 | **Q.7.6.3** Butt-welds around the periphery of a thickened insert plate shall be completely examined. This does not include the weld that joins the insert plate with the bottom plate of a flat-bottom tank.

04 | **Q.7.6.4** Butt-welds at all three-plate junctions in the tank wall shall be examined except in the case of a flat bottom (wall) supported uniformly by the foundation. This does not include the shell-to-bottom weld of a flat-bottom tank. See Figure Q-2 for minimum examination dimensions.

04 | **Q.7.6.5** Twenty-five percent of the butt-welded annular plate radial joints shall be spot examined for a minimum length of 6 in. The location shall be at the outer edge of the joint and under the tank shell.

04 | **Q.7.6.6** Twenty-five percent of the butt-welded compression bar radial joints shall be spot examined for a minimum length of 6 in., except as required by 5.26.4.3.

Q.7.6.7 For aluminum tanks the radiography shall be judged according to the requirements of ASME B96.1.

Q.7.7 RADIOGRAPHIC INSPECTION OF BUTT-WELDS IN PIPING

Q.7.7.1 Butt-welds in piping and in pipe fittings within the limitations of 1.3.2 (including the annular space of double-wall tanks) shall be radiographically inspected in conformance with Q.7.7.2 through Q.7.7.5.

Q.7.7.2 Longitudinal welded joints in piping that contains liquid shall be completely radiographed except for manufactured pipe welded without filler metal, 12 in. or less in diameter, which is hydrostatically tested to ASTM requirements.

Q.7.7.3 Longitudinal welded joints in piping that contains vapor shall be completely radiographed except for manufactured pipe welded without filler metal, 18 in. or less in diameter, which is hydrostatically tested to ASTM requirements.

Q.7.7.4 Thirty percent of the circumferential welded joints in all piping shall be 100% radiographed.

Q.7.7.5 Butt-welded joints used to fabricate tank fittings shall be completely radiographed.

Q.7.8 PERMANENT ATTACHMENTS

All permanent structural attachments welded directly to 9% and 5% nickel steel shall be of the same material or of an austenitic stainless steel type that cannot be hardened by heat treatment.

Q.7.9 NON-PRESSURE PARTS

Welds for pads, lifting lugs, and other nonpressure parts, as well as temporary lugs for alignment and scaffolding attached to primary components, shall be made in full compliance with a welding procedure qualified in accordance with Q.6.1. Lugs attached for erection purposes shall be removed, and any significant projections of weld metal shall be ground to a smooth contour. Plate that is gouged or torn in removing the lugs shall be repaired using a qualified procedure and then ground to a smooth contour. Where such repairs are made in primary components, the area shall be inspected by the liquid-penetrant method. A visual inspection is adequate for repairs in secondary components.

Q.7.10 REPAIRS TO WELDED JOINTS

When repairs are made to welded joints, including the welds in Q.7.9, the repair procedure shall be in accordance with a qualified welding procedure.

Q.7.11 MARKING OF MATERIALS

Q.7.11.1 Material for primary components shall be marked so that the individual components can be related back to the mill test report. For aluminum materials, a certificate of conformance shall be provided in place of a mill test report

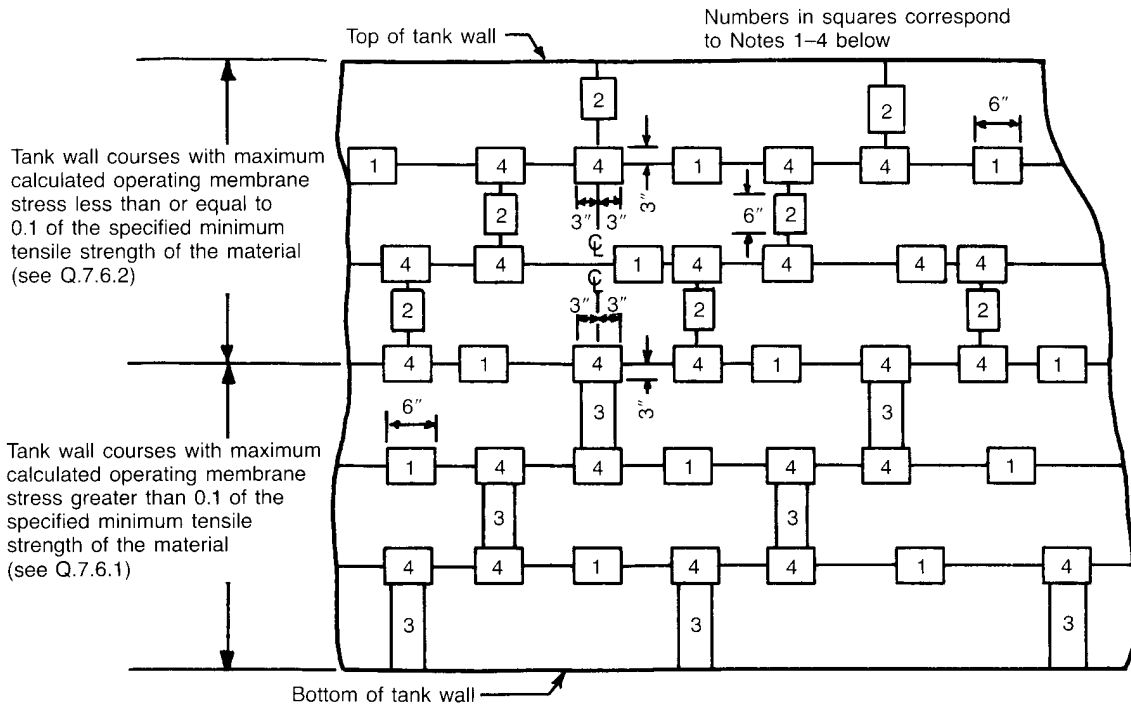

Notes:

1. One circumferential spot examination shall be performed in the first 10 feet for each welding operator of each type and thickness. After the first 10 feet, without regard to the number of welders, one circumferential spot examination shall be performed between each longitudinal joint on the course below.
2. One longitudinal spot examination shall be performed in the first 10 feet for each welder or welding operator of each type and thickness. After the first 10 feet, without regard to the number of welders, one longitudinal spot examination shall be performed in each longitudinal joint.
3. Longitudinal joints shall be 100-percent examined.
4. All intersections of joints shall be examined.

Figure Q-2—Radiographic/Ultrasonic Examination Requirements for Butt-Welded Shell Joints in Cylindrical Flat-Bottom Tanks

stating that the material has been sampled, tested, and inspected in accordance with the specifications and has met the requirements.

Q.7.11.2 All markings shall be made with a material that is compatible with the base material or with a round-bottom, low-stress die; however, 9% nickel or stainless steel less than 1/4-in. thick shall not have a die stamp.

Q.7.11.3 Under some conditions, marking material that contains carbon or heavy-metal compounds can cause corrosion of aluminum. Chalk, wax-base crayons, or marking inks with organic coloring are usually satisfactory.

Q.7.12 CONSTRUCTION PRACTICES

Excessive hammering should be avoided on primary components so that the material is not hardened or severely

dentured. Any objectionable local thinning caused by hammering can be repaired by welding using a qualified procedure, followed by grinding. The extent of rework for any repair that is permissible must be agreed to between the purchaser and the manufacturer. If the rework is determined to have been excessive, the reworked area should be cut out and replaced.

Q.7.13 PROTECTION OF PLATES DURING SHIPPING AND STORAGE

Plates shall be adequately protected during shipping and storage to avoid damage to plate surfaces and edges from handling (scratches, gouge marks, etc.) and from environmental conditions (corrosion, pitting, etc.)

Q.7.13.1 Plates shall be protected from moisture or stored in inclined position to prevent water from collecting and standing on surface.

Q.7.13.2 Nine percent and five percent nickel plates which are exposed to humid or corrosive atmosphere shall be sand or grit blasted and coated with a suitable coating. The purchaser shall specify when plates are exposed to humid or corrosive atmosphere.

Q.8 Testing the Tank in Contact With the Refrigerated Product

The provisions stated in this section are testing requirements for the tank refrigerated by the liquid contents. Provisions noted in Q.9 cover the outer tank, which is not in contact with the refrigerated liquid and is subject to a higher temperature that approaches atmospheric.

Q.8.1 GENERAL PROCEDURE

Q.8.1.1 A thorough check for tightness and structural adequacy is essential for a single-wall tank or for the inner tank of a double-wall tank. Except as permitted by Q.8.6, the test shall be conducted after the entire tank is complete, before the insulation is applied. Except as limited by foundation or stress conditions, the test shall consist of filling the tank with water to the design liquid level and applying an overload air pressure of 1.25 times the pressure for which the vapor space is designed. Where foundation or stress conditions do not permit a test with water to the design liquid level, the height of water shall be limited as stated in Q.8.1.2 and Q.8.1.3.

Q.8.1.2 The load on the supporting foundation shall preferably not exceed the established allowable bearing value for the tank site. Where a thorough evaluation of the foundation justifies a temporary increase, the established allowable bearing may be increased for the test condition, but the increase shall be not more than 25%.

Q.8.1.3 The maximum fill shall not produce a stress in any part of the tank greater than 85% (may be 90% for stainless steel and aluminum materials) of the specified minimum yield strength of the material or 55% of the specified minimum tensile strength of the material.

Q.8.2 TEST PRELIMINARIES

Before the tank is filled with water, the procedures described in Q.8.2.1 through Q.8.2.5 shall be completed.

Q.8.2.1 All welded joints in the bottom and complete penetration and complete fusion corner joints between the shell and bottom shall be inspected by applying a solution film to the welds and pulling a partial vacuum of at least 3 lbf/in.² gauge above the welds by means of a vacuum box with a transparent top.

Q.8.2.2 When the corner weld in Q.8.2.1 does not have complete penetration and complete fusion, the initial weld passes, inside and outside of the shell, shall have all slag and

nonmetals removed from the surface of the welds and the welds examined visually. After completion of the inside and outside fillet or partial penetration welds, the welds shall be tested by pressurizing the volume between the inside and outside welds with air pressure to 15 lbf/in.² gauge and applying a solution film to both welds. To assure that the air pressure reaches all parts of the welds, a sealed blockage in the annular passage between the inside and outside welds must be provided by welding at one or more points. Additionally, a small pipe coupling communicating with the volume between the welds must be welded on each side of and adjacent to the blockages. The air supply must be connected at one end and a pressure gauge connected to a coupling on the other end of the segment under test.

Q.8.2.3 For 9% nickel tanks, all testing surfaces of bottom lap-welds and shell-to-bottom welds shall be cleaned by sandblasting or other adequate means before the vacuum box test to prevent slag or dirt from masking leaks.

Q.8.2.4 Where the pneumatic pressure to be applied in Q.8.4 will be equalized on both sides of the inner tank, all welded joints above the test water level shall be checked with a solution film and by a vacuum box inspection.

Q.8.2.5 The attachment fillet welds around bottom openings, which do not permit the application of air pressure behind their reinforcing plates, shall be inspected by applying a solution film and by a vacuum box inspection.

Q.8.3 QUALITY OF TEST WATER

Q.8.3.1 The materials used in the construction of Appendix Q tanks may be subject to severe pitting, cracking, or rusting if they are exposed to contaminated test water for extended periods of time. The purchaser shall specify a minimum quality of test water that conforms to Q.8.3.2 through Q.8.3.8. After the water test is completed, the tank shall be promptly drained, cleaned, and dried.

Q.8.3.2 Water shall be substantially clean and clear.

Q.8.3.3 Water shall have no objectionable odor (that is, no hydrogen sulfide).

Q.8.3.4 Water pH shall be between 6 and 8.3.

Q.8.3.5 Water temperature shall be below 120°F.

Q.8.3.6 For austenitic stainless steel tanks, the chloride content of the water shall be below 50 parts per million.

Q.8.3.7 For aluminum tanks, the mercury content of the water shall be less than 0.005 parts per million, and the copper content shall be less than 0.02 parts per million.

Q.8.3.8 If the water quality outlined in Q.8.3.1 through Q.8.3.7 cannot be achieved, alternative test methods that utilize suitable inhibitors (for example, Na_2CO_3 and/or NaO_3) may be used if agreed to by the purchaser and the manufacturer.

Q.8.4 HYDROSTATIC TEST

Q.8.4.1 The tank shall be vented to the atmosphere when it is filled with or emptied of water.

Q.8.4.2 During water filling, the elevations of at least four equidistant points at the bottom of the tank shell and on top of the ringwall or slab shall be checked. Differential settlement, or uniform settlement of substantial magnitude, requires an immediate stop to water filling. Any further filling with water will depend on an evaluation of the measured settlement.

Q.8.4.3 The tank shall be filled with water to the design liquid level unless height is limited as noted in Q.8.1.

Q.8.4.4 After the tank is filled with water and before the pneumatic pressure is applied, anchorage, if provided, shall be tightened against the hold-down brackets.

Q.8.4.5 All welds in the shell, including the corner weld between the shell and the bottom, shall be visually checked for tightness.

Q.8.5 PNEUMATIC PRESSURE

Q.8.5.1 An air pressure equal to 1.25 times the pressure for which the vapor space is designed shall be applied to the enclosed space above the water level. In the case of a double-wall tank with an open-top inner tank, where the air pressure acts against the outer tank and the inner tank is thus not stressed by the air pressure, the inner tank may be emptied of water before the pneumatic pressure test begins.

Q.8.5.2 The test pressure shall be held for 1 hour.

Q.8.5.3 The air pressure shall be reduced until the design pressure is reached.

Q.8.5.4 Above the water level, all welded joints, all welds around openings, and all piping joints against which the pneumatic pressure is acting shall be checked with a solution film. A visual inspection may be substituted for the solution-film inspection if the welded joint has previously been checked with a vacuum box. The solution-film inspection shall still be made, above the water level, on all welds around openings, all piping joints, and the compression ring welds, including the attachment to the roof and shell.

Q.8.5.5 The opening pressure or vacuum of the pressure relief and vacuum relief valves shall be checked by pumping air above the water level and releasing the pressure and then partially withdrawing water from the tank.

Q.8.5.6 After the tank has been emptied of water and is at atmospheric pressure, the anchorage, if provided, shall be rechecked for tightness against the hold-down brackets.

Q.8.5.7 Air pressure, equal to the design pressure, shall be applied to the empty tank, and the anchorage, if provided, and the foundation shall be checked for uplift.

Q.8.5.8 All welded seams in the bottom and the corner weld, between the shell and bottom, shall be inspected by means of a solution film and vacuum box test similar to that described in Q.8.2.1 and Q.8.2.2.

Q.8.6 TEMPORARY OPENINGS AFTER HYDROSTATIC TEST

When approved by the purchaser in writing, and only in the case of tanks which when complete have no shell penetrations, it is permitted to restore by welding up to four temporary shell openings after the hydrostatic test in accordance with the provisions of this section.

Q.8.6.1 Each temporary opening shall be restored by the insertion of a shell plate that matches the thickness and specification of adjacent shell material, and is welded into place with full fusion butt-welds. The insert plate shall be round with diameter no less than 24 in. and no greater than 42 in.

Q.8.6.2 The insert plate weld shall not cross any shell seams and shall be at least the greater of 10 times the shell thickness or 12 in. from any other weld in the shell including shell seams, shell-to-bottom weld or attachment welds.

Q.8.6.3 The butt weld around the periphery of the plate shall be examined over 100% of its length by both liquid penetrant method and radiographic method. The liquid penetrant examination is required on the root pass, on the back-gouged surface, and on the inside and outside finished weld surfaces. Additionally, the weld shall be vacuum box leak tested.

Q.9 Testing the Outer Tank of a Double-Wall Refrigerated Tank

Q.9.1 GENERAL

The tightness test shall be made before insulation is installed. Where the pneumatic pressure described in Q.8.5 acts against the outer tank, the testing requirements of Q.8.5 will result in a check of the outer tank, and the procedure outlined in Q.9.2.1 through Q.9.2.5 may be omitted.

Q.9.2 TEST PROCEDURE

Q.9.2.1 The inner tank shall be opened to the atmosphere, and a sufficient amount of water shall be added to the inner tank to balance the upward pressure against the inner tank bottom produced by the pneumatic test of the outer tank; as an alternative, the pressure between the inner and outer tanks can be equalized.

Q.9.2.2 Air pressure shall be applied to the space enclosed by the outer tank equal to at least the design gas pressure but not exceeding a pressure that would overstress either the inner or outer tank.

Q.9.2.3 While the test pressure is being held, all welded seams and connections in the outer shell and roof shall be thoroughly inspected with a solution film unless they were previously checked with a vacuum box.

Q.9.2.4 The air pressure shall be released.

Q.9.2.5 Pressure relief and vacuum relief valves shall be checked by applying the design gas pressure to the outer tank, followed by evacuation of the outer space to the vacuum setting of the relief valve.

Q.10 Foundations

Q.10.1 GENERAL

Appendix C describes the factors involved in obtaining adequate foundations for tanks that operate at atmospheric temperature. The foundations for refrigerated tanks are complicated because of the thermal movement of the tank, the insulation required for the bottom, the effects of foundation freezing and possible frost heaving, and the anchorage required to resist uplift.

The services of a qualified foundation engineer are essential. Experience with tanks in the area may provide sufficient data, but normally a thorough investigation, including soil tests, would be required for proper design of the foundation.

Q.10.2 BEARING ON FOUNDATIONS

Foundations shall preferably be designed to resist the load exerted by the tank and its contents when the tank is filled with water to the design liquid level. Foundations shall be designed at least for the maximum operating conditions including the wind load. During the water test, the total load on the foundation shall not exceed 125% of the allowable loading. If necessary, the water level during the test may be reduced below the design liquid level line so as not to exceed the 25% maximum overload (see Q.8.1.2).

Q.10.3 UPLIFTING FORCE AND DOWNWARD WEIGHTS

The uplifting force to be considered in designing the ring-wall or concrete pad foundation may be offset by the coexistent downward weights and forces, including the metal and insulation weight of the shell and roof and the concrete and earth weight transmitted by the anchorage to the shell. The tank shall be assumed to be empty of liquid.

Q.10.4 UPLIFT ON FOUNDATION

Q.10.4.1 The increased uplift described in Q.10.4.2 and Q.10.4.3 is intended to apply to the size of the ringwall and foundation but not the anchorage.

Q.10.4.2 For tanks with an internal design pressure less than 1 lbf/in.² gauge, the uplift shall be taken as the smaller of the maximum uplift values computed under the following conditions:

- The internal design pressure times 1.5 plus the design wind load on the shell and roof.
- The internal design pressure plus 0.25 lbf/in.² gauge plus the design wind load on the shell and roof.

Q.10.4.3 For tanks with an internal design pressure of 1 lbf/in.² gauge and over, the uplift, if any, shall be calculated under the combined conditions of 1.25 times the internal design condition plus the design wind load on the shell and roof.

Q.10.4.4 When the anchorage is designed to meet the requirements of Q.3.6.4.2, the foundation should be designed to resist the uplift that results from three times the design pressure with the tank full to the design liquid level. When designing to any of the conditions in this paragraph, it is permissible to utilize friction between the soil and the vertical face of the ringwall and all of the effective liquid weight.

Q.11 Marking

Q.11.1 DATA ON NAMEPLATE

The data required to be marked on the tank by the manufacturer is listed in 8.1 and shall indicate that the tank has been constructed in accordance with Appendix Q.

Q.11.2 LOCATION OF NAMEPLATE

In addition to the requirements of 8.1, the nameplate shall be attached to the tank at an accessible location if it is outside of any insulation or protective covering of the tank. The nameplate for the inner tank shall be located on the outer tank wall but shall refer to the inner tank. The nameplate, if any, for the outer tank of a double-wall tank shall be located adjacent to the nameplate or the inner tank and shall refer to the outer tank.

Q.12 Reference Standards

For rules and requirements not covered in this appendix or in the basic rules of this standard, the following documents should be referred to for the type of material used in the tank:

- For 9% and 5% nickel steels, Part UHT in Section VIII of the ASME Code.
- For stainless steel, Part UHA in Section VIII of the ASME Code.
- For aluminum, Part UNF in Section VIII of the ASME Code and ASME B96.1.

**For Committee
Use Only**

APPENDIX R—LOW-PRESSURE STORAGE TANKS FOR REFRIGERATED PRODUCTS

R.1 Scope

R.1.1 GENERAL

The provisions in this appendix form a guide for the materials, design, and fabrication of tanks to be used for the storage of refrigerated products.

The requirements for a basic API Std 620 tank are superseded by any requirements of this appendix; all other requirements for an API Std 620 tank shall apply.

A refrigerated tank may be a single-wall insulated tank or a double-wall tank that consists of an inner tank for storing the refrigerated liquid and an outer tank that encloses an insulation space (which usually has a lower gas pressure) around the inner tank. A double-wall tank is a composite tank, and the outer tank is not required to contain the product of the inner tank. In a double-wall tank, differences in materials, design, and testing exist between the inner and outer tanks.

R.1.2 PRESSURE RANGE

The provisions in this appendix apply to all design pressures within the scope of this standard.

R.1.3 TEMPERATURE RANGE

The provisions in this appendix are considered suitable for design metal temperatures from + 40°F to – 60°F, inclusive.

R.1.4 PRIMARY COMPONENTS

R.1.4.1 In general, primary components include those components whose failure would result in leakage of the liquid being stored, those exposed to the refrigerated temperature, and those subject to thermal shock. Further definitions of such components are provided in R.1.4.2 and R.1.4.3.

R.1.4.2 The primary components shall include, but will not be limited to, the following parts of a single-wall tank or of the inner tank in a double-wall tank: shell plates; bottom plates; knuckle plates; compression rings; and shell manways and nozzles including reinforcement, shell anchors, piping, tubing, forgings, and bolting. Roof nozzles in contact with the refrigerated liquid shall be considered primary components.

R.1.4.3 The primary components shall also include those parts of a single-wall or an inner tank that are not in contact with the refrigerated liquid but are subject to the refrigerated temperature. Such components include roof plates, roof manways and nozzles with their reinforcements, roof-supporting structural members, and shell stiffeners when the combined tensile and primary bending stresses in these components under design conditions are greater than 6000 lbf/in.².

R.1.5 SECONDARY COMPONENTS

Secondary components are those whose failure would not result in leakage of the liquid being stored. Secondary components also include those components that are not in contact with the refrigerated liquid but are subject to the refrigerated temperature vapors and have a combined tensile and primary bending stress under design conditions that does not exceed 6000 lbf/in.². Secondary components that could be designed within this reduced stress are roof plates, including roof manways and nozzles with their reinforcement, roof-supporting structural members, and shell stiffeners.

R.1.6 BASIC COMPONENTS

Basic components are those that contain the vaporized liquefied gas from the stored refrigerated liquid but primarily operate at atmospheric temperatures because of insulation system design and natural ambient heating. These components shall comply with the basic rules of this standard. Examples of such components are the outer wall and roofs of double-wall tanks and roof components above an internally insulated suspended deck.

R.2 Materials

The materials requirements are based on the storage of refrigerated products at the design metal temperature.

R.2.1 PRIMARY COMPONENTS

R.2.1.1 General

Materials for primary components shall comply with the requirements of Tables R-1 and R-2. All primary components shall be impact tested in accordance with R.2.1.2 through R.2.1.4.

R.2.1.2 Impact Test Requirements for Plates

R.2.1.2.1 Impact testing of plates, including structural members made of plate, shall comply with Table R-1.

R.2.1.2.2 Impact test specimens shall be taken transverse to the direction of final plate rolling.

R.2.1.2.3 The Charpy V-notch test shall be used, and the minimum impact value at the design metal temperature shall be as given in Table R-2. For subsize specimen acceptance criteria, see ASTM A 20. An impact test temperature lower than the design metal temperature may be used by the manufacturer, but in such a case the impact values at the test temperature must comply with Table R-2.

Table R-1—Material for Primary Components

Component	Materials	Notes
Plate	Refer to R.2.1.2	1 and 2
Pipe	ASTM A 333 (seamless only)	2 and 3
Structural members	Plate or pipe as listed above	4
	Structural shapes	5
	ASTM A 36 Mod 1	6
	ASTM A 131 Grades CS, D, and E	
	ASTM A 633 Grade A	
	CSA G40.21 Grades 38WT, 44WT and 50WT	
Forgings	ASTM A350	2 and 3
Bolts	ASTM A 320 Grade L7	3

Notes:

1. See R.2.1.4.
2. Type 304 or 304L stainless steel material, as permitted in Table Q-1 may be used at the maximum allowable stress values permitted by Table Q-3. Impact tests of this material are not required. Welding procedures shall be qualified in accordance with the more restrictive requirements of R.6.1 and Q.6.3 as applicable to the base materials and welding material.
3. See R.2.1.3.
4. See R.2.1.5.
5. Normalized, if necessary, to meet the required minimum Charpy V-notch impact values.
6. See 4.5 for a complete description of this material.

R.2.1.2.4 All other impact requirements of ASTM A 20, Supplementary Requirement S 5, shall apply for all materials listed in Table R-2, including specifications that do not refer to ASTM A 20.

R.2.1.2.5 When as-rolled plate material complies with impact test requirements as specified here, the material need not be normalized. If, as with ASTM A 516, the specification prohibits impact test without normalizing but otherwise permits as-rolled plates, the material may be ordered in accordance with the above provision and identified as “MOD” for this API modification.

R.2.1.3 Impact Requirements for Pipe, Bolting, and Forgings

The impact tests for pipe (including structural members made of pipe), bolting, and forgings, shall be in accordance with ASTM specifications referred to in Table R-1.

Piping materials made according to ASTM A 333 and A 350 may be used at design metal temperatures no lower than the impact test temperature required by the ASTM specification for the applicable material grade without additional

impact tests. For temperatures below those allowed by the ASTM specification, the following paragraph shall apply.

For all other materials, the impact test temperature shall be at least 30°F colder than the design metal temperature. Alternately, materials impact tested at the design metal temperature or lower with Charpy impact test energy value of 25 ft-lbs (average), 20 ft-lbs (minimum) are acceptable for design metal temperatures above – 40°F. Materials with an energy value of 30 ft-lbs (average), 25 ft-lbs (minimum) are acceptable for design metal temperatures of – 40°F or lower.

R.2.1.4 Impact Requirements for Controlled-Rolled or Thermo-Mechanical Control Process (TMCP) Plates

Subject to the approval of the purchaser, controlled-rolled or TMCP plates (material produced by a mechanical-thermal rolling process designed to enhance the notch toughness) may be used where normalized plates are required. Each plate, as rolled, shall be Charpy V-notch tested to the requirements of R.2.1.2.

R.2.1.5 Impact Requirements for Structural Shapes

Impact test for structural shapes listed in Table R-1 shall be made in accordance with ASTM A 673 on a piece-testing frequency. Impact values, in foot-pounds, shall be 25 minimum average of 3 and 20 minimum individual at a temperature no warmer than the design metal temperature.

R.2.2 BASIC AND SECONDARY COMPONENTS

Materials for basic and secondary components shall comply with R.2.2.1 and R.2.2.2.

R.2.2.1 Material for the outer tank and for the roof that contains the vaporized liquefied gas but is primarily subjected to atmospheric temperatures may conform to one of the following:

- a. Table 4-1 for design metal temperatures down to – 35°F (lowest 1-day mean ambient temperature of – 35°F) without impact test unless they are required by Table 4-1 or by the purchaser.
- b. Table R-3 for design metal temperatures down to – 60°F without impact tests unless they are required by Table R-4 or by the purchaser.
- c. If approved by the purchaser, the material may be selected by the requirements of 4.2.2.

R.2.2.2 Material for the outer tank that does not contain the vaporized liquefied gas may conform to any of the approved materials listed in Table 4-1. Consideration of the design metal temperature is not required if the actual stress in the outer tank does not exceed one-half the allowable tensile design stress for the material.

Table R-2—Minimum Charpy V-Notch Impact^a Requirements for Primary-Component Plate Specimens (Transverse) and Weld Specimens Including the Heat-Affected Zone

Specification Number	Grade	Range in Thickness (in.)	Plate Impact Value ^b (ft-lb)		Weld Impact Value (ft-lb)	
			Average	Individual	Average	Individual
ASTM A 131	Cs ^c	$3/16 - 1\frac{1}{2}$	25	20	20	15
ASTM A 516	55 and 60	$3/16 - 2$	25	20	20	15
ASTM A 516	65 and 70	$3/16 - 2$	25	20	20	15
ASTM A 516	65 and 70 Mod 1 ^d	$3/16 - 2$	25	20	20	15
ASTM A 516	65 and 70 Mod 2 ^d	$3/16 - 2$	25	20	20	15
ASTM A 841	1	$3/16 - 2$	25	20	20	15
ASTM A 537	1	$3/16 - 2$	25	20	20	15
ASTM A 537	2	$3/16 - 2$	30	25	25	20
ASTM A 662	B and C	$3/16 - 2$	25	20	20	15
ASTM A 678	A ^c	$3/16 - 1\frac{1}{2}$	25	20	20	15
ASTM A 678	B ^c	$3/16 - 2$	30	25	25	20
ASTM A 737	B	$3/16 - 2$	25	20	20	15
ASTM A 841	1	$3/16 - 2$	25	20	20	15
ISO 630	E 355 Quality D ^{c,d,e}	$3/16 - 2$	25	20	20	15
CSA G40.21	38WT ^{c,d,e}	$3/16 - 2$	25	20	20	15
CSA G40.21	44WT ^{c,d,e}	$3/16 - 2$	25	20	20	15
CSA G40.21	50wt ^{c,d,e}	$3/16 - 2$	25	20	20	15

Notes:

^aSee R.2.1.2.^bFor design metal temperatures of -40°F and lower, the plate impact values shall be raised 5 ft-lb.^cThe frequencies of testing for mechanical and chemical properties shall be at least equal to those of ASTM A 20.^dSee 4.2.3 for a complete description of this material.^eThe steel shall be fully killed and made with fine-grain practice.

Table R-3—Material for Secondary Components

Material	Design Metal Temperature of Secondary Components	
	-60°F to Below -20°F	-20°F to $+40^{\circ}\text{F}$
Plate	Materials as listed in Table R-4	Materials as listed in Table R-4
Pipe	ASTM A 106	As listed in 4.3
Structural members	Plate or pipe as listed above	Plate or pipe as listed above
	ASTM A 36 Mod 1 structural shapes (see 4.5)	Structural shapes as listed in 4.5 or as listed under the -60°F to -20°F temperature heading
	ASTM A 131 Grade CS CSA G40.21 Grades 38W, 44W, and 50W (see Note)	—
Forgings	ASTM A 105	As listed in 4.3
Bolts	ASTM A 193 Grade B7	As listed in 4.4
	ASTM A 320 Grade L7	

Note: The steel shall be fully killed and made to fine-grain practice.

Table R-4—Minimum Permissible Design Metal Temperature for Plates Used as Secondary Components Without Impact Testing

Group	Specification Number	Grade	Minimum Design Metal Temperature, °F			
			Plate Thickness Including Corrosion Allowance, in.			
			$3/16$ – $3/8$	$> 3/8$ – $1/2$	$> 1/2$ – 1	> 1 – $1\frac{1}{2}$
04 I (semikilled)	A 36	Mod 2 ^a	–20	–10	+5	—
	A 131	B	–20	–10	+5	—
	CSA G40.21	38W	0	+10	+25	—
	ISO 630	E 275 Quality C ^b	–20	–10	+5	+5
04 II (fully killed)	A 573	58 ^b	–30	–20	–10	0
	A 131	CS	–60	–50	–35	–20
	A 516	55 and 60	–30	–20	–10	0
	A 516	55 and 60 ^c	–40	–30	—	—
	ISO 630	E 275 Quality D ^b	–30	–20	–10	0
	CSA G40.21	38W ^b	–40	–30	–15	0
04 III (fully killed and high strength)	A 573	65 and 70	–30	–20	–10	+5
	A 516	65 and 70	–30	–20	–10	+5
	A 516	65 and 70 Mod 1 ^a	–40	–30	–15	0
	A 537	1 and 2	–60	–50	–35	–20
	A 662	B and C	–40	–30	–15	0
	A 633	C and D	–60	–50	–35	–20
	A 678	A and B	–60	–50	–35	–20
	A 737	B	–60	–50	–35	–20
	ISO 630	E 355 Quality D ^b	–30	–20	–10	+5
	CSA G40.21	44W ^b	–40	–30	–15	0
	CSA G40.21	50W ^b	–30	–10	+5	+20

Notes:

When normalized, materials in this table may be used at temperatures 20°F below those shown (except for A 131 Grade CS, A 537 Classes 1 and 2, A 633 Grades C and D, A 678 Grades A and B, and A 737 Grade B). If impact tests are required for the materials listed in this table, they shall be in accordance with Table R-5.

^aSee 4.2.3 for a complete description of this material.

^bThe steel shall be fully killed and made with fine-grain practice, without normalizing, for thicknesses of $3/16$ in. through $1\frac{1}{2}$ in.

^cThe manganese content shall be in the range from 0.85% to 1.20% by ladle analysis.

R.3 Design

R.3.1 WEIGHT OF LIQUID STORED

The weight of the liquid stored shall be assumed to be the maximum weight per cubic foot of the specified liquid within the range of operating temperatures, but in no case shall the assumed minimum weight be less than 36 lb/ft³.

R.3.2 DESIGN METAL TEMPERATURE

The design metal temperature of each component exposed to the liquid or vapor being stored shall be the lower of the following:

a. The minimum temperature to which the tank contents will be refrigerated, including the effect of subcooling at reduced pressure.

b. The minimum metal temperature anticipated when the atmospheric temperature is below the refrigerated temperature (see 4.2.1). The effectiveness of the insulation in keeping the metal temperature above the expected minimum atmospheric temperature shall be considered.

R.3.3 DESIGN ALLOWABLE STRESS

The maximum allowable tensile stress shall be taken from Table 5-1 or Table Q-3. For the maximum allowable stresses for design loadings combined with wind or earthquake loads, see 5.5.6 for carbon steel and Q.3.3.5 for stainless steel and aluminum.

R.3.4 ANNULAR BOTTOM PLATES

R.3.4.1 The tank shell that contains the liquid shall have butt-welded annular bottom plates with a radial width that

provides at least 24 in. between the inside of the shell and any lap-welded joint in the remainder of the bottom and at least a 2-in. projection outside the shell. A greater radial width (L_{min}) of annular plate is required when calculated by the following equation:

$$L_{min} = \frac{390t_b}{\sqrt{(H)(G)}}$$

where

- t_b = nominal thickness of the annular plate, in in.,
- H = maximum height of the liquid, in ft,
- G = design specific gravity of the liquid to be stored.

R.3.4.2 The thickness of the annular bottom plates shall be not less than the thicknesses listed in Table R-6.

R.3.4.3 The ring of annular plates shall have a circular outside circumference, but may have a regular polygonal shape inside the tank shell with the number of sides equal to the number of annular plates. These pieces shall be butt-welded in accordance with R.7.1.1, item b.

R.3.4.4 The plates of the first shell course shall be attached to the annular bottom plates by welds as required by 5.9.5

except when a full penetration weld is used or required (see R.7.1.1).

R.3.4.5 Butt-welds in annular plates shall be not closer than 12 in. from any vertical weld in the tank shell.

R.3.4.6 Three-plate laps or butt-weld junctions in the tank bottom shall be not closer than 12 in. from each other and/or the butt-welds of the annular plate.

R.3.5 SHELL STIFFENING RINGS FOR TANKS THAT CONTAIN LIQUID

R.3.5.1 Internal or external shell stiffening rings may be required to maintain roundness when the tank is subjected to wind, vacuum, or other specified loads. When stiffening rings are required, the stiffener-to-shell weld details shall be in accordance with Figure R-1 and R.3.5.2 through R.3.5.5.

R.3.5.2 The stiffener ring and backing strip, if used, are primary components, and they shall comply with the requirements of R.2.1. The stiffener ring may be fabricated from plate using an intermittent weld on alternating sides between the web and the flange.

R.3.5.3 One rat hole with a minimum radius of $3/4$ in. shall be provided at each longitudinal shell joint and ring juncture weld (see Figure R-1).

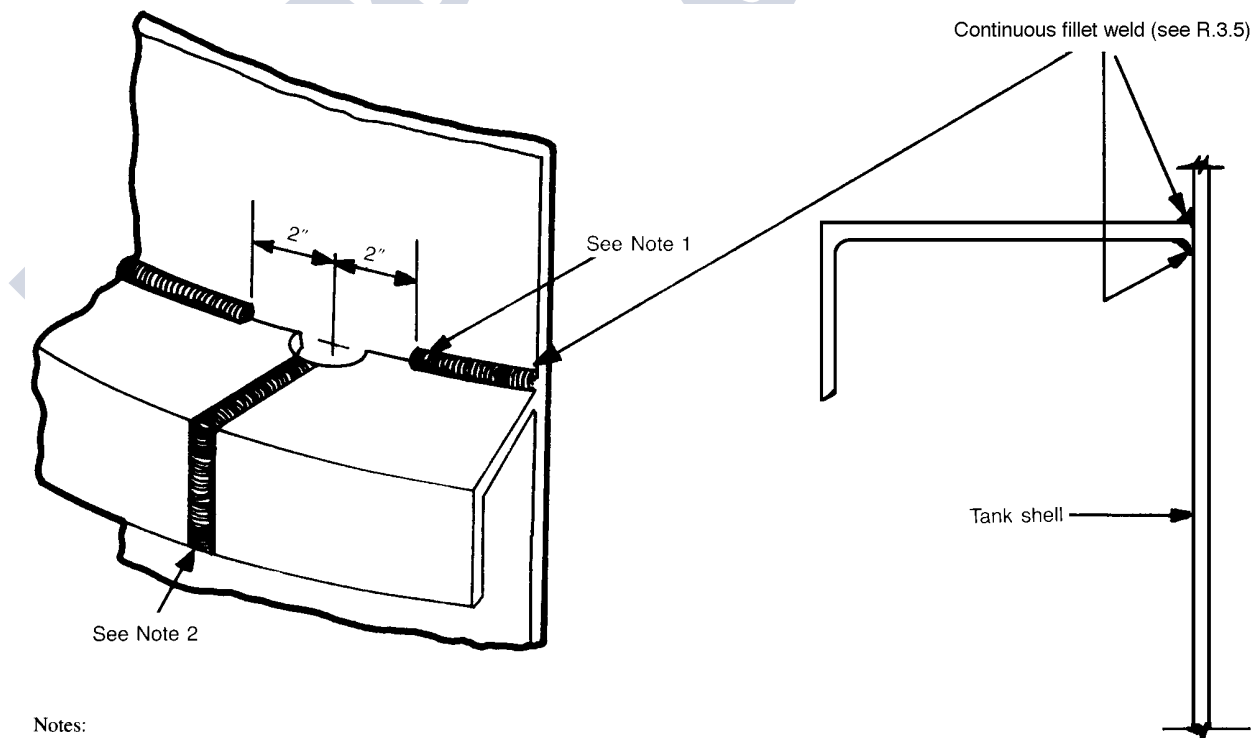

Notes:

1. See R.3.5.4 for alternative fillet-weld termination details.
2. Backing strips are permitted for stiffening-ring junction welds.

Figure R-1—Typical Stiffening-Ring Weld Details

R.3.5.4 All fillet welds shall consist of a minimum of two passes. The ends of the fillet welds shall be 2 in. from the rat hole (see Figure R-1), and these welds shall be deposited by starting 2 in. from the rat hole and welding away from the rat hole. An acceptable alternative to stopping fillet welds 2 in. short of the rat hole would be to weld continuously through the rat hole from one side of the stiffener to the opposite side. All craters in fillet welds shall be required by back welding.

R.3.5.5 Any joints between the adjacent sections of stiffening rings, as shown in Figure R-1, shall be made so that the required moment of inertia of the combined ring-shell section is provided. Weld joints between adjacent sections shall be made with full-thickness and full-penetration butt-welds. Stiffening-ring butt-welds may employ metal backing strips. Backing strips and the associated welding shall be made in a manner that provides a smooth contour in the rat hole and all other weld joint ends. All weld passes shall be started at the rat hole and other weld joint ends and shall be completed by moving away from these ends. Passes shall be overlapped away from the edge to provide a smooth continuous weld.

R.3.6 TANK ANCHORAGE

R.3.6.1 In addition to the loads in R.4, R.5.1, and R.5.2, the anchorage for the tank that contains liquid, whether it be a single-wall tank or the inner tank of a double-wall tank, shall be designed to meet the requirements of R.3.6.2 through R.3.6.5.

R.3.6.2 The anchorage shall accommodate movement of the tank wall and bottom caused by thermal changes.

R.3.6.3 The manufacturer and the purchaser should consider using stainless steel anchorage materials, or they should provide for corrosion allowance when carbon steels are used. Material for tank anchorage shall meet the requirements for primary components given in R.2.1.

R.3.6.4 For anchored flat-bottom tanks, the anchorage shall be designed as described in R.3.6.4.1 through R.3.6.4.3.

R.3.6.4.1 When the topshell course is the minimum thickness indicated in 5.10.4 and Figure 5-6, details a – e, h, and i, the minimum anchorage shall be designed for normal loads as specified by the purchaser and by this standard. See 5.11.2.3 for the allowable stress.

R.3.6.4.2 When the topshell course is thickened as in Figure 5-6, details f and g, or when a knuckle is used, the minimum anchorage shall be designed for three times the internal design pressure. The allowable stress for this loading is 90% of the minimum specified yield strength of the anchorage material.

R.3.6.4.3 As an alternative to R.3.6.4.2, the purchaser may specify a combination of normal anchorage design (see R.3.6.4.1) and emergency venting.

R.3.6.5 The foundation design loading for R.3.6.4 is described in R.10.5.3.

R.4 Design of a Single-Wall Tank

The purchaser shall specify the design metal temperature and pressures (internal and external), specific gravity of the contents to be stored, roof live load, wind load, earthquake load where applicable, and corrosion allowance, if any. The insulation load shall be considered.

R.5 Design of a Double-Wall Tank

R.5.1 DESIGN SPECIFICATIONS

The outer bottom, shell, and roof of a double-wall tank shall enclose an insulating space around the bottom, shell, and roof of the inner tank that contains the stored liquid. The annular space shall be maintained at a low positive pressure, which necessitates that the enclosure be vapor-tight. The purchaser shall specify the design metal temperature and pressures (internal and external) of both the inner and outer tanks, specific gravity of the contents to be stored, roof live load, wind load, earthquake load where applicable, and corrosion allowance, if any. The static insulation pressure and pressures from expansion and contraction of the insulation shall be considered.

R.5.2 COMBINATION OF DESIGN LOADS

The inner tank shall be designed for the most critical combinations of loading that result from internal pressure and liquid head, the static insulation pressure, the insulation pressure as the inner tank expands after an in-service period, and the purging or operating pressure of the space between the inner and outer tank shells. The outer wall shall be designed for the purging and operating pressure of the space between the inner and outer tank shells and for the loading for insulation, the pressure of wind forces, and roof loading.

R.5.3 OUTER TANK

R.5.3.1 The outer tank bottom, shell, and roof shall be a minimum nominal thickness of $\frac{3}{16}$ in. (7.65 lb/ft²).

R.5.3.2 The outer tank bottom, shell, and roof not in contact with the vaporized liquefied gas may be of single-welded lap or of single-welded butt construction when the thickness does not exceed $\frac{3}{8}$ in.; or, at any thickness, it may be of double-welded butt construction without necessarily having full fusion and penetration. Single-welded joints shall be welded from the outside to prevent corrosion and the entrance of moisture.

R.5.3.3 When in contact with the vaporized liquefied gas, the outer tank bottom, shell, and roof shall conform to the lap- or butt-welded construction described elsewhere in this standard.

Table R-5—Minimum Charpy V-Notch Impact Requirements for Secondary-Component Plate Specimens (Transverse)

Group	Specification Number	Grade	Range in Thickness (in.)	Impact Value ^a (foot-lbs)	
				Average	Individual
I (semikilled)	A 36	Mod 2 ^b	$\frac{3}{16}$ – 1	13	9
	A 131	B	$\frac{3}{16}$ – 1	13	9
	ISO 630	Fe 430 Quality C	$\frac{3}{16}$ – 1 $\frac{1}{2}$	13	9
II (fully killed)	A 573	58 ^c	$\frac{3}{16}$ – 1 $\frac{1}{2}$	15	10
	A 131	CS	$\frac{3}{16}$ – 1 $\frac{1}{2}$	15	10
	A 516	55 and 60	$\frac{3}{16}$ – 2	15	10
	A 516	55 and 60 ^d	$\frac{3}{16}$ – 1 $\frac{1}{2}$	15	10
	ISO 630	Fe 430 Quality D ^c	$\frac{3}{16}$ – 1 $\frac{1}{2}$	15	10
	CSA G40.21	38WT	$\frac{3}{16}$ – 2	15	10
III (fully killed and high strength)	A 573	65 and 70	$\frac{3}{16}$ – 2	15	10
	A 516	65 and 70	$\frac{3}{16}$ – 2	15	10
	A 516	65 and 70 Mod 1 ^b	$\frac{3}{16}$ – 2	15	10
	A 516	65 and 70 Mod 2 ^b	$\frac{3}{16}$ – 2	15	10
	A 537	1	$\frac{3}{16}$ – 2	15	10
	A 537	2	$\frac{3}{16}$ – 2	20	15
	A 633	C and D	$\frac{3}{16}$ – 2	15	10
	A 662	B	$\frac{3}{16}$ – 2	15	10
	A 678	A	$\frac{3}{16}$ – 1 $\frac{1}{2}$	20	15
	A 678	B	$\frac{3}{16}$ – 2	20	15
	ISO 630	Fe 52 Quality D ^c	$\frac{3}{16}$ – 2	15	10
	CSA G40.21	44WT	$\frac{3}{16}$ – 2	15	10
	A 841	1	$\frac{3}{16}$ – 2	15	10

Notes:

^aThe stated values apply to full-sized specimens. For sub-size specimen acceptance criteria, see ASTM A 20. An impact test temperature lower than the design metal temperature may be used by the manufacturer, but the impact values at the test temperature must comply with Table R-5. When plate is selected, consideration must be given to the possible degradation of the impact properties of the plate in the weld heat-affected zone.

^bSee 4.2.3 for a complete description of this material.

^cThe steel shall be fully killed and made with fine-grain practice, without normalizing, for thicknesses of $\frac{3}{16}$ in. – 1 $\frac{1}{2}$ in.

^dThe manganese content shall be in the range from 0.85% to 1.20% by ladle analysis.

R.6 Welding Procedures

These rules shall apply only to the primary components of the tank. The secondary components shall be welded in accordance with the basic rules of this standard.

R.6.1 WELDING PROCEDURE QUALIFICATION

R.6.1.1 The qualification of welding procedures shall conform to 6.7. For primary components (see R.2.1), impact tests are also required for each welding procedure (with exceptions for Type 304 or 304L stainless steel described in Table R-1, Note 2). Charpy V-notch specimens that conform to ASTM E 23 shall be taken from the weld metal and from the heat-

affected zone of the welding procedure qualification test plates or duplicate test plates.

R.6.1.2 Weld metal impact specimens shall be taken across the weld with the notch in the weld metal. The specimen shall be oriented so that the notch is normal to the surface of the material. One face of the specimen shall be substantially parallel to and within $\frac{1}{16}$ in. of the surface.

R.6.1.3 Heat-affected-zone impact specimens shall be taken across the weld and as near the surface of the material as is practicable. The specimens shall be of sufficient length to locate, after etching, the notch in the heat-affected zone. The notch shall be cut approximately normal to the material surface to include as much heat-affected zone material as possible in the resulting fracture.

Table R-6—Thickness Requirements^a for the Annular Bottom Plate

Nominal Thickness of First Shell Course (in.)	Design Stress ^b in First Shell Course (lb/in. ²)			
	≤ 20,000	22,000	24,000	26,000
≤ 0.75	1/4	1/4	1/4	1/4
> 0.75 – 1.00	1/4	1/4	1/4	5/16
> 1.00 – 1.25	1/4	1/4	5/16	3/8
> 1.25 – 1.50	1/4	9/32	3/8	7/16

Notes:

^aThe thicknesses and width (see R.3.4.1) are based on the foundation providing a uniform support under the full width of the annular plate. Unless the foundation is properly compacted, particularly at the inside of a concrete ringwall, settlement will produce additional stresses in the annular plate.

^bThe stress shall be calculated using the formula $(2.6D)(HG)/t$, where D = nominal diameter of the tank, in ft; H = maximum filling height of the tank for design, in ft; G = design specific gravity; and t = design thickness of the first shell course, excluding corrosion allowance, in.

R.6.1.4 Impact test specimens shall be tested at the design metal temperature or at a lower temperature, as agreed upon by the purchaser and the manufacturer.

R.6.1.5 The required impact values of the weld and heat-affected zone shall be as given in Table R-2.

R.6.2 PRODUCTION WELDING PROCEDURES

The production welding procedures and the production welding shall conform to the requirements of the procedure qualification tests within the following limitations:

- Individual weld layer thickness shall not be substantially greater than that used in the procedure qualification test.
- Electrodes shall be of the same size and American Welding Society (AWS) classification.
- The nominal preheat and interpass temperatures shall be the same.

R.6.3 PRODUCTION WELD TESTS

R.6.3.1 Production weld test plates shall be welded and tested for primary-component, butt-welded shell plates when welding procedure qualifications are required to be impact tested per paragraph R.6.1.1. The number of production weld tests shall be based on the requirements of R.6.3.3 and R.6.3.4. Weld testing shall be in accordance with R.6.3.5. Test plates shall be made from plates produced only from the heats used to produce the shell plates for the tank.

R.6.3.2 Test plates shall be welded using the same qualified welding procedure and electrodes as required for the tank shell plate joints. The test plates need not be welded as an extension of the tank shell joint but shall be welded in the required qualifying positions and essential variables.

R.6.3.3 One test weld shall be made on a set of plates from each specification and grade of plate material, using a thickness that would qualify for all thicknesses in the shell. Each test welded of thickness t shall qualify for plate thicknesses from $2t$ down to $t/2$, but not less than $5/8$ in. For plate thicknesses less than $5/8$ in., a test weld shall be made for the thinnest shell plate to be welded; this test weld will qualify the plate thickness from t up to $2t$.

R.6.3.4 Test welds shall be made for each position and for each process used in welding the tank shell, but a manual vertical test weld will qualify manual welding of all positions. Test welds are not required for machine welded circumferential joints in cylindrical shells.

R.6.3.5 The impact specimens and testing procedure shall conform to R.6.1.2 through R.6.1.5.

R.6.3.6 By agreement between the purchaser and the manufacturer, production weld test plates for the first tank shall satisfy the requirements of this paragraph for similar tanks at the same location if the tanks are fabricated within six months of the time the impact tests were made and found satisfactory.

R.7 Requirements for Fabrication, Openings, and Inspection

R.7.1 WELDING OF PRIMARY COMPONENTS

R.7.1.1 The following primary components shall be joined with double butt-welds that have complete penetration and complete fusion except as noted:

- Longitudinal and circumferential shell joints.
- Joints that connect the annular bottom plates together.

- c. Joints that connect sections of compression rings and sections of shell stiffeners together. Back-up bars may be used for these joints with complete penetration and complete fusion details.
- d. Joints around the periphery of an insert plate.
- e. Joints that connect the shell to the bottom, unless a method of leak checking is used (see R.8.2.3); in that case, double fillet welds are acceptable.
- f. Joints that connect nozzle and manhole necks to flanges.
- g. Butt-welds in piping nozzles, manway necks, and pipe fittings, including weld neck flanges, shall be made using double butt-welded joints. When accessibility does not permit the use of double butt-welded joints, single butt-welded joints that ensure full penetration through the root of the joint are permitted.

R.7.1.2 All primary components joined together by fillet welds shall have a minimum of two passes.

R.7.1.3 Slip-on flanges may be used where specifically approved by the purchaser.

R.7.2 WELDING OF CONNECTIONS IN PRIMARY COMPONENTS

All opening connections located in primary components shall have complete penetration and complete fusion. Acceptable types of welded opening connections are shown in Figure 5-8, panels a, b, c, g, h, m, and o.

R.7.3 POSTWELD HEAT TREATMENT

R.7.3.1 In primary components, all opening connections shall be welded into the shell plate or a thickened insert plate, and the welded assembly shall be stress relieved prior to installation in the tank unless one of the following exceptions is fulfilled:

- a. The stress level in the plate, under the design conditions, does not exceed 10% of the minimum tensile strength of the plate material. The opening shall be reinforced for the low stress.
- b. The impact tests on the material and welding fulfill the requirements of R.2.1.2 and Table R-2, and the thickness of the material is less than $\frac{5}{8}$ in. for any diameter of connection or less than $1\frac{1}{4}$ in. for connections that have a nominal diameter less than 12 in. The thickness of the nozzle neck without stress relief shall be limited to the value of $(D + 50)/120$, as described in 5.25.3.
- c. Opening reinforcement is made from forgings similar in configuration to Figure 5-8, panels o-1, o-2, o-3, and o-4.

R.7.3.2 The stress-relieving requirements of 5.25 shall still be mandatory for both primary and secondary components.

R.7.3.3 When used in stress relieved assemblies, the material of TMCP steel A 841 shall be represented by test specimens that have been subjected to the same heat treatment as that used for the stress relieved assembly.

R.7.4 SPACING OF CONNECTIONS AND WELDS

In primary components, all opening connections in a shell plate shall conform to the requirements of R.7.4.1 through R.7.4.3 for the spacing of butt and fillet welds.

R.7.4.1 The butt-weld around the periphery of a thickened insert plate or the fillet weld around the periphery of a reinforcing plate shall be at least the greater of 10 times the shell thickness or 12 in. from any butt-welded shell seams except where the completed periphery weld has been stress relieved prior to the welding of the adjacent butt-welded shell seams. Where stress relief has been performed, the spacing from the periphery weld to a shell butt-weld shall be at least 6 in. from the longitudinal or meridional joints or 3 in. from the circumferential or latitudinal joints if in either case the spacing is not less than 3 times the shell thickness. These rules shall also apply to the bottom-to-shell joint; however, as an alternative, the insert plate or reinforcing plate may extend to and intersect the bottom-to-shell joint at approximately 90°. The stress-relieving requirements do not apply to the weld to the bottom or annular plate.

R.7.4.2 In cylindrical tank walls, the longitudinal weld joints in adjacent shell courses, including compression ring welds, shall be offset from each other a minimum distance of 12 in.

R.7.4.3 Radial weld joints in a compression ring shall not be closer than 12 in. from any vertical weld.

R.7.5 INSPECTION OF WELDS BY MAGNETIC-PARTICLE OR LIQUID-PENETRANT METHODS

The following primary-component welds shall be inspected, using the magnetic-particle method (see 7.15) for carbon steel and the liquid-penetrant method (see 7.15) for stainless steel, after stress relieving, if any, and before the hydrostatic test of the tank.

- a. All longitudinal and circumferential butt-welds that are not completely radiographed. Inspection shall be on both sides of the joint.
- b. The welded joint that joins the cylindrical wall of the tank to the bottom annular plates.
- c. All welds of opening connections that are not completely radiographed, including nozzle and manhole neck welds and neck-to-flange welds. Inspection shall also include the root pass and every $\frac{1}{2}$ in. of thickness of deposited weld metal (see 5.27.11) as welding progresses.

d. All welds of attachments to primary components such as stiffeners, compression rings, clips, and other nonpressure parts.

e. All welded joints on which backing strips are to remain shall also be examined after the first two layers (or beads) of weld metal have been deposited.

04 | **R.7.6 RADIOGRAPHIC/ULTRASONIC EXAMINATION OF BUTT-WELDS IN PLATES**

Primary-component butt-welds shall be examined by radiographic or ultrasonic methods. When the term “examination” is used in section R.7.6 and its subsections, it shall be understood to refer to radiographic or ultrasonic examination. 04 | The extent of the examination shall be as described in R.7.6.1 through R.7.6.6. When the examination is by the ultrasonic method, it shall be done in accordance with the requirements of Appendix U.

R.7.6.1 Butt-welds in all tank wall courses subjected to a maximum actual operating membrane tensile stress perpendicular to the welded joint that is greater than 0.1 times the specified minimum tensile strength of the plate material shall be completely examined. 04 |

R.7.6.2 Butt-welds in all tank wall courses subjected to a maximum actual operating membrane tensile stress perpendicular to the welded joint that is less than or equal to 0.1 times the specified minimum tensile strength of the plate material shall be examined in accordance with Figure R-2. 04 |

R.7.6.3 Butt-welds around the periphery of a thickened insert plate shall be completely examined. This does not include the weld that joins the insert plate with the bottom plate of a flat-bottom tank. 04 |

R.7.6.4 Butt-welds at all three-plate junctions in the tank wall shall be examined except in the case of a flat bottom (wall) supported uniformly by the foundation. This does not include the shell-to-bottom weld of a flat-bottom tank. See 04 | Figure R-2 for minimum examination dimensions.

R.7.6.5 Twenty-five percent of the butt-welded annular plate radial joints shall be spot examined for a minimum length of 6 in. The location shall be under the tank shell at the outer edge of the joint. 04 |

R.7.6.6 Twenty-five percent of the butt-welded compression bar radial joints shall be spot examined for a minimum length of 6 in. except as required by 5.26.4.3. 04 |

R.7.7 RADIOGRAPHIC INSPECTION OF BUTT-WELDS IN PIPING

R.7.7.1 Butt-welds in piping and in pipe fittings within the limitations of 1.3.2, including the annular space of double-wall tanks, shall be radiographically inspected in conformance with R.7.7.2 through R.7.7.5.

R.7.7.2 Longitudinal welded joints in piping that contains liquid shall be completely radiographed except for welds in manufactured pipe welded without filler metal, 12 in. or less in diameter, which is hydrostatically tested to ASTM requirements.

R.7.7.3 Longitudinal welded joints in piping that contains vapor shall be completely radiographed except for welds in manufactured pipe welded without filler metal, 18 in. or less in diameter, which is hydrostatically tested to ASTM requirements.

R.7.7.4 Ten percent of the circumferential welded joints in all piping shall be completely radiographed.

R.7.7.5 Butt-welded joints used to fabricate tank fittings shall be completely radiographed.

R.7.8 NONPRESSURE PARTS

Welds for pads, lifting lugs, and other nonpressure parts, as well as temporary lugs for alignment and scaffolding attached to primary components, shall be made in full compliance with a welding procedure qualified in accordance with R.6.1. Lugs attached for erection purposes shall be removed by the grinding of all remaining welds followed by magnetic-particle examination. Plate that is gouged or torn in removing the lugs shall be repaired using a qualified procedure, followed by grinding. Where such repairs are made in primary components, the area shall be inspected using the magnetic-particle method. A visual inspection is adequate for repaired areas in secondary components.

R.8 Testing the Tank in Contact With Liquid Contents

The provisions stated in this section are testing requirements for the tank refrigerated by the liquid contents. The provisions in R.9 cover the outer tank that is not in contact with the refrigerated liquid and is subjected to a higher temperature that approaches atmospheric.

R.8.1 GENERAL PROCEDURE

A thorough check for tightness and structural adequacy is essential for a single-wall tank or for an inner tank of a double-wall tank. Except as permitted by R.8.5, the test shall be conducted after the entire tank is complete, but before the insulation is applied. The hydrostatic test shall be performed by filling the tank with water to the design liquid level and applying an overload air pressure of 1.25 times the pressure for which the vapor space is designed. The hydrostatic test shall not produce a membrane tensile stress in any part of the tank exceeding 85% of the minimum specified yield strength or 55% of the minimum specified tensile strength of the material. 04 |

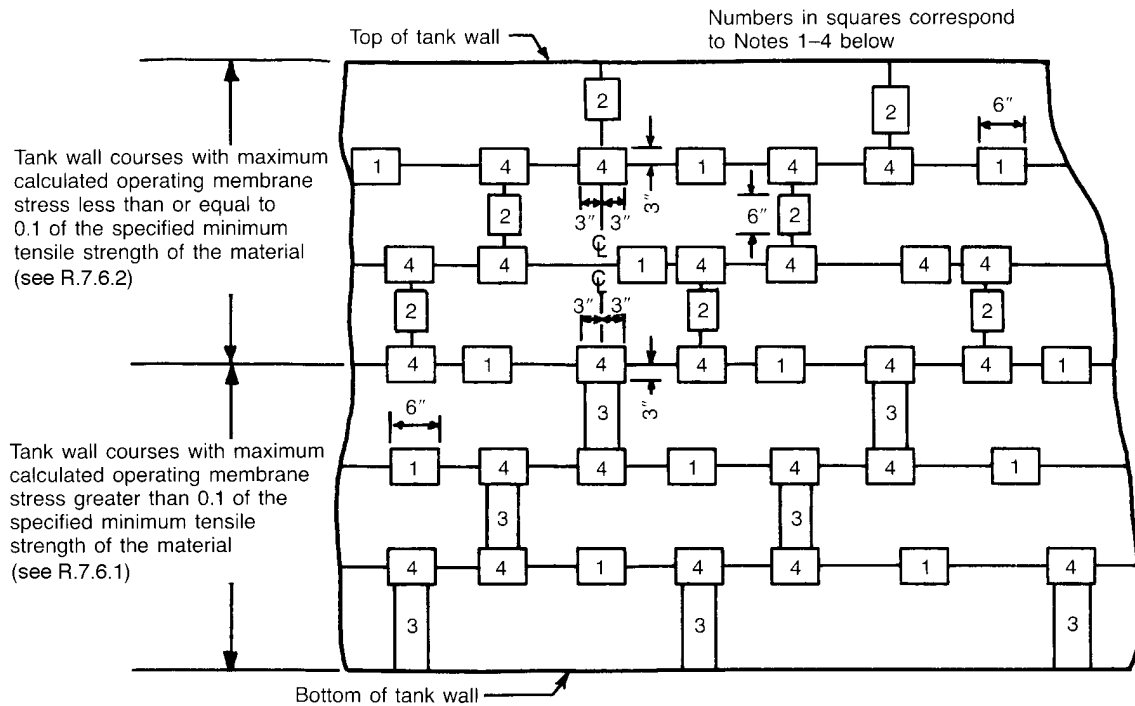

Notes:

1. One circumferential spot examination shall be performed in the first 10 feet for each welding operator of each type and thickness. After the first 10 feet, without regard to the number of welders, one circumferential spot examination shall be performed between each longitudinal joint on the course below.
2. One longitudinal spot examination shall be performed in the first 10 feet for each welder or welding operator of each type and thickness. After the first 10 feet, without regard to the number of welders, one longitudinal spot examination shall be performed in each longitudinal joint.
3. Longitudinal joints shall be 100-percent examined.
4. All intersections of joints shall be examined.

Figure R-2—Radiographic/Ultrasonic Examination Requirements for Butt-Welded Shell Joints in Cylindrical Flat-Bottom Tanks

04
04
04

R.8.2 TEST PRELIMINARIES

Before the tank is filled with water, the procedures described in R.8.2.1 through R.8.2.5 shall be completed.

R.8.2.1 All welded joints in the bottom of the tank shall be inspected by applying a solution film to the welds and pulling a partial vacuum of at least 3 lbf/in.² gauge above the welds by means of a vacuum box with a transparent top.

R.8.2.2 Complete penetration and complete fusion welds that join the cylindrical wall to the tank bottom shall be inspected by applying a solution film to the welds and pulling a partial vacuum of at least 3 lbf/in.² gauge above the welds by means of a vacuum box with a transparent top.

R.8.2.3 When the weld in R.8.2.2 does not have complete penetration and complete fusion, the initial weld passes, inside and outside of the shell, shall have all slag and non-metals removed from the surface of the welds and the welds

examined visually. After completion of the inside and outside fillet or partial penetration welds, the welds shall be tested by pressurizing the volume between the inside and outside welds with air pressure to 15 lbf/in.² gauge and applying a solution film to both welds. To assure that the air pressure reaches all parts of the welds, a sealed blockage in the annular passage between the inside and outside welds must be provided by welding at one or more points. Additionally, a small pipe coupling communicating with the volume between the welds must be welded on each side of and adjacent to the blockages. The air supply must be connected at one end and a pressure gauge connected to a coupling on the other end of the segment under test.

R.8.2.4 The attachment welding around all reinforced openings in the bottom, shell, and roof shall be inspected by applying air pressure of 15 lbf/in.² gauge behind the reinforcement plates and simultaneously applying a solution film to the welds. The test holes in the reinforcing plates shall be left open.

02

02

R.8.2.5 The attachment fillet welds around bottom openings, which do not permit the application of air pressure behind the reinforcing plate, shall be inspected by applying a solution film and by a vacuum box inspection.

R.8.3 HYDROSTATIC TEST

The provisions described in R.8.3.1 through R.8.3.5 shall apply during and after water filling for the hydrostatic test.

R.8.3.1 The tank shall be vented to the atmosphere when it is filled with or emptied of water.

R.8.3.2 During water filling, the elevations of at least four equidistant points at the bottom of the tank shell and on top of the ringwall or slab shall be checked. Differential settlement, or uniform settlement of substantial magnitude, requires an immediate stop to water filling. Any further filling with water will depend on an evaluation of the measured settlement.

R.8.3.3 The tank shall be filled with water to the design liquid level. In the case of settlement, as stated in R.8.3.2, an appropriate corrective action shall be taken before further filling or, alternatively the design liquid level shall be reduced to the actual maximum test water level.

R.8.3.4 After the tank is filled with water and before the pneumatic test pressure is applied, anchor bolts or anchor straps, if provided, shall be tightened against the hold-down brackets.

R.8.3.5 All welds in the shell, including the corner weld between the shell and the bottom, shall be visually checked for tightness.

R.8.4 PNEUMATIC PRESSURE

R.8.4.1 An air pressure equal to 1.25 times the pressure for which the vapor space is designed shall be applied to the enclosed space above the water level. In the case of a double-wall tank with an open-top inner tank, where the air pressure acts against the outer tank and the inner tank is thus not stressed by the air pressure, the inner tank may be emptied of water before the pneumatic pressure testing begins.

R.8.4.2 The test pressure shall be held for 1 hour.

R.8.4.3 The air pressure shall be reduced until the design pressure is reached.

R.8.4.4 Above the water level, all welded joints, welds around openings, and piping joints shall be checked with a solution film. A visual inspection may be substituted for the solution-film inspection of the welded joints if they have been previously checked with a vacuum box. Above the water level, the solution-film inspection shall be made of all welds around openings, all piping joints, and the compression-ring welds, including the attachment welds to the roof and shell.

R.8.4.5 The opening pressure or vacuum of the pressure relief and vacuum relief valves shall be checked by pumping air above the water level and releasing the pressure, then partially withdrawing water from the tank.

R.8.4.6 After the tank has been emptied of water and is at atmospheric pressure, the anchorage, if provided, shall be rechecked for tightness against the hold-down brackets.

R.8.4.7 Air pressure equal to the design pressure shall be applied to the empty tank, and the anchorage, if provided, and the foundation shall be checked for uplift.

R.8.5 TEMPORARY OPENINGS AFTER HYDROSTATIC TEST

When approved by the purchaser in writing, and only in the case of tanks which when complete have no shell penetrations, it is permitted to restore by welding up to four temporary shell openings after the hydrostatic test in accordance with the provisions of this section.

R.8.5.1 Each temporary opening shall be restored by the insertion of a shell plate that matches the thickness and specification of adjacent shell material, and is welded into place with full fusion butt-welds. The insert plate shall be round with diameter no less than 24 in. and no greater than 42 in.

R.8.5.2 The insert plate weld shall not cross any shell seams and shall be at least the greater of 10 times the shell thickness or 12 in. from any other weld in the shell including shell seams, shell-to-bottom weld or attachment welds.

R.8.5.3 The butt weld around the periphery of the plate shall be examined over 100% of its length by the magnetic particle method, by the radiographic method and by the ultrasonic method. Ultrasonic examination acceptance criteria shall be as given in Table U-1. The magnetic particle examination is required on the root pass, on the back-gouged surface, and on the inside and outside finished weld surfaces. Additionally, the weld shall be vacuum box leak tested.

R.9 Testing the Outer Tank of a Double-Wall Refrigerated Tank

The tightness test shall be made before insulation is installed.

R.9.1 TEST PROCEDURES

R.9.1.1 The inner tank shall be opened to the atmosphere, and a sufficient amount of water shall be added to the inner tank to balance the upward pressure against the inner tank bottom produced by the pneumatic test of the outer tank; as an alternative, the pressure between the inner and outer tanks can be equalized.

R.9.1.2 Air pressure shall be applied to the space enclosed by the outer tank equal to at least the design gas pressure but not exceeding a pressure that would overstress either the inner or outer tank.

R.9.1.3 While the test pressure is being held, all welded seams and connections in the outer shell and roof shall be thoroughly inspected with solution film unless they were previously checked with a vacuum box.

R.9.1.4 The air pressure shall be released.

R.9.1.5 Pressure relief and vacuum relief valves shall be checked by applying the design gas pressure to the outer tank, followed by evacuation of the outer space to the vacuum setting of the relief valve.

R.10 Foundations

R.10.1 GENERAL

R.10.1.1 Appendix C describes the factors involved in obtaining adequate foundations for tanks that operate at atmospheric temperature. The foundations for refrigerated tanks are more complicated because of the thermal movement of the tank, the insulation required for the bottom, the effects of foundation freezing and possible frost heaving, and the anchorage required to resist uplift.

R.10.1.2 The services of a qualified foundation engineer are essential. Experience with tanks in the area may provide sufficient data, but normally a thorough investigation, including soil tests, would be required for proper design of the foundation.

R.10.2 TYPES OF FOUNDATIONS

The nature of the soil, bearing capacity, and predicted settlement are factors that lead to a choice of foundations. At questionable sites where large settlements are anticipated, or where clay soils may be subjected to continual consolidation over long periods of time, a concrete slab supported by piling should be considered. Where anticipated settlements are acceptable and where the soil provides adequate bearing capacity, a ringwall-type foundation with compacted material within the ringwall is usually acceptable. A ringwall serves two purposes. It encloses the compacted material under the tank and provides a weight that, when anchor bolts are attached to the shell, resists any uplifting tendency of the shell under internal pressure and under wind or earthquake loads.

R.10.3 BEARING ON FOUNDATIONS

Foundations shall be designed to resist the load exerted by the tank and its contents when the tank is filled with water to the design liquid level. Foundations shall be designed for at least the maximum operating conditions including the wind or earthquake loads. Under water test, the total load on the foundation shall not exceed 125% of the allowable loading.

R.10.4 UPLIFTING FORCE AND DOWNWARD WEIGHTS

The uplifting force to be considered in designing the ringwall or concrete pad foundation may be offset by the coexistent downward weights and forces, including the metal and insulation weight of the shell and roof, and the concrete and earth weight transmitted by the anchorage to the shell. The tank shall be assumed to be empty of liquid.

R.10.5 UPLIFT ON FOUNDATION

R.10.5.1 The increased uplift described in R.10.5.2 and R.10.5.3 is intended to apply to the size of the ringwall and foundation but not to the anchorage.

R.10.5.2 For tanks with an internal design pressure less than 1 lbf/in.² gauge, the uplift shall be taken as the smaller of the maximum uplift values computed under the following conditions:

- The internal design pressure times 1.5 plus the design wind load on the shell and roof.
- The internal design pressure plus 0.25 lbf/in.² gauge plus the design wind load on the shell and roof.

R.10.5.3 For tanks with an internal design pressure of 1 lbf/in.² gauge and over, the uplift, if any, shall be calculated under the combined conditions of 1.25 times the internal design condition plus the design wind load on the shell and roof.

R.10.5.4 When the anchorage is designed to meet the requirements of R.3.6.4.2, the foundation should be designed to resist the uplift that results from three times the design pressure with the tank full to the design liquid level. When designing to any of the conditions of this paragraph, it is permissible to utilize friction between the soil and the vertical face of the ringwall and all of the effective liquid weight.

R.11 Marking

R.11.1 DATA ON NAMEPLATE

The data required to be marked on the tank by the manufacturer is listed in 8.1.

R.11.2 LOCATION OF NAMEPLATE

In addition to the requirements of 8.1, the nameplate shall be attached to the tank at an accessible location but shall be outside of any insulation or protective covering of the tank. The nameplate for the inner tank shall be located on the outer tank wall but shall refer to the inner tank. The nameplate, if any, for the outer tank of a double-wall tank shall be located adjacent to the nameplate for the inner tank and shall refer to the outer tank.

**For Committee
Use Only**

APPENDIX S—AUSTENITIC STAINLESS STEEL STORAGE TANKS

S.1 Scope

S.1.1 This appendix covers materials, design, fabrication, erection, and testing requirements for aboveground, welded, austenitic stainless steel storage tanks constructed of material grades 304, 304L, 316, 316L, 317, and 317L. This appendix does not cover stainless steel clad plate or strip lined construction.

S.1.2 This appendix applies only to tanks in non-refrigerated service. For stainless steel tanks in refrigerated service, refer to Appendix Q of this standard. Minimum design metal temperature of the non-refrigerated tanks in the scope of the appendix is not limited. Maximum design metal temperature shall be limited as given in 1.2.2. For the purposes of this appendix, the design temperature shall be the maximum operating temperature as specified by the purchaser. Ambient temperature tanks (non-heated) shall have a design temperature of 40°C (100°F). It is cautioned that exothermic reactions

occurring inside unheated storage tanks can produce temperatures exceeding 40°C (100°F).

S.1.3 This appendix is intended to provide the petroleum industry, chemical industry, and other users with tanks of safe design for containment of fluids within the design limits.

S.1.4 The minimum thicknesses in this appendix do not contain any allowance for corrosion.

S.1.5 This appendix states only the requirements that differ from the basic rules in this standard. For requirements not stated, the basic rules must be followed.

S.2 Materials

S.2.1 SELECTION AND ORDERING

S.2.1.1 Materials shall be in accordance with Table S-1.

Table S-1a—ASTM Materials for Stainless Steel Components (SI Units)

Plates and Structural Members (Note 1)	Piping and Tubing Seamless or Welded (Note 2)	Forgings (Notes 2, 3)	Bolting and Bars (Notes 4, 5)
A 240M, Type 304 A 240M, Type 304L A 240M, Type 316 A 240M, Type 316L A 240M, Type 317 A 240M, Type 317L	A 213M, Grade TP 304 A 213M, Grade TP 304L A 213M, Grade TP 316 A 213M, Grade TP 316L A 213M, Grade TP 317 A 213M, Grade TP 317L A 312M, Grade TP 304 A 312M, Grade TP 304L A 312M, Grade TP 316 A 312M, Grade TP 316L A 312M, Grade TP 317 A 312M, Grade TP 317L A 358M, Grade 304 A 358M, Grade 304L A 358M, Grade 316 A 358M, Grade 316L A 403M, Class WP 304 A 403M, Class WP 304L A 403M, Class WP 316 A 403M, Class WP 316L A 403M, Class WP 317 A 403M, Class WP 317L	A 182M, Grade F 304 A 182M, Grade F 304L A 182M, Grade F 316 A 182M, Grade F 316L A 182M, Grade F 317 A 182M, Grade F 317L	A 193M, Class 1, Grades B8, B8A, and B8M A 194M, Grades B8, B8A, B8M, and B8MA A 320M, Grades B8, B8A, B8M, and B8MA A 479M, Type 304 A 479M, Type 304L A 479M, Type 316 A 479M, Type 316L A 479M, Type 317

Notes:

1. Unless otherwise specified by the purchaser, plate, sheet, or strip shall be furnished with a No. 1 finish and shall be hot-rolled, annealed, and descaled.
2. Carbon steel flanges and/or stub ends may be used by agreement between the purchaser and manufacturer, providing the design and details consider the dissimilar properties of the materials used and are suitable for the intended service.
3. Castings shall not be used unless specified by the purchaser. If specified, castings shall meet ASTM A 351 and shall be inspected in accordance with ASME Section VIII, Division 1, Appendix 7.
4. All bars in contact with the product shall be furnished in the hot-rolled, annealed, and descaled condition.
5. Other bolting materials may be used by agreement between the purchaser and manufacturer.

Table S-1b—ASTM Materials for Stainless Steel Components (US Customary Units)

Plates and Structural Members (Note 1)	Piping and Tubing Seamless or Welded (Note 2)	Forgings (Notes 2, 3)	Bolting and Bars (Notes 4, 5)
A 240, Type 304 A 240, Type 304L A 240, Type 316 A 240, Type 316L A 240, Type 317 A 240, Type 317L	A 213, Grade TP 304 A 213, Grade TP 304L A 213, Grade TP 316 A 213, Grade TP 316L A 213, Grade TP 317 A 213, Grade TP 317L A 312, Grade TP 304 A 312, Grade TP 304L A 312, Grade TP 316 A 312, Grade TP 316L A 312, Grade TP 317 A 312, Grade TP 317L A 358, Grade 304 A 358, Grade 304L A 358, Grade 316 A 358, Grade 316L A 403, Class WP 304 A 403, Class WP 304L A 403, Class WP 316 A 403, Class WP 316L A 403, Class WP 317 A 403, Class WP 317L	A 182, Grade F 304 A 182, Grade F 304L A 182, Grade F 316 A 182, Grade F 316L A 182, Grade F 317 A 182, Grade F 317L	A 193, Class 1, Grades B8, B8A, and B8M A 194, Grades B8, B8A, B8M, and B8MA A 320, Grades B8, B8A, B8M, and B8MA A 479, Type 304 A 479, Type 304L A 479, Type 316 A 479, Type 316L A 479, Type 317

Notes:

1. Unless otherwise specified by the purchaser, plate, sheet, or strip shall be furnished with a No. 1 finish and shall be hot-rolled, annealed, and descaled.
2. Carbon steel flanges and/or stub ends may be used by agreement between the purchaser and manufacturer, providing the design and details consider the dissimilar properties of the materials used and are suitable for the intended service.
3. Castings shall not be used unless specified by the purchaser. If specified, castings shall meet ASTM A 351 and shall be inspected in accordance with ASME Section VIII, Division 1, Appendix 7.
4. All bars in contact with the product shall be furnished in the hot-rolled, annealed, and descaled condition.
5. Other bolting materials may be used by agreement between the purchaser and manufacturer.

S.2.1.2 Selection of the type/grade of stainless steel depends on the service and environment to which it will be exposed and the effects of fabrication processes. The purchaser shall select the type/grade.

S.2.1.3 External structural attachments may be carbon steels meeting the requirements of Section 2 of this standard, providing they are protected from corrosion and the design and details consider the dissimilar properties of the materials used. (This does not include shell, roof, or bottom openings and their reinforcement.) Carbon steel attachments (e.g., clips for scaffolding) shall not be welded directly to any internal surface of the tank.

S.2.2 PACKAGING

Packaging stainless steel for shipment is important to its corrosion resistance. Precautions to protect the surface of the material will depend on the surface finish supplied and may vary among manufacturers. Normal packaging methods may not be sufficient to protect the material from normal shipping damage. If the intended service requires special precautions, special instructions should be specified by the purchaser.

S.2.3 IMPACT TESTING

Impact tests are not required for austenitic stainless steel base metals.

S.3 Design

S.3.1 OPERATING TEMPERATURE

S.3.1.1 The purchaser shall specify the maximum operating temperature of the tank, not to exceed the maximum temperature of 120°C (250°F) given in 5.2.

S.3.2 MAXIMUM TENSILE STRESS

S.3.2.1 The maximum tensile stress shall be in accordance with 5.5.3 except Table S-2 shall be used to determine S_{TS} .

S.3.3 MAXIMUM COMPRESSIVE STRESS

S.3.3.1 Allowable compressive stresses shall be in accordance with 5.5.4, except the allowable compressive stress shall be reduced by the ratio material modulus of elasticity at the design temperature to 200,000 Mpa (29,000,000 lbf/in.²) for values $(t - c)/R$ less than 0.0175 and by the ratio of the

materials minimum yield strength at the design temperature to 205 Mpa (30,000 lbf/in.²) for values of $(t - c)/R$ equal to or greater than 0.0175.

S.3.4 MAXIMUM ALLOWABLE STRESS FOR STRUCTURAL MEMBERS AND BOLTS

S.3.4.1 The maximum allowable stress values for structural members shall be in accordance with Table 3-3 except the allowable stresses for compression shall be reduced by the ratio of the materials yield strength at design temperature to 205 Mpa (30,000 lbf/in.²).

S.3.5 FLAT BOTTOMS OF CYLINDRICAL TANKS

S.3.5.1 The minimum thickness for bottom plates shall be 5 mm (³/₁₆ in.), exclusive of any corrosion allowance specified by the purchaser.

S.3.6 INTERMEDIATE WIND GIRDERS FOR CYLINDRICAL SIDEWALLS

S.3.6.1 The value H1 in 5.10.6.1 shall be reduced by the ratio of the materials modulus of elasticity at the design temperature to 200,000 Mpa (29,000,000 lbf/in.²).

S.3.6.2 The value Wtr in 5.10.6.2 shall be reduced by the ratio of the materials modulus of elasticity at the design temperature to 200,000 Mpa (29,000,000 lbf/in.²).

S.3.7 COMPRESSION RINGS

S.3.7.1 The value of 15,000 in equation (27) in 5.12.4.3 shall be reduced by the ratio of the material yield strength at the design temperature to 205 Mpa (30,000 lbf/in.²).

S.3.8 FLAT COVER PLATES AND BLIND FLANGES

S.3.8.1 The value *s* in 5.21 shall be in accordance with Table S-3.

S.3.9 STRESS RELIEVING

S.3.9.1 The stress relieving requirements of 5.25 need not be performed unless specified by the purchaser.

S.3.10 FLUSH-TYPE SHELL CONNECTION

S.3.10.1 The value *t_b* in 5.27.4.5 shall be reduced by the ratio of the materials yield stress at the design temperature to 205 Mpa (30,000 lbf/in.²).

S.4 Fabrication

S.4.1 GENERAL

Special precautions must be observed to minimize the risk of damage to the corrosion resistance of stainless steel. Stainless steel shall be handled in a manner that minimizes contact with iron or other types of steel during all phases of fabrication and construction. The following sections describe the major precautions that should be observed during fabrication and handling.

S.4.2 STORAGE

Storage should be under cover and removed from shop dirt, fumes, and pickling operations. If outside storage is necessary, provisions should be made for rainwater to drain and allow the material to dry. Stainless steel should not be stored in contact with carbon steel. Materials containing chlorides, including foods, beverages, oils, and greases, should not come in contact with stainless steel.

Table S-2—Maximum Allowable Stress Values for Simple Tension

Material Type	Min Yield		Min Tensile		Allowable Stress for Design Temperature Not Exceeding (<i>S_{TS}</i>)					
					40°C	100°F	90°C	200°F	120°C	250°F
	Mpa	lbf/in. ²	Mpa	lbf/in. ²	Mpa	lbf/in. ²	Mpa	lbf/in. ²	Mpa	lbf/in. ²
304	205	30,000	515	75,000	155	22,500	129	18,750	122	17,800
304L	170	25,000	485	70,000	129	18,750	110	16,050	104	15,200
316	205	30,000	515	75,000	155	22,500	133	19,350	126	18,400
316L	170	25,000	485	70,000	129	18,750	109	15,825	103	15,000
317	205	30,000	515	75,000	155	22,500	134	19,425	127	18,500
317L	205	30,000	515	75,000	155	22,500	134	19,425	127	18,500

Notes:

1. *S_{TS}* may be interpolated between temperatures.
2. The design stress corresponds to the lesser of 0.33 of the minimum tensile strength or 0.75 of the minimum yield strength.
3. For dual certified materials (e.g., ASTM A182M/A 182 Type 304L/304), use the allowable stress of the grade specified by the purchaser.

Table S-3—Allowable Stresses for Plate Ring Flanges

Material Type	Allowable Stress for Design Temperatures Not Exceeding					
	40°C	100°F	90°C	200°F	120°C	250°F
	Mpa	lbf/in. ²	Mpa	lbf/in. ²	Mpa	lbf/in. ²
304	140	20,000	115	16,700	108	15,800
304L	117	16,700	99	14,300	93	13,500
316	140	20,000	119	17,200	112	16,300
316L	117	16,700	97	14,100	92	13,300
317	140	20,000	119	17,300	114	16,500
317L	140	20,000	119	17,300	114	16,500

Notes:

1. Allowable stresses may be interpolated between temperatures.
2. The allowable stresses are based on a lower level of permanent strain.
3. The design stress shall be the lesser of 0.3 of the minimum tensile strength, or ²/₃ of the minimum yield strength.
4. For dual certified materials (e.g. ASTM A182M/A 182 Type 304L/304), use the allowable stress of the grade specified by the purchaser.

Table S-4—Yield Strength Values

Material Type	Yield Strength for Design Temperature Not Exceeding					
	40°C	100°F	90°C	200°F	120°C	250°F
	Mpa	lbf/in. ²	Mpa	lbf/in. ²	Mpa	lbf/in. ²
304	205	30,000	170	25,000	163	23,700
304L	170	25,000	148	21,400	140	20,300
316	205	30,000	178	25,800	170	24,500
316L	170	25,000	145	21,100	138	20,000
317	205	30,000	179	25,900	170	24,700
317L	205	30,000	179	25,900	170	24,700

Table S-5—Modulus of Elasticity at the Design Temperature

Modulus of Elasticity for Design Temperature Not Exceeding			
°C	°F	Mpa	lbf/in. ²
40	100	193,000	28,000,000
90	200	189,000	27,400,000
120	250	186,000	27,000,000

S.4.3 THERMAL CUTTING

S.4.3.1 Thermal cutting of stainless steel shall be by the iron powder burning carbon arc or the plasma-arc method.

S.4.3.2 Thermal cutting of stainless steel may leave a heat-affected zone and intergranular carbide precipitates. This heat-affected zone may have reduced corrosion resistance unless removed by machining, grinding, or solution annealing and quenching. The purchaser shall specify if the heat-affected zone is to be removed.

S.4.4 FORMING

S.4.4.1 Stainless steels shall be formed by a cold, warm, or hot forming procedure that is non-injurious to the material.

S.4.4.2 Stainless steels may be cold formed, providing the maximum strain produced by such forming does not exceed 10% and control of forming spring-back is provided in the forming procedure.

S.4.4.3 Warm forming at 540°C (1000°F) to 650°C (1200°F) may cause intergranular carbide precipitation in 304, 316, and 317 grades of stainless steel. Unless stainless steel in this sensitized condition is acceptable for the service of the equipment, it will be necessary to use 304L, 316L, or 317L grades or to solution anneal and quench after forming. Warm forming shall be performed only with agreement of the purchaser.

S.4.4.4 Hot forming, if required, may be performed within a temperature range of 900°C (1650°F) to 1200°C (2200°F).

S.4.4.5 Forming at temperatures between 650°C (1200°F) and 900°C (1650°F) is not permitted.

S.4.5 CLEANING

S.4.5.1 When the purchaser requires cleaning to remove surface contaminants that may impair the normal corrosion resistance, it shall be done in accordance with ASTM A 380, unless otherwise specified. Any additional cleanliness

requirements for the intended service shall be specified by the purchaser.

S.4.5.2 When welding is completed, flux residues and weld spatter shall be removed mechanically using stainless steel tools.

S.4.5.3 Removal of excess weld metal, if required, shall be done with a grinding wheel or belt that has not been previously used on other metals.

S.4.5.4 Chemical cleaners used shall not have a detrimental effect on the stainless steel and welded joints and shall be disposed of in accordance with laws and regulations governing the disposal of such chemicals. The use of chemical cleaners shall always be followed by thorough rinsing with water and drying (see S.4.9).

S.4.6 BLAST CLEANING

If blast cleaning is necessary, it shall be done with sharp acicular grains of sand or grit containing not more than 2% by weight iron as free iron or iron oxide. Steel shot or sand used previously to clean nonstainless steel is not permitted.

S.4.7 PICKLING

If pickling of a sensitized stainless steel is necessary, an acid mixture of nitric and hydrofluoric acids shall not be used. After pickling, the stainless steel shall be thoroughly rinsed with water and dried.

S.4.8 PASSIVATION OR IRON FREEING

When passivation or iron freeing is specified by the purchaser, it may be achieved by treatment with nitric or citric acid. The use of hydrofluoric acid mixtures for passivation purposes is prohibited for sensitized stainless.

S.4.9 RINSING

S.4.9.1 When cleaning and pickling or passivation is required, these operations shall be followed immediately by rinsing, not allowing the surfaces to dry between operations.

S.4.9.2 Rinse water shall be potable and shall not contain more than 200 parts per million chloride at temperatures below 40°C (100°F), or no more than 100 parts per million chloride at temperatures above 40°C (100°F) and below 65°C (150°F), unless specified otherwise by the purchaser.

S.4.9.3 Following final rinsing, the material shall be completely dried.

S.4.10 WELDING

S.4.10.1 Tanks and their structural attachments shall be welded by any of the processes permitted in 6.6.2 or by the plasma arc process. Galvanized components or components

painted with zinc-rich paint shall not be welded directly to stainless steel.

S.4.10.2 Filler metal chemistry shall match the type of base metals joined. Dissimilar welds to carbon steels shall use filler metals of E309 or higher alloy content.

S.4.11 WELDING PROCEDURE AND WELDER QUALIFICATIONS

Impact tests are not required for austenitic stainless steel weld metal and heat-affected zones.

S.4.12 POSTWELD HEAT TREATMENT

Postweld heat treatment of austenitic stainless steel materials need not be performed unless specified by the purchaser.

S.5 Inspection and Testing

S.5.1 WELD INSPECTION

Where specified, the magnetic-particle method of examination shall be replaced by the liquid-penetrant examination method.

S.5.2 HYDROSTATIC TEST CONSIDERATIONS—QUALITY OF TEST WATER

S.5.2.1 The materials used in the construction of stainless steel tanks may be subject to severe pitting, cracking, or rusting if they are exposed to contaminated test water for extended periods of time. The purchaser shall specify a minimum quality of test water that conforms to the following requirements:

- Unless otherwise specified by the purchaser, water used for hydrostatic testing of tanks shall be potable and treated, containing at least 0.2 parts per million free chlorine.
- Water shall be substantially clean and clear.
- Water shall have no objectionable odor (that is, no hydrogen sulfide).
- Water pH shall be between 6 and 8.3.
- Water temperature shall be below 50°C (120°F).
- The chloride content of the water shall be below 50 parts per million, unless specified otherwise by the purchaser.

S.5.2.2 When testing with potable water, the exposure time shall not exceed 21 days, unless specified otherwise by the purchaser.

S.5.2.3 When testing with other fresh waters, the exposure time shall not exceed seven days.

S.5.2.4 Upon completion of hydrostatic test, water shall be completely drained. Wetted surfaces shall be washed with potable water when non-potable water is used for the test and completely dried. Particular attention shall be given to low spots, crevices, and similar areas. Hot air drying is not permitted.

S.6 Marking

S.6.1 Brazing shall be deleted from 6.1.3

S.7 Appendices

The appendices are applicable for use with austenitic stainless steels as follows:

- a. Appendix D is applicable; however see S.2.1.3 for special requirements when attaching to carbon steel supports.
- b. Appendix E is applicable; however see S.2.13 for special requirements when attaching external carbon steel supports.

Internal supports shall meet the material requirements of Appendix S.

- c. Appendix H is not applicable; stress relieving is only required when specified by the purchaser and must be performed with care and in such a manner that does not damage or alter the properties of the stainless steel.
- d. Appendix Q is not applicable.
- e. Appendix R is not applicable.
- f. All other appendices are applicable without modifications.

04

04

For Committee Use Only

APPENDIX U—ULTRASONIC EXAMINATION IN LIEU OF RADIOGRAPHY

U.1 Purpose and Scope

This appendix provides detailed rules for the use of the ultrasonic examination (UT) method for the examination of tank seams as permitted by 3.26, R.7.6, and Q.7.6. This alternative is limited to joints where the thickness of the thinner of the two members joined is greater than or equal to 10 mm ($\frac{3}{8}$ in.).

U.2 Definitions

U.2.1 documenting: Preparation of text and/or and figures.

U.2.2 evaluation: All activities required in U.6.3 through U.6.6 to determine the acceptability of a flaw.

U.2.3 flaw: A reflector that is not geometric or metallurgical in origin that may be detectable by nondestructive testing but is not necessarily rejectable.

U.2.4 flaw categorization: Whether a flaw is a surface flaw or is a subsurface flaw (see U.6.4). Note that a flaw need not be surface breaking to be categorized as a surface flaw.

U.2.5 flaw characterization: The process of quantifying the size, location, and shape of a flaw. See U.6.3 for size and location. The only shape characterization required by this appendix is applied to the results of supplemental surface examination by MT or PT (see U.6.6.2).

U.2.6 indication: That which marks or denotes the presence of a reflector.

U.2.7 interpretation: The determination of whether an indication is relevant or nonrelevant, i.e., whether it originates from a geometric or metallurgical feature or conversely originates from a flaw (see U.6.2).

U.2.8 investigation: Activities required to determine the interpretation of an indication (see U.6.1 and U.6.2).

U.2.9 recording: The writing of ultrasonic data onto an appropriate electronic medium.

U.2.10 reflector: An interface at which an ultrasonic beam encounters a change in acoustic impedance and at which at least part of the energy is reflected.

U.3 Technique

U.3.1 The ultrasonic examination volume shall include the weld metal, plus the lesser of 25 mm (1 in.) or t of adjoining base metal on each side of the weld unless otherwise agreed upon by the purchaser and the manufacturer.

U.3.2 Ultrasonic examination for the detection of flaws shall be performed using automated, computer-based data acquisition except that scanning of adjacent base metal for flaws that can interfere with the examination may be performed manually. Ultrasonic examination for sizing of flaws shall be performed as described in U.6.3.1.

U.3.3 A documented examination strategy or scan plan shall be provided showing transducer placement, movement, and component coverage that provides a standardized and repeatable methodology for weld acceptance. The scan plan shall also include ultrasonic beam angle to be used, beam directions with respect to weld centerline, and tank material volume examined for each weld. The documentation shall be made available to the Owner upon request.

U.3.4 Data from the examination volume, per U.3.1, shall be recorded and/or documented as follows:

a. For automated computer-based scans, data shall be recorded using the same system essential variables, specified value or range of values, used for the demonstration of the procedure per U.4.3 below.

b. For manual scans, results shall be documented in a written report.

U.3.5 The ultrasonic examination shall be performed in accordance with a written procedure which has been reviewed and approved by the purchaser and conforms to the requirements of Section V, Article 4, except that:

a. The calibration block shown in Fig. T-434.2.1 of Section V, Article 4 shall be used, and;

b. For examination techniques that provide plate quality information (e.g., time of flight diffraction), the initial base material straight-beam examination need not be performed.

U.3.6 The examination methodology (including U.6.6) shall be demonstrated to be effective over the full weld volume. It is recognized that time of flight diffraction (TOFD) may have limitations in detection of flaws at the surface such that it may be necessary to supplement TOFD with pulse-echo techniques suitable for the detection of near-field and far-field flaws. The variety of surface and sub-surface category flaws in the test plate mandated by U.4.3.a are intended to ensure that any such limitations are adequately addressed.

U.3.7 It is recognized that in the ultrasonic inspection of joints with austenitic weld metals, initial screening for defects may be done by methods that determine flaw lengths but give only limited information on flaw height. In these cases a length and upper bound height acceptance criteria is applied (see Table U-2).

U.4 Personnel Qualifications and Training

U.4.1 PERSONNEL QUALIFICATIONS

Personnel performing and evaluating UT examinations shall be qualified and certified in accordance with their employer's written practice. ASNT SNT-TC-IA or CP-189 shall be used as a guideline. Only Level II or III personnel shall perform UT examinations, analyze the data, or interpret the results.

U.4.2 QUALIFICATION RECORDS

Qualification records of certified personnel shall be approved by the manufacturer and maintained by their employer.

U.4.3 PERSONNEL TESTING

Personnel who acquire and analyze UT data shall be trained using the equipment of U.3.2, and the procedure of U.3.5 above. Additionally, they shall pass a practical examination based on the technique on a blind test plate. The testing program details shall be by agreement between the purchaser and the inspection company, but shall in any case include the following elements as a minimum:

- a. The test plate shall contain a variety of surface and sub-surface category flaws including multiple flaws described in section U.6.5. Some of the flaws shall be acceptable and others unacceptable per the applicable criteria of Table U-1 or U-2.
- b. The practical examination should cover detection, interpretation, sizing, plotting, categorization, grouping, and characterization that is sufficient to cover the cases outlined in U.6.
- c. Criteria for passing the test shall include limits on the number of miscalls, both of rejectable flaws, missed or accepted, and acceptable regions rejected.
- d. Testing shall be facilitated by a third-party or by the purchaser.

U.5 Level III Review

U.5.1 The final data package shall be reviewed by a UT Level III individual qualified in accordance with U.4.1 and U.4.3 above. The review shall include:

- a. The ultrasonic data record.
- b. Data interpretations.
- c. Evaluations of indications performed by another qualified Level II or III individual. The data review may be performed by another individual from the same organization.

U.5.2 Alternatively, the review may be achieved by arranging for a data acquisition and initial interpretation by a Level

II individual qualified in accordance with U.4.1 and U.4.3 above, and a final interpretation and evaluation shall be performed by a Level III individual qualified per U.5.1.

U.6 Interpretation and Evaluation

U.6.1 INVESTIGATION CRITERIA

Reflectors that produce a response greater than 20% of the reference level shall be investigated. Alternatively, for methods or techniques that do not use amplitude recording levels, sized reflectors longer than 40% of the acceptable surface or subsurface flaws in Table U-1 or U-2 as applicable shall be investigated. The investigation shall interpret whether the indication originates from a flaw or is a geometric indication in accordance with U.6.2 below. When the reflector is determined to be a flaw, the flaw shall be evaluated and acceptance criteria of Table U-1 or U-2 as applicable shall apply.

U.6.2 INTERPRETATION AS GEOMETRIC/ METALLURGICAL

Ultrasonic indications of geometric and metallurgical origin shall be interpreted as described in U.6.2.1, U.6.2.2, and U.6.2.3.

U.6.2.1 Indications that are determined to originate from the surface configurations (such as weld reinforcement or root geometry) or variations in metallurgical structure of materials may be interpreted as geometric indications, and:

- a. Need not be sized or categorized in accordance with U.6.3 and U.6.4;
- b. Need not be compared to the allowable flaw acceptance criteria of Table U-1 or U-2;
- c. The maximum indication amplitude (if applicable) and location shall be documented, for example: internal attachments, 200% DAC maximum amplitude, 25 mm (1 in.) above the weld centerline, on the inside surface, from 90 to 95 degrees.

U.6.2.2 The following steps shall be taken to classify an indication as geometric:

- a. Interpret the area containing the indication in accordance with the applicable examination procedure;
- b. Plot and verify the indication's coordinates; provide a cross-sectional display showing the indication's position and any surface conditions such as root or counterbore; and
- c. Review fabrication or weld prep drawings.

U.6.2.3 Alternatively, other NDE methods or techniques may be applied to interpret an indication as geometric (e.g., alternative UT beam angles, radiography, ID and/or OD profiling).

U.6.3 FLAW SIZING

U.6.3.1 Flaws shall be sized using automated, computer-based data acquisition or by a supplemental manual technique that has been demonstrated to perform acceptably per U.4.3.

U.6.3.2 The dimensions of the flaw shall be defined by the rectangle that fully contains the area of the flaw. The length (*l*) of the flaw shall be drawn parallel to the inside pressure-retaining surface of the component. The height (*h*) of the flaw shall be drawn normal to the inside pressure retaining surface.

U.6.4 FLAW CATEGORIZATION

If the space between the surface and the flaw in the thru-thickness direction is less than one-half the measured height of the flaw, then the flaw shall be categorized as a surface flaw with flaw height extending to the surface of the material.

U.6.5 GROUPING OF MULTIPLE FLAWS

U.6.5.1 Discontinuous flaws that are oriented primarily in parallel planes shall be considered to lie in a single plane if the distance between the adjacent planes is equal to or less than 13 mm (1/2 in.).

U.6.5.2 If the space between two flaws, aligned along the axis of weld, is less than two times the length of the longer of the two, the two flaws shall be considered a singular flaw.

U.6.5.3 If the space between two flaws aligned in the through-thickness direction is less than the height of the flaw of greater height, the two flaws shall be considered a singular flaw.

U.6.6 FLAW ACCEPTANCE CRITERIA

U.6.6.1 Acceptance Criteria Tables

Flaw dimensions resulting after the application of the rules of U.6.3, U.6.4 and U.6.5 shall be evaluated for acceptance using the applicable criteria of Table U-1 or U-2.

U.6.6.2 Surface Examination

Flaws characterized as surface flaws during the UT examination may or may not be surface connected. Therefore, unless the UT data analysis confirms that the flaw is not surface connected, a supplemental surface examination (MT or PT) shall be performed in accordance with 5.15.2 or 5.15.4 as applicable for all surface flaws. Any flaws detected by MT or PT, and characterized as planar, are unacceptable, regardless of length.

U.7 Repairs

All repaired areas, plus the lesser of 25 mm (1 in.) or *t* of the adjoining weld on each side of the repair, shall be reinspected per this Appendix.

U.8 Flaw Documentation

In addition to the data record prescribed by U.3.4, written documentation shall be produced for each unacceptable flaw and those acceptable flaws that either exceed 50% of reference level for amplitude based techniques or exceed 75% of the acceptable length for non-amplitude techniques.

Table U-1—Flaw Acceptance Criteria for UT Indications (May be Used for All Materials)

Thickness at Weld (<i>t</i>) ^a mm (in.)	Acceptable Flaw Lengths, (<i>l</i>) mm (in.)							
	For Surface Flaw ^b with Height, (<i>h</i>) mm (in.)			For Sub-surface Flaw with Height, (<i>h</i>) mm (in.)				
	2 (0.08)	2.5 (0.10)	3 (0.12)	2 (0.08)	3 (0.12)	4 (0.16)	5 (0.2)	6 (0.24)
10 (0.375) to < 13 (0.50)	8 (0.30)	8 (0.30)	4 (0.15)	14 (0.55)	5 (0.20)	4 (0.15)	Not allowed	Not allowed
13 (0.50) to < 19 (0.75)	8 (0.30)	8 (0.30)	4 (0.15)	38 (1.50)	8 (0.30)	5 (0.20)	4 (0.15)	3 (0.10)
19 (0.75) to < 25 (1.0)	8 (0.30)	8 (0.30)	4 (0.15)	75 (3.00)	13 (0.50)	8 (0.30)	6 (0.25)	5 (0.20)
25 (1.0) to < 32 (1.25)	9 (0.35)	8 (0.30)	4 (0.15)	100 (4.00)	20 (0.80)	9 (0.35)	8 (0.30)	6 (0.25)
32 (1.25) to < 38 (1.50)	9 (0.35)	8 (0.30)	4 (0.15)	125 (5.00)	30 (1.20)	10 (0.40)	8 (0.30)	8 (0.30)
38 (1.50) to < 44 (1.75)	9 (0.35)	8 (0.30)	4 (0.15)	150 (6.00)	38 (1.50)	10 (0.40)	9 (0.35)	8 (0.30)

Notes:

^a*t* = thickness of the weld excluding any allowable reinforcement. For a butt weld joining members having different thickness at the weld, *t* is the thinner of the two.

^bAny surface flaw, to be deemed acceptable, must satisfy both the size limitations of this table and additionally satisfy the MT/PT characterization limitations of U.6.6.2

04

04

Table U-2—Alternate Flaw Acceptance Criteria for UT Indications^a

(Applicable to 3XX stainless steel and aluminum with toughness meeting Appendix Q, and to 9% nickel steel with Table U-3 Toughness.)

	Thickness at weld ^b (<i>t</i>) mm (in.)	Limit on flaw length (<i>l</i>) mm (in.)	Limit on surfaced flaw height ^c (<i>h</i>) mm (in.)	Limit on sub-surface flaw height (<i>h</i>) mm (in.)
Based on Length and Upper Bound Height	All <i>t</i>	12.0 (0.45)	50% of <i>t</i>	50% of <i>t</i>
Based on Flaw Length and Sized Height	All <i>t</i>	18.0 (0.70)	Smaller of 6.5 (0.25) or 25% of <i>t</i>	Smaller of 9.0 (0.35) or 50% of <i>t</i>

Notes:

^aIn order to use this acceptance criteria for 9% nickel steel, it is required that the Charpy V-notch impact results for base metal (transverse) as required in Q.2.2.2, and for weld metal and heat affected zones as required in Q.6.2.5 and Q.6.6.5 conform to the higher energy levels given in Table U-3 in lieu of Table Q-2.

^b*t* = thickness of the weld excluding any allowable reinforcement. For a butt weld joining two members having different thickness at the weld, *t* is the thinner of these two thicknesses.

^cAny surface flaw, to be deemed acceptable, must satisfy both the size limitations of this table and additionally satisfy the MT/PT characterization limitations of U.6.6.2.

^dWhen Table U.2 is applicable, any flaw is acceptable if it satisfies either of the two lines of Table U-2.

Table U-3—Charpy V-notch Impact Values Required to Use Table U-2 for 9% Nickel Steel

Size of Specimen (mm)	Transverse	
	Value Required for Acceptance ^a J (ft-lbs)	Minimum Value without Requiring Retest ^b J (ft-lbs)
10 × 10.00	50 (37)	40 (30)
10 × 7.50	38 (28)	30 (22)

Notes:

^aAverage of three specimens.

^bOnly one specimen of a set.

2002 Publications Order Form

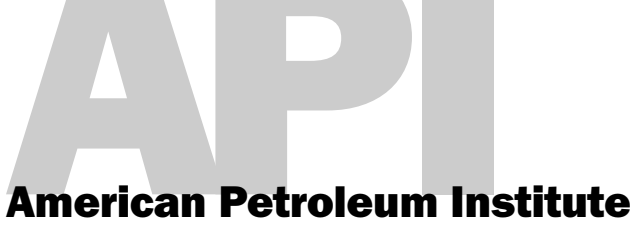

Available through Global Engineering Documents.

Effective January 1, 2002.

Phone Orders: 1-800-854-7179 (Toll-free in the U.S. and Canada)

303-397-7956 (Local and International)

Fax Orders: 303-397-2740

Online Orders: www.global.ihs.com

Date: _____

API Member (Check if Yes)

Invoice To (Check here if same as "Ship To")

Name: _____
 Title: _____
 Company: _____
 Department: _____
 Address: _____

 City: _____ State/Province: _____
 Zip/Postal Code: _____ Country: _____
 Telephone: _____
 Fax: _____
 E-Mail: _____

Ship To (UPS will not deliver to a P.O. Box)

Name: _____
 Title: _____
 Company: _____
 Department: _____
 Address: _____

 City: _____ State/Province: _____
 Zip/Postal Code: _____ Country: _____
 Telephone: _____
 Fax: _____
 E-Mail: _____

Quantity	Product Number	Title	SO★	Unit Price	Total
	C51008	API 510, Pressure Vessel Inspection Code: Maintenance Inspection, Rating, Repair, and Alteration		\$ 94.00	
	C52024	RP 520, Sizing, Selection, and Installation of Pressure-Relieving Devices in Refineries, Part II—Installation		\$ 61.00	
	C57002	API 570, Piping Inspection Code: Inspection, Repair, Alteration, and Rerating of In-Service Piping Systems		\$ 83.00	
	C57501	RP 575, Inspection of Atmospheric & Low Pressure Storage Tanks		\$ 83.00	
	C65010	Std 650, Welded Steel Tanks for Oil Storage		\$ 248.00	
	C65302	Std 653, Tank Inspection, Repair, Alteration, and Reconstruction		\$ 138.00	
	C20005	Std 2000, Venting Atmospheric and Low-Pressure Storage Tanks: Nonrefrigerated and Refrigerated		\$ 83.00	
	A26101	Std 2610, Design, Construction, Operation, Maintenance & Inspection of Terminal and Tank Facilities		\$ 83.00	

Payment Enclosed **P.O. No.** (Enclose Copy) _____

Charge My Global Account No. _____

VISA **MasterCard** **American Express** **Diners Club** **Discover**

Credit Card No.: _____

Print Name (As It Appears on Card): _____

Expiration Date: _____

Signature: _____

Subtotal
Applicable Sales Tax (see below)
Rush Shipping Fee (see below)
Shipping and Handling (see below)
Total (in U.S. Dollars)

★ To be placed on Standing Order for future editions of this publication, place a check mark in the SO column and sign here:

Pricing and availability subject to change without notice.

Mail Orders – Payment by check or money order in U.S. dollars is required except for established accounts. State and local taxes, \$10 processing fee*, and 5% shipping must be added. Send mail orders to: **API Publications, Global Engineering Documents, 15 Inverness Way East, M/S C303B, Englewood, CO 80112-5776, USA.**

Purchase Orders – Purchase orders are accepted from established accounts. Invoice will include actual freight cost, a \$10 processing fee*, plus state and local taxes.

Telephone Orders – If ordering by telephone, a \$10 processing fee* and actual freight costs will be added to the order.

Sales Tax – All U.S. purchases must include applicable state and local sales tax. Customers claiming tax-exempt status must provide Global with a copy of their exemption certificate.

Shipping (U.S. Orders) – Orders shipped within the U.S. are sent via traceable means. Most orders are shipped the same day. Subscription updates are sent by First-Class Mail. Other options, including next-day service, air service, and fax transmission are available at additional cost. Call 1-800-854-7179 for more information.

Shipping (International Orders) – Standard international shipping is by air express courier service. Subscription updates are sent by World Mail. Normal delivery is 3-4 days from shipping date.

Rush Shipping Fee – Next Day Delivery orders charge is \$20 in addition to the carrier charges. Next Day Delivery orders must be placed by 2:00 p.m. MST to ensure overnight delivery.

Returns – All returns must be pre-approved by calling Global's Customer Service Department at 1-800-624-3974 for information and assistance. There may be a 15% restocking fee. Special order items, electronic documents, and age-dated materials are non-returnable.

***Minimum Order** – There is a \$50 minimum for all orders containing hardcopy documents. The \$50 minimum applies to the order subtotal including the \$10 processing fee, excluding any applicable taxes and freight charges. If the total cost of the documents on the order plus the \$10 processing fee is less than \$50, the processing fee will be increased to bring the order amount up to the \$50 minimum. This processing fee will be applied before any applicable deposit account, quantity or member discounts have been applied. There is no minimum for orders containing only electronically delivered documents.

There's more where this came from.

The American Petroleum Institute provides additional resources and programs to the oil and natural gas industry which are based on API® Standards. For more information, contact:

- API Monogram® Licensing Program Phone: 202-962-4791
Fax: 202-682-8070
- American Petroleum Institute Quality Registrar (APIQR®) Phone: 202-962-4791
Fax: 202-682-8070
- API Spec Q1® Registration Phone: 202-962-4791
Fax: 202-682-8070
- API Perforator Design Registration Phone: 202-962-4791
Fax: 202-682-8070
- API Training Provider Certification Program Phone: 202-682-8490
Fax: 202-682-8070
- Individual Certification Programs Phone: 202-682-8064
Fax: 202-682-8348
- Engine Oil Licensing and Certification System (EOLCS) Phone: 202-682-8516
Fax: 202-962-4739
- API PetroTEAM™ (Training, Education and Meetings) Phone: 202-682-8195
Fax: 202-682-8222

Check out the API Publications, Programs, and Services Catalog online at www.api.org.



Helping You Get The Job Done Right.®

**For Committee
Use Only**

For Committee
Use Only

Additional copies are available through Global Engineering Documents at (800) 854-7179 or (303) 397-7956

Information about API Publications, Programs and Services is available on the World Wide Web at: <http://www.api.org>



**American
Petroleum
Institute**

1220 L Street, Northwest
Washington, D.C. 20005-4070
202-682-8000

Product No. C62010